



# Hypro Series 1502, 1700, 4001, 4101, 6500, 7560 and 7700 Roller Pumps

**HYPRO®**

Form L-1572  
Rev. A

## Original Instruction Manual

KEEP FOR FUTURE REFERENCE

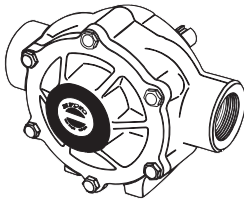

**Series 1502  
6-Roller Pump**

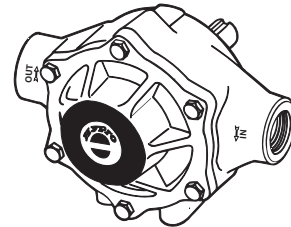

**Series 1700  
5-Roller Pump**

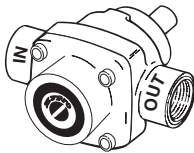

**Series 4001 & 4101  
4-Roller Pump**

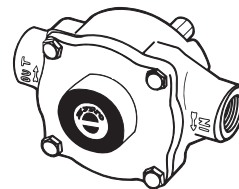

**Series 6500  
6-Roller Pump**

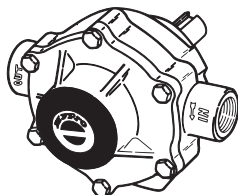

**Series 7560  
8-Roller Pump**

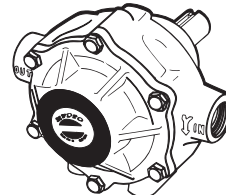

**Series 7700  
7-Roller Pump**

### **Pentair**

375 5th Ave., New Brighton, MN 55112

Phone: (651)766-6300 -OR- 800-424-9776 Fax: 800-323-6496

[www.hypropumps.com](http://www.hypropumps.com)

EU Authorized Representative:

EC	REP
----	-----

 QNET BV Hommerterweg 286  
6436 AM Amstenrade, The Netherlands  
KvK Zuid-Limburg 14091511

---

# Contents

---

EU Language .....	3
Introduction.....	3
Description.....	4
Intended Use(s).....	4
Purpose of Manual.....	4
Misuses.....	5
Pump Identification.....	5
Pump Technical Data.....	6
1502 Series.....	6
1700 Series.....	7
4001 Series.....	8-9
4101 Series.....	10-12
6500 Series.....	13
7560 Series.....	14-16
7700 Series.....	17
Fluid Pumping Applications.....	18
Tools.....	18
Lifting, Transport, and Intermediate Storage.....	18-19
Assembly and Installation.....	19
Assembly.....	19
Installation.....	20-23
Control System(s).....	23
Commissioning, Start-Up, Operation, Shutdown.....	23
Information.....	23
Start-Up, Operation, Shutdown.....	24-25
Pumps Equipped with Only DC Motor.....	25
Pumps Equipped with Hydraulic Motor.....	24
PTO/Belt Drive/Flexible Coupling.....	25
Maintenance and Servicing.....	25
Information.....	26
Disposal.....	26
Cleaning.....	26
Maintenance, Routine Servicing, and Inspection.....	26
Troubleshooting.....	26-35
Replacement Parts.....	31
Series 4001 and 4101 Electric Motor-Driven Pumps.....	36
Declaration of Incorporation.....	39
Warranty.....	back cover

---

# EU Languages

---

DO NOT attempt to install or operate your pump before reading the manual. Original copies of the manual for Hypro pumps are provided in English. To find a copy in your native language, go to [www.hypropumps.com](http://www.hypropumps.com).

Vor dem Ablesen des Handbuches versuchen Sie NICHT, Ihre Pumpe zu installieren. Originale des Handbuches für Hypro-Pumpen werden auf englisch zur Verfügung gestellt. Zu eine Kopie in Ihrer Muttersprache finden, zu [www.hypropumps.com](http://www.hypropumps.com) zu gehen (German)

N'essayez pas d'installer votre pompe avant de lire le manuel. Des exemplaires originaux du manuel pour des pompes de Hypro sont fournis en anglais. Pour trouver une copie dans votre langue maternelle pour aller a [www.hypropumps.com](http://www.hypropumps.com) (French)

NON tentare di installare la vostra pompa prima di leggere il manuale. Esempio originale del manuale per Hypro pompe sono in inglese. Per trovare una copia nella vostra lingua andare a [www.hypropumps.com](http://www.hypropumps.com) (Italian)

Не пытайтесь установить ваш насос до чтения руководства. Оригинальные копии этого руководства для насосы Hypro на английском языке. Найти копию на ваш родной язык перейти к [www.hypropumps.com](http://www.hypropumps.com) (Russian)

NO intente instalar su bomba antes de leer el manual. Copias originales del manual para Hypro se provee de bombas en ingles. Para encontrar una copia en tu idioma nativo ir a [www.hypropumps.com](http://www.hypropumps.com) (Spanish)

NIE próbować instalować pompy przed jej odczytaniem instrukcji. Oryginalne kopie instrukcji obsługi pomp Hypro są dostarczane w języku angielskim. Aby uzyskać kopię w twoim ojczystym języku przejdź do [www.hypropumps.com](http://www.hypropumps.com) (Polish)

Takmaya çalışmayın okumadan önce pompanın manuel. Orijinal kopyalarını Hypro pompaları için İngilizce olarak sunulmuştur. Bir kopyasını bulmak için yerel dil git [www.hypropumps.com](http://www.hypropumps.com) (Turkish)

Nao tente instalar a bomba antes de ler o manual. As copias originais dos manuais para Hypro bombas sao fornecidos em Ingles. Para encontrar uma copia em sua lingua nativa ir para [www.hypropumps.com](http://www.hypropumps.com) (Portuguese)

VERGEET NIET uw pomp voor het lezen van het handboek. Exemplaren van de handleiding voor Hypro pompen zijn beschikbaar in het Engels. Op zoek naar een exemplaar in uw eigen taal ga naar [www.hypropumps.com](http://www.hypropumps.com) (Dutch)

---

# Introduction

---

## Description

Hypro centrifugal pumps are designed for creating and boosting pressure in fluid circuits. The pump operates by taking in fluid from the inlet port after which it is slung by the impeller and expelled through the outlet port. Construction features include housings, impellers and seals which come in a variety of materials in order to be resistant to a range of chemicals. Standard models of centrifugal pumps rotate clockwise, when looking at the front of the pump.

## Intended Uses

Hypro centrifugal pumps are intended for creating or boosting dynamic pressure in approved fluids. Hypro centrifugal pumps should never be used to pump liquids above 140°F (60°C), or below 34°F (1°C). For pumps equipped with hydraulic motors, the pump should not be run if the hydraulic oil temperature exceeds 135°F (57°C). Any uses outside of those specified in this manual are considered misuses and are prohibited. Contact Hypro technical service with any questions regarding specific acceptable uses.

## Purpose of Manual

This manual provides instructions and requirements that must be met when installing, using and maintaining the product(s) identified on the cover.

If the product is sold, the seller must pass this manual onto the new owner.

The following special attention notices are used to notify and advise the user of this product of procedures that may be dangerous to the user or result in damage to the product.

### ATTENTION

Attention is used to notify of installation, operation, or maintenance information that is important but not safety related.



This symbol is used to denote the presence of an electrical hazard that will result in personal injury, death or property damage.



This symbol is used to denote the presence of a hazard that will result in personal injury, death or property damage.

**California Proposition 65 Warning** -- This product and related accessories contain chemicals known to the State of California to cause cancer, birth defects or other reproductive harm.

## Misuses

Hypro centrifugal pumps are designed to operate effectively within the specified speed, pressure and environmental ranges. Going outside of these ranges will void the warranty and could cause damage to property, serious injury, or death.

- **DO NOT** run the pump faster than the maximum specified speed.
- **DO NOT** run the pump higher than the maximum specified pressure.
- **DO NOT** run pumps when the liquid has exceeded the maximum or minimum temperature limit (see Intended Uses).
- **DO NOT** pump non-approved liquids.
- **DO NOT** pump water or other liquids for human consumption.
- **DO NOT** operate any Hypro pump under the influence of drugs or alcohol.
- **DO NOT** run the pump dry.
- **DO NOT** run the pump hydraulic motor higher than the specified RPM, pressure or flow.

## Pump Identification

Hypro uses serialized labeling to enable users to precisely identify the pump's manufacturing date.

**Serial Number:**

**First and second digits:** year (14 = 2014)

**Third through fifth digits:** consecutive day of the year the pump was manufactured.

**Sixth through tenth digits:** unique pump serial number.

## Pump Technical Data

(All specifications and performance data are based on water as a carrier fluid.)

### 1502 Series Pump Only

Pump Dimensions		
Dim.	Inch	mm
A	8.75	222
B	4.38	111
C	3.66	93
D	6.86	174
E	7.78	198
F	4.78	121
G	2.75	70
H	1.38	35
I	2.16	55
J	3.59	91
K	2.13	54

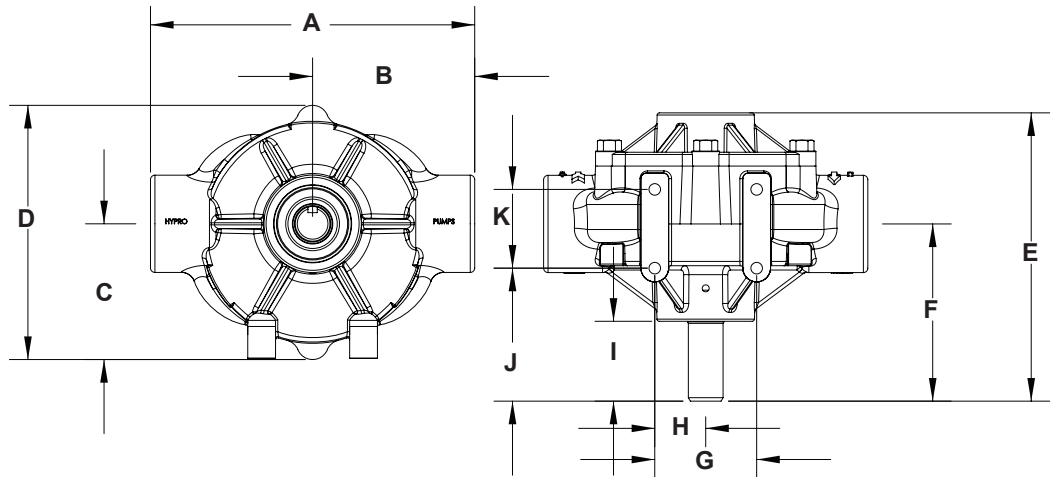

1502C, 1502N, 1502XL Pump Specifications										
Rollers:	Max. Flow Rate (GPM [LPM]):	Max. Pressure (PSI [BAR]):	Max RPM	Ports:	Shaft:	Continuous Operation (PSI [BAR]):	Intermittent Operation (PSI [BAR]):	Dry Weight (LBS [KG]):	Minimum Horsepower requirement	Mounting bolts
6	62.1 [235.1]	150 [10.3]	1000	1-1/2" NPT Outlet & Inlet	15/16" Dia. (Solid)	100 [6.9]	150 [10.3]	30 [13.6]	7.12	4 X 3/8-16 UNC

Performance Data 1502C, 1502N, 1502XL (Imperial)						
Pressure	GPM	HP	GPM	HP	GPM	HP
	@540 RPM		@600RPM		@1000RPM	
0 PSI	33.1	0.5	36.8	0.7	62.1	2.0
25 PSI	29.7	1.0	33.6	1.2	58.5	3.0
50 PSI	27.8	1.5	31.7	1.7	56.9	3.7
100 PSI	24.3	2.5	28.3	2.8	53.9	5.3
150 PSI	21.0	3.5	25.0	4.0	50.9	7.1

v						
Pressure	GPM	HP	GPM	HP	GPM	HP
	@540 RPM		@600RPM		@1000RPM	
0 PSI	33.1	0.5	36.8	0.7	62.1	2.0
25 PSI	29.7	1.0	33.6	1.2	58.5	3.0
50 PSI	27.8	1.5	31.7	1.7	56.9	3.7
100 PSI	24.3	2.5	28.3	2.8	53.9	5.3
150 PSI	21.0	3.5	25.0	4.0	50.9	7.1

# Pump Technical Data

## 1700 Series Pump Only

Pump Dimensions		
Dim.	Inch	mm
A	8.38	213
B	4.19	106
C	3.38	86
D	5.83	148
E	7.78	198
F	4.84	123
G	2.12	54
H	1.06	27
I	2.16	55
J	4.47	114

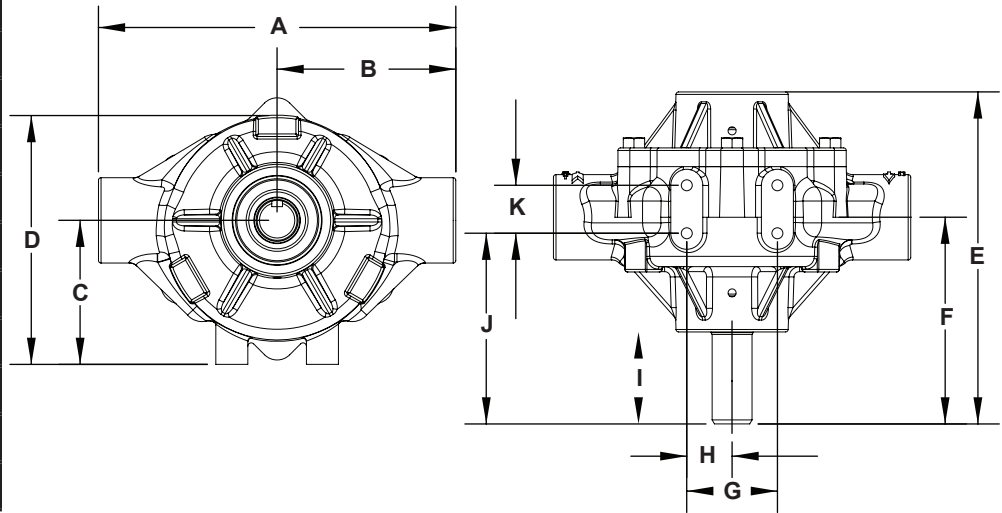

1700C, 1700N, 1700XL Pump Specifications										
Rollers:	Max. Flow Rate (GPM [LPM]):	Max. Pressure (PSI [BAR]):	Max RPM	Ports:	Shaft:	Continuous Operation (PSI [BAR]):	Intermittent Operation (PSI [BAR]):	Dry Weight (LBS [KG]):	Minimum Horsepower requirement	Mounting bolts
5	45.0 [170.3]	200 [13.8]	1000	1" NPT Inlet & Outlet 1-1/4" Hose Barb included	15/16" Dia. (Solid)	100 [6.9]	200 [13.8]	19 [8.6]	6.07	4 X 5/16- 18 UNC

Performance Data 1700 Series (Imperial)						
Pressure	GPM	HP	GPM	HP	GPM	HP
	@540 RPM		@600RPM		@1000RPM	
0 PSI	25.0	0.3	28.0	0.3	45.0	1.4
50 PSI	21.0	1.2	24.5	1.4	43.0	3.0
100 PSI	19.0	2.1	22.0	2.4	41.0	4.7
150 PSI	17.0	2.9	20.0	3.3	39.0	6.1
200 PSI	15.0	3.9	18.0	4.4	---	---

Performance Data 1700 Series (Metric)						
Pressure	LPM	HP	LPM	HP	LPM	HP
	@540 RPM		@600RPM		@1000RPM	
0 BAR	94.6	0.3	106.0	0.3	170.3	1.4
3.4 BAR	79.5	1.2	92.7	1.4	162.8	3.0
6.9 BAR	71.9	2.1	83.3	2.4	155.2	4.7
10.3 BAR	64.4	2.9	75.7	3.3	147.6	6.1
13.8 BAR	56.8	3.9	68.1	4.4	---	---

# Pump Technical Data

## 4001 Series Pump Only

Pump Dimensions		
Dim.	Inch	mm
A	4.75	121
B	2.38	61
C	1.67	42
D	3.03	77
E	5.39	137
F	3.34	85
G	1	25
H	0.49	13
I	1.43	36
J	2.96	75

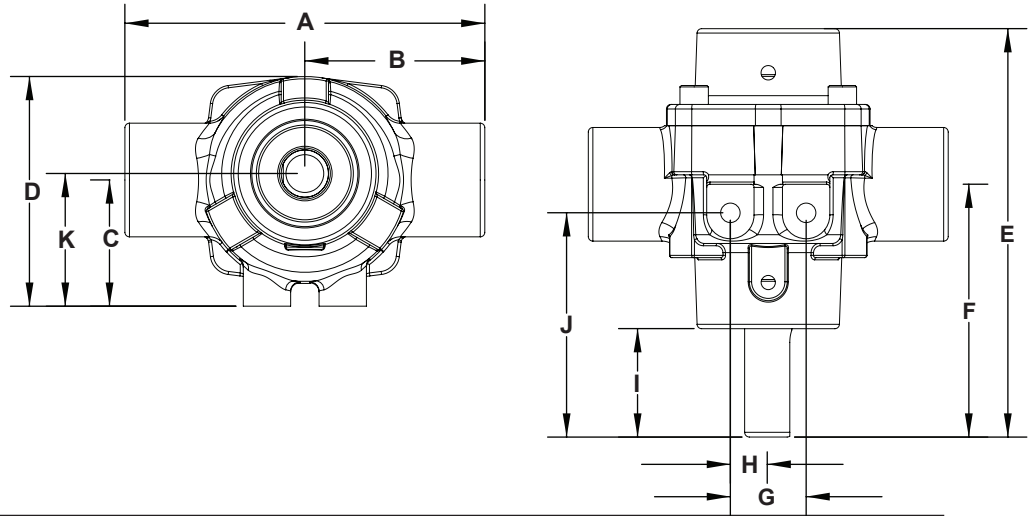

1502C, 1502N, 1502XL Pump Specifications										
Rollers:	Max. Flow Rate (GPM [LPM]):	Max. Pressure (PSI [BAR]):	Max RPM	Ports:	Shaft:	Continuous Operation (PSI [BAR]):	Intermittent Operation (PSI [BAR]):	Dry Weight (LBS [KG])	Minimum Horsepower requirement	Mounting bolts
6	62.1 [235.1]	150 [10.3]	1000	1-1/2" NPT Outlet & Inlet	15/16" Dia. (Solid)	100 [6.9]	150 [10.3]	30 [13.6]	7.12	4 X 3/8-16 UNC

Performance Data 4001C, 4001N, 4001X (Imperial)						
Pressure	GPM	HP	GPM	HP	GPM	HP
	@1100 RPM		@1400RPM		@1800RPM	
0 PSI	5.5	0.1	7.1	0.1	9.1	0.1
25 PSI	4.9	0.1	6.4	0.2	8.5	0.3
50 PSI	4.4	0.2	5.9	0.3	8.0	0.5
75 PSI	4.1	0.3	5.6	0.4	7.6	0.6
100 PSI	3.8	0.4	5.3	0.6	7.3	0.8
125 PSI	3.5	0.5	5.0	0.7	7.0	1.0
150 PSI	3.3	0.6	4.8	0.8	6.7	1.1

Performance Data 4001C, 4001N, 4001XL (Metric)						
Pressure	LPM	HP	LPM	HP	LPM	HP
	@1100 RPM		@1400RPM		@1800RPM	
0 BAR	20.8	0.1	26.9	0.1	34.4	0.1
1.7 BAR	18.5	0.1	24.2	0.2	32.2	0.3
3.4 BAR	16.6	0.2	22.3	0.3	30.3	0.5
5.2 BAR	15.5	0.3	21.2	0.4	28.7	0.6
6.9 BAR	14.4	0.4	20.1	0.6	27.6	0.8
8.6 BAR	13.2	0.5	18.9	0.7	26.5	1.0
10.3 BAR	12.5	0.6	18.2	0.8	25.4	1.1



# Pump Technical Data

## Motorized

Pump Dimensions		
Dim.	Inch	mm
A	5.12	130
B	2.56	65
C	2.54	64
D	5.17[5.15]	131[130]
E	3.8	97
F	13.24[11.91]	336[302]
G	4.45	113
H	8.79[7.45]	223[189]
I	1.5	38
J	2	51
K	2.63	67

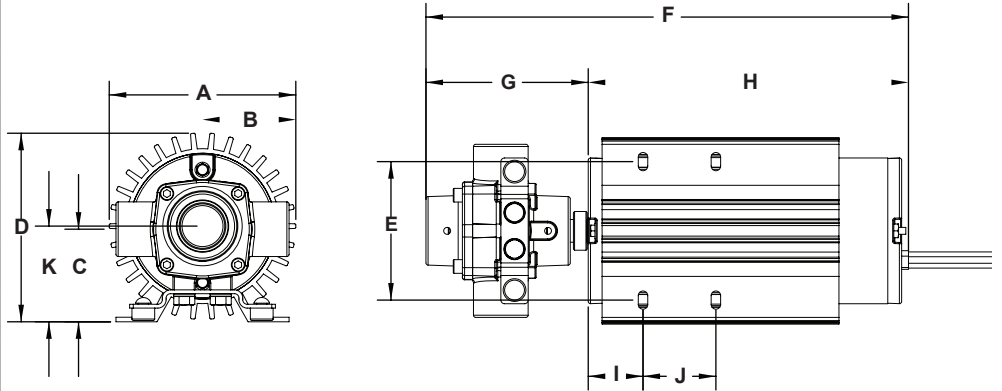

4001N-EH, 4001XL-EH, 4001N-E2H, 4001XL-E2H												
Pump	Rollers:	Max. Flow Rate (GPM [LPM]):	Max. Pressure (PSI [BAR]):	Max RPM	Voltage	Ports:	Shaft:	Continuous Operation (PSI [BAR]):	Intermittent Operation (PSI [BAR]):	Dry Weight (LBS [KG])	Minimum Horsepower Requirement	Mounting bolts
4001N-EH	4	10.4 [39.4]	35 [2.4]	1900	12-13.5VDC	¾" NPT Inlet & Outlet	½" Dia. (Hollow)	25 [1.7]	35 [2.4]	16-18 [7.3-8.2]	N/A	4 X 1/4-20 UNC
4001XL-EH								50 [3.5]	60 [4.1]			
4001N-E2H		9.8 [37.2]	60 [4.1]	1600				50 [3.5]	60 [4.1]			
4001XL-E2H								50 [3.5]	60 [4.1]			

Model 4001N-EH & 4001XL-EH (Imperial)							
Volts	PSI	GPM	AMPS	Volts	PSI	GPM	AMPS
12.0 (Battery) Engine off	0	9.4	14.8	13.5 (Alternator) Engine Running	0	10.4	17.1
	5	9.0	16.4		5	10.3	17.5
	10	8.6	18.0		10	9.9	19.0
	15	8.1	20.1		15	9.4	21.5
	20	7.5	23.1		20	8.9	23.8
	25	6.9	25.3		v25	8.4	26.8
	30	6.1	28.5*		30	7.8	29.6*
	35	5.8	30.3*		---	---	---

Model 4001N-EH & 4001XL-EH (Metric)							
Volts	BAR	LPM	AMPS	Volts	BAR	LPM	AMPS
12.0 (Battery) Engine off	0	35.6	14.8	13.5 (Alternator) Engine Running	0	39.4	17.1
	0.3	34.1	16.4		0.3	39.0	17.5
	0.7	32.6	18.0		0.7	37.5	19.0
	1.0	30.7	20.1		1.0	35.6	21.5
	1.4	28.4	23.1		1.4	33.7	23.8
	1.7	26.1	25.3		1.7	31.8	26.8
	2.1	23.1	28.5*		2.1	29.5	29.6*
	2.4	22.0	30.3*		---	---	---

Model 4001N-EH & 4001XL-EH (Imperial)							
Volts	PSI	GPM	AMPS	Volts	PSI	GPM	AMPS
12.0 (Battery) Engine off	0	9.4	14.8	13.5 (Alternator) Engine Running	0	10.4	17.1
	5	9.0	16.4		5	10.3	17.5
	10	8.6	18.0		10	9.9	19.0
	15	8.1	20.1		15	9.4	21.5
	20	7.5	23.1		20	8.9	23.8
	25	6.9	25.3		v25	8.4	26.8
	30	6.1	28.5*		30	7.8	29.6*
	35	5.8	30.3*		---	---	---

Model 4001N-EH & 4001XL-EH (Metric)							
Volts	BAR	LPM	AMPS	Volts	BAR	LPM	AMPS
12.0 (Battery) Engine off	0	35.6	14.8	13.5 (Alternator) Engine Running	0	39.4	17.1
	0.3	34.1	16.4		0.3	39.0	17.5
	0.7	32.6	18.0		0.7	37.5	19.0
	1.0	30.7	20.1		1.0	35.6	21.5
	1.4	28.4	23.1		1.4	33.7	23.8
	1.7	26.1	25.3		1.7	31.8	26.8
	2.1	23.1	28.5*		2.1	29.5	29.6*
	2.4	22.0	30.3*		---	---	---

# Pump Technical Data

## 4101 Series Pump Only

Pump Dimensions		
Dim.	Inch	mm
A	4.75	121
B	2.38	61
C	1.67	42
D	3.03	77
E	5.39	137
F	3.34	85
G	1	25
H	0.49	13
I	1.43	36
J	2.96	75
K	1.75	45

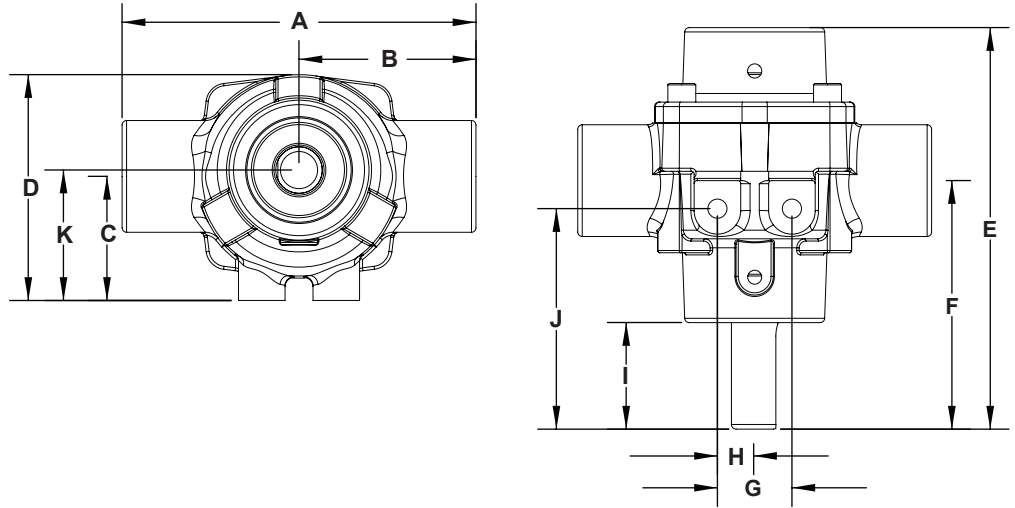

4101C, 4101N, 4101XL Pump Specifications										
Rollers:	Max. Flow Rate (GPM [LPM]):	Max. Pressure (PSI [BAR]):	Max RPM	Ports:	Shaft:	Continuous Operation (PSI [BAR]):	Intermittent Operation (PSI [BAR]):	Dry Weight (LBS [KG])	Minimum Horsepower requirement	Mounting bolts
4	7.2 [27.3]	150 [10.3]	2600	3/4" NPT Inlet & Outlet	5/8" Dia. (Solid) or 1/2" Dia. (Hollow)	100 [6.9]	150 [10.3]	5 [2.27]	1.08	2 X 5/16-18 UNC

Performance Data 4101C, 4101N, 4101XL (Imperial)						
Pressure	GPM	HP	GPM	HP	GPM	HP
	@1800 RPM		@2200RPM		@2600RPM	
0 PSI	5.0	0.1	6.2	0.1	7.2	0.2
25 PSI	4.8	0.2	5.8	0.3	6.9	0.3
50 PSI	4.5	0.3	5.6	0.4	6.6	0.5
75 PSI	4.2	0.5	5.4	0.6	6.4	0.6
100 PSI	3.9	0.6	5.0	0.7	6.0	0.8
125 PSI	3.7	0.7	4.7	0.8	5.7	0.9
150 PSI	3.4	0.8	4.4	1.0	5.4	1.1

Performance Data 4101C, 4101N, 4101XL (Metric)						
Pressure	LPM	HP	LPM	HP	LPM	HP
	@1800 RPM		@2200RPM		@2600RPM	
0 BAR	18.9	0.1	23.5	0.1	27.3	0.2
1.7 BAR	18.2	0.2	22.0	0.3	26.1	0.3
3.4 BAR	17.0	0.3	21.2	0.4	25.0	0.5
5.2 BAR	15.9	0.5	20.4	0.6	24.2	0.6
6.9 BAR	14.8	0.6	18.9	0.7	22.7	0.8
8.6 BAR	14.0	0.7	17.8	0.8	21.6	0.9
10.3 BAR	12.9	0.8	16.7	1.0	20.4	1.1

# Pump Technical Data

## Motorized

Pump Dimensions		
Dim.	Inch	mm
A	5.12	130
B	2.56	65
C	2.54	64
D	5.17[5.15]	131[130]
E	3.8	97
F	13.24[11.91]	336[302]
G	4.45	113
H	8.79[7.45]	223[189]
I	1.5	38
J	2	51
K	2.63	67

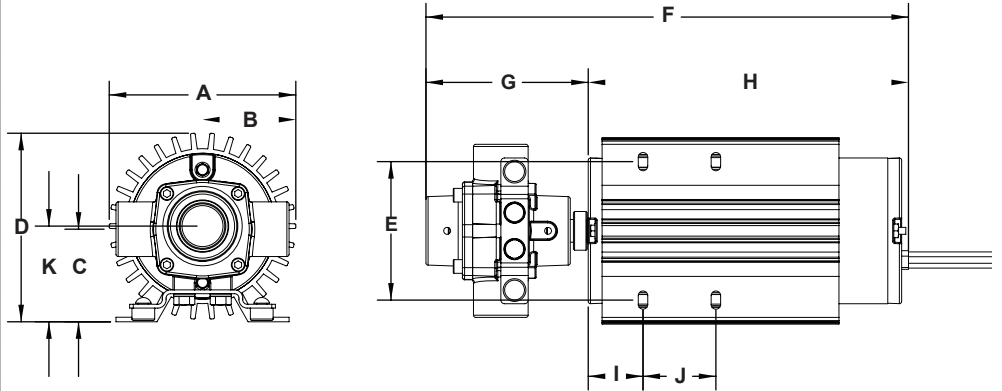

4101N-EH, 4101XL-EH, 4101N-E2H, 4101XL-E2H												
Pump	Rollers:	Max. Flow Rate (GPM [LPM]):	Voltage	Max. Pressure (PSI [BAR]):	Max RPM	Ports:	Shaft:	Continuous Operation (PSI [BAR]):	Intermittent Operation (PSI [BAR]):	Dry Weight (LBS [KG]):	Minimum Horsepower requirement	Mounting bolts
4101N-EH	4	6.6 [25.0]	12-13.5VDC	50 [3.4]	1900	¼" NPT Inlet & Outlet	½" Dia. (Hollow)	50 [3.4]	---	16-18 [7.3-8.2]	N/A	4 X 1/4-20 UNC
4101XL-EH												
4101N-E2H		5.7 [21.6]	100 [6.9]	1600				80 [5.5]				
4101XL-E2H												

Model 4101N-EH & 4101XL-EH							
Volts	PSI	GPM	AMPS	Volts	PSI	GPM	AMPS
12.0 (Battery) Engine off	0	5.7	9.8	13.5 (Alternator) Engine Running	0	6.6	11.1
	5	5.5	11.3		5	6.3	12.1
	10	5.1	12.3		10	6.0	13.3
	15	4.8	13.6		15	5.6	14.6
	20	4.5	15.1		20	5.3	16.0
	25	4.2	16.7		25	5.1	17.4
	30	4.0	18.5		30	4.9	19.2
	35	3.7	20.3		35	4.6	21.1
	40	3.4	21.5		40	4.4	22.9
	45	3.2	23.5		45	4.2	24.3
50	2.8	24.8	50	3.9	25.8		

Model 4101N-EH & 4101XL-EH							
Volts	BAR	LPM	AMPS	Volts	BAR	LPM	AMPS
12.0 (Battery) Engine off	0	21.6	9.8	13.5 (Alternator) Engine Running	0	25.0	11.1
	0.3	20.8	11.3		0.3	23.8	12.1
	0.7	19.3	12.3		0.7	22.7	13.3
	1.0	18.2	13.6		1.0	21.2	14.6
	1.4	17.0	15.1		1.4	20.1	16.0
	1.7	15.9	16.7		1.7	19.3	17.4
	2.1	15.1	18.5		2.1	18.5	19.2
	2.4	14.0	20.3		2.4	17.4	21.1
	2.8	12.9	21.5		2.8	16.7	22.9
	3.1	12.1	23.5		3.1	15.9	24.3
	3.4	10.6	24.8		3.4	14.8	25.8

Model 4101N-E2H & 4101XL-E2H (Imperial)							
Volts	PSI	GPM	AMPS	Volts	PSI	GPM	AMPS
12.0 (Battery) Engine off	0	5.3	9.2	13.5 (Alternator) Engine Running	0	5.7	9.8
	10	4.5	10.4		10	5.3	11.7
	20	4.0	13.5		20	4.8	13.8
	30	3.6	15.8		30	4.5	17.0
	40	3.2	19.8		40	4.0	19.8
	50	2.8	23.4		50	3.7	23.0
	60	2.3	26.7		60	3.3	26.0
	70	1.9	30.2		70	3.0	28.3
	80	1.4	31.8		80	2.7	31.3
	90	0.9	37.0**		90	2.2	34.6
100	0.5	38.8**	100	1.8	38.3**		

Model 4101N-E2H & 4101XL-E2H (Metric)							
Volts	BAR	LPM	AMPS	Volts	BAR	LPM	AMPS
12.0 (Battery) Engine off	0	20.1	9.2	13.5 (Alternator) Engine Running	0	21.6	9.8
	0.7	17.0	10.4		0.7	20.1	11.7
	1.4	15.1	13.5		1.4	18.2	13.8
	2.0	13.6	15.8		2.0	17.0	17.0
	2.8	12.1	19.8		2.8	15.1	19.8
	3.5	10.6	23.4		3.5	14.0	23.0
	4.1	8.7	26.7		4.1	12.5	26.0
	4.8	7.2	30.2		4.8	11.4	28.3
	5.5	5.3	31.8		5.5	10.2	31.3
	6.2	3.4	37.0**		6.2	8.3	34.6
	6.9	1.9	38.8**		6.9	6.8	38.3**

\*denotes a duty cycle of 66 (40 minutes on, 20 minutes off)  
 \*\*denotes a duty cycle of 50 (30 minutes on, 30 minutes off)

# Pump Technical Data

## Gas Engine

4101C-25, 4101XL-25 Pump Specifications										
Rollers:	Max. Flow Rate (GPM [LPM]):	Max. Pressure (PSI [BAR]):	Max RPM	Ports:	Shaft:	Continuous Operation (PSI [BAR]):	Intermittent Operation (PSI [BAR]):	Dry Weight (LBS [KG])	Engine	Mounting bolts
4	8.9 [33.7]	150 [10.3]	2600	¾" NPT Inlet & Outlet	5/8" Dia. (Solid)	100 [6.9]	150 [BAR]	29 [13.1]	2.5 HP	See engine manual

4101 Gas Engine Performance (Imperial)	
PSI	GPM
0 PSI	8.9
50 PSI	8.6
100 PSI	8.3
150 PSI	8.0

4101 Gas Engine Performance (Metric)	
BAR	LPM
0 BAR	33.7
3.4 BAR	32.6
6.9 BAR	31.4
10.3 BAR	30.3

# Pump Technical Data

## 6500 Series Pump Only

Pump Dimensions		
Dim.	Inch	mm
A	6.13	156
B	3.07	78
C	2.22	56
D	4.09	104
E	5.41	137
F	3.27	83
G	2.12	54
H	1.06	27
I	1.37	35
J	3.87	98

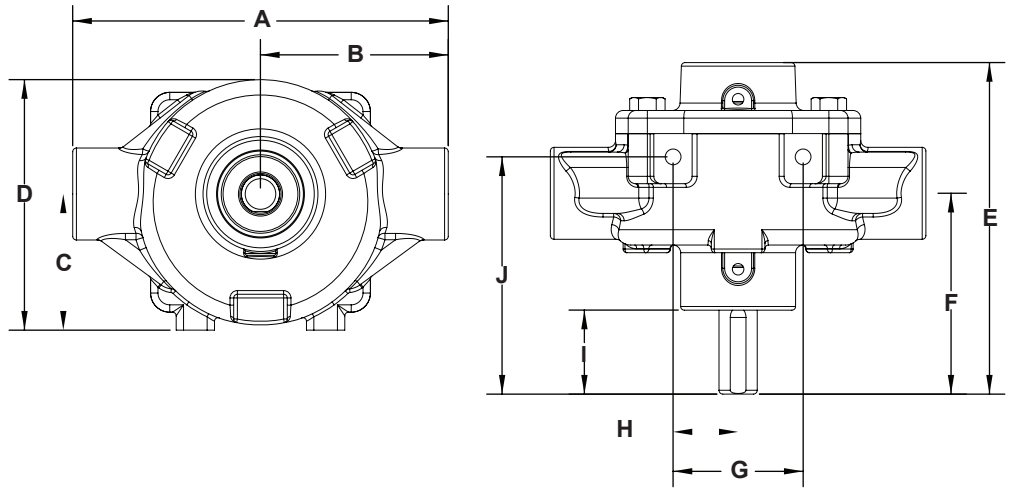

6500C, 6500N, 6500XL Pump Specifications										
Rollers:	Max. Flow Rate (GPM [LPM]):	Max. Pressure (PSI [BAR]):	Max RPM	Ports:	Shaft:	Continuous Operation (PSI [BAR]):	Intermittent Operation (PSI [BAR]):	Dry Weight (LBS [KG]):	Minimum Horsepower requirement	Mounting bolts
6	21.8 [82.5]	300 [20.7]	1200	-3/4" NPT Inlet & Outlet -1" Hose Barb included	5/8" Dia. (Solid)	100 [6.9]	300 [20.7]	9 [4.1]	4.17	2 X 5/16-18 UNC

Performance Data 6500C, 6500N, 6500XL (Imperial)						
Pressure	GPM	HP	GPM	HP	GPM	HP
	@540 RPM		@1000RPM		@1200RPM	
0 PSI	9.7	0.1	18.2	0.2	21.8	0.3
50 PSI	8.0	0.4	16.5	0.7	20.1	0.9
100 PSI	7.2	0.7	15.4	1.3	19.1	1.5
150 PSI	6.6	1.0	14.7	1.8	18.2	2.1
200 PSI	5.6	1.3	14.0	2.3	17.3	2.8
250PSI	4.9	1.7	13.4	2.9	16.5	3.5
300PSI	4.3	1.9	12.7	3.5	15.7	4.2

Performance Data 6500C, 6500N, 6500XL (Metric)						
Pressure	LPM	HP	LPM	HP	LPM	HP
	@540 RPM		@1000RPM		@1200RPM	
0 BAR	36.7	0.1	68.9	0.2	82.5	0.3
3.4 BAR	30.3	0.4	62.5	0.7	76.1	0.9
6.9 BAR	27.3	0.7	58.3	1.3	72.3	1.5
10.3 BAR	25.0	1.0	55.6	1.8	68.9	2.1
13.8 BAR	21.2	1.3	53.0	2.3	65.5	2.8
17.2 BAR	18.5	1.7	50.7	2.9	62.5	3.5
20.7 BAR	16.3	1.9	48.1	3.5	59.4	4.2

# Pump Technical Data

## 7560 Series Pump Only

Pump Dimensions		
Dim.	Inch	mm
A	7	178
B	3.5	89
C	2.88	73
D	5.45	138
E	6.91	176
F	4.37	111
G	2.12	54
H	1.06	27
I	1.97	50
J	3.25	83

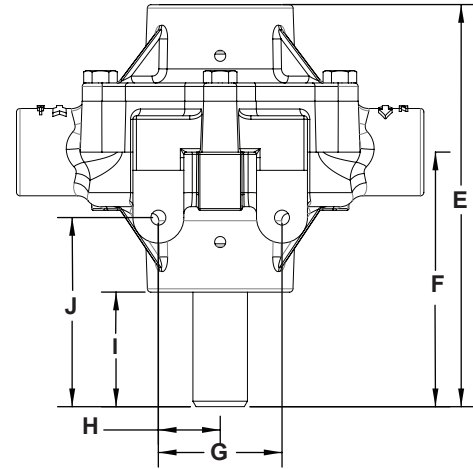
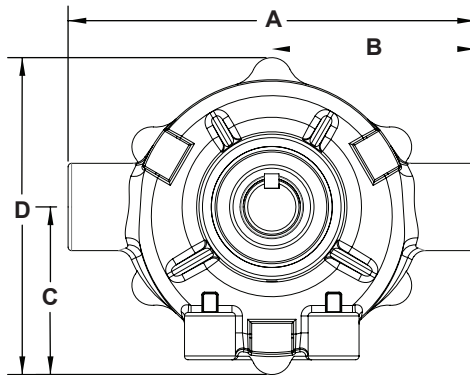

7560C, 7560N, 7560XL Pump Specifications										
Rollers:	Max. Flow Rate (GPM [LPM]):	Max. Pressure (PSI [BAR]):	Max RPM	Ports:	Shaft:	Continuous Operation (PSI [BAR]):	Intermittent Operation (PSI [BAR]):	Dry Weight (LBS [KG]):	Minimum Horsepower requirement	Mounting bolts
8	22.5 [85.2]	300 [20.7]	1000	-3/4" NPT Inlet & Outlet -1" Hose Barb included	15/16" Dia. (Solid)	100 [6.9]	300 [20.7]	13 [5.89]	6.1	2 X 5/16-18 UNC

Performance Data 7560C, 7560N, 7560XL						
Pressure	GPM	HP	GPM	HP	GPM	HP
	@540 RPM		@800RPM		@1000RPM	
0 PSI	12.0	0.3	18.3	0.9	22.5	1.6
50 PSI	11.1	0.7	17.5	1.3	22.0	1.8
100 PSI	10.3	1.3	16.9	2.0	21.3	2.5
150 PSI	9.5	1.8	16.1	2.7	20.6	3.5
200 PSI	8.6	2.3	15.5	3.4	20.0	4.2
250PSI	7.8	2.8	14.5	4.2	18.9	5.3
300PSI	7.1	3.3	13.7	4.9	18.0	6.1

Performance Data 7560C, 7560N, 7560XL						
Pressure	LPM	HP	LPM	HP	LPM	HP
	@540 RPM		@800RPM		@1000RPM	
0 BAR	45.4	0.3	69.3	0.9	85.2	1.6
3.4 BAR	42.0	0.7	66.2	1.3	83.3	1.8
6.9 BAR	39.0	1.3	64.0	2.0	80.6	2.5
10.3 BAR	36.0	1.8	60.9	2.7	78.0	3.5
13.8 BAR	32.5	2.3	58.7	3.4	75.7	4.2
17.2 BAR	29.5	2.8	54.9	4.2	71.5	5.3
20.7 BAR	26.9	3.3	51.9	4.9	68.1	6.1

# Pump Technical Data

## Hydraulic

Pump Dimensions		
Dim.	Inch	mm
A	7	178
B	2.44	62
C	4.21	107
D	5.08	129
E	6.1	155
F	3.58	91
G	13.58	345
H	4.69	119
I	2	51

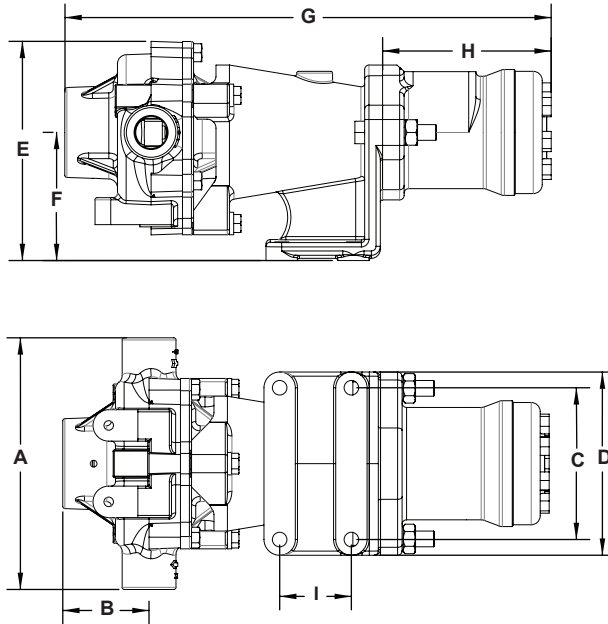

7560C-GM30, 7560N-GM30, 7560XL-GM30 Pump Specifications											
Rollers:	Max. Pump Flow Rate GPM [LPM]:	Max. Pump Pressure (PSI [BAR]):	Max RPM	Ports:	Hydraulic Motor Ports	Continuous Operation (PSI [BAR]):	Intermittent Operation (PSI [BAR]):	Dry Weight (LBS [KG])	Max. Hydraulic Flow (GPM [LPM])	Max Hydraulic Pressure (PSI [BAR])	Mounting bolts
8	20.8 [78.7]	300 [20.7]	1000	-3/4" NPT Inlet & Outlet -1" Hose Barb included	-10 SAE (7/8"-14 UNF)	100	300	13 [5.89]	6 [22.7]	2400 [165.5]	4 X 3/8 or M10

7560C-GM30, 7560N-GM30, 7560XL-GM30 Performance Data (Imperial)										
Hyd. GPM	GPM @ 0PSI	GPM @ 25 PSI	GPM @ 50 PSI	GPM @ 77 PSI	GPM @ 100 PSI	GPM @ 125 PSI	GPM @ 150 PSI	GPM @ 200 PSI	GPM @ 250 PSI	GPM @ 300 PSI
5	9.0	8.5	7.8	7.3	6.7	6.1	5.5	4.4	3.3	2.2
6	10.5	10.0	9.5	8.9	8.4	7.8	7.3	6.2	5.2	4.1
7	11.9	11.5	11.0	10.4	9.9	9.4	8.9	7.8	6.8	5.7
8	13.7	13.1	12.5	12.0	11.5	10.9	10.4	9.4	8.4	7.3
9	15.2	14.6	14.1	13.6	13.1	12.6	12.1	11.1	10.0	9.1
10	16.9	16.5	15.9	15.4	14.9	14.3	13.9	12.9	11.9	11.0
11	18.6	18.2	17.6	17.1	16.6	16.1	15.6	14.7	13.8	12.9
12	20.1	19.6	19.1	18.6	18.1	17.6	17.1	16.3	15.3	14.5

7560C-GM30, 7560N-GM30, 7560XL-GM30 Performance Data (Metric)											
Hyd. LPM	LPM @ 0 BAR	LPM @ 2 BAR	LPM @ 4 BAR	LPM @ 6 BAR	LPM @ 8 BAR	LPM @ 10 BAR	LPM @ 12 BAR	LPM @ 14 BAR	LPM @ 16 BAR	LPM @ 18 BAR	LPM @ 20 BAR
20	35.8	33.2	30.5	28.1	25.6	23.4	20.9	18.5	15.8	12.6	10.0
25	42.8	39.5	36.8	34.0	31.8	29.2	26.2	23.7	21.6	18.9	16.4
30	51.8	49.0	45.8	43.0	40.3	37.9	35.3	33.3	31.1	28.9	26.2
35	58.1	55.8	52.7	50.1	47.7	45.5	43.1	40.9	38.8	36.3	33.5
40	67.6	64.8	62.4	60.0	57.7	55.8	53.4	51.3	48.8	46.6	44.1
45	75.3	72.7	70.4	68.1	66.0	63.8	61.8	59.8	57.8	55.7	53.3

## Pump Technical Data

### Hydraulic - cont'd

7560C-GM15, 7560N-GM15, 7560XL-GM15 Pump Specifications											
Rollers:	Max. Pump Flow Rate (GPM [LPM]):	Max. Pump Pressure (PSI [BAR]):	Max RPM	Ports:	Hydraulic Motor Ports	Continuous Operation (PSI [BAR]):	Intermittent Operation (PSI [BAR]):	Dry Weight (LBS [KG])	Max. Hydraulic Flow (GPM [LPM])	Max Hydraulic Pressure (PSI [BAR])	Mounting bolts
8	20.8 [78.7]	300 [20.7]	1000	-3/4" NPT Inlet & Outlet -1" Hose Barb included	-10 SAE (7/8"-14 UNF)	100	300	13 [5.89]	6 [22.7]	2400 [165.5]	4 X 3/8 or M10

7560C-GM15, 7560N-GM15, 7560XL-GM15 (Imperial)										
Hyd. GPM	GPM @ 0 PSI	GPM @ 25 PSI	GPM @ 50 PSI	GPM @ 75 PSI	GPM @ 100 PSI	GPM @ 125 PSI	GPM @ 150 PSI	GPM @ 200 PSI	GPM @ 250 PSI	GPM @ 300 PSI
3	10.6	9.4	8.5	7.7	7.1	6.5	5.8	4.8	3.2	1.6
4	14.1	13.1	12.0	11.3	10.6	10.0	9.3	8.3	6.9	5.2
5	17.4	16.6	15.7	15.0	14.4	13.5	13.2	11.8	10.3	8.7
6	20.8	20.1	19.4	18.6	17.9	17.1	16.5	14.9	13.3	11.8

7560C-GM15, 7560N-GM15, 7560XL-GM15 (Metric)										
Hyd. LPM	LPM @ 0 BAR	LPM @ 1.7 BAR	LPM @ 3.5 BAR	LPM @ 5.2 BAR	LPM @ 6.9 BAR	LPM @ 8.6 BAR	LPM @ 10.3 BAR	LPM @ 13.8 BAR	LPM @ 17.2 BAR	LPM @ 20.7 BAR
11.4	40.1	35.6	32.2	29.1	26.9	24.6	22.0	18.2	12.1	6.1
15.1	53.4	49.6	45.4	42.8	40.1	37.9	35.2	31.4	26.1	19.7
18.9	65.9	62.8	59.4	56.8	54.5	51.1	50.0	44.7	39.0	32.9
22.7	78.7	76.1	73.4	70.4	67.8	64.7	62.5	56.4	50.3	44.7



# Pump Technical Data

## 7700 Series Pump Only

Pump Dimensions		
Dim.	Inch	mm
A	6.75	172
B	3.38	86
C	2.94	75
D	5.48	139
E	6.91	176
F	4.38	111
G	2.12	54
H	1.06	27
I	1.98	50
J	3.81	97
K	1.13	29

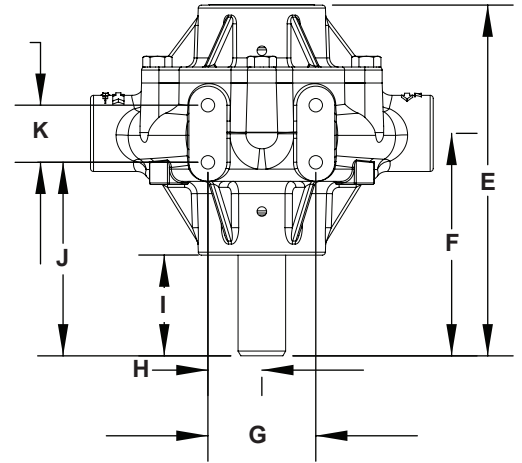
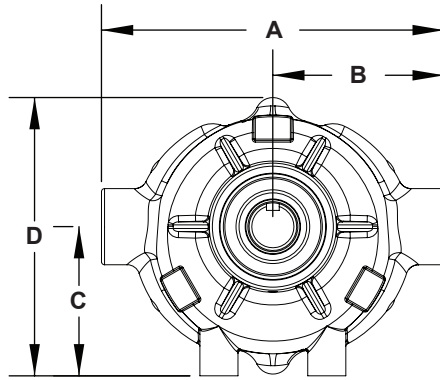

7700 Pump Specifications										
Rollers:	Max. Flow Rate (GPM [LPM]):	Max. Pressure (PSI [BAR]):	Max RPM	Ports:	Shaft:	Continuous Operation (PSI [BAR]):	Intermittent Operation (PSI [BAR]):	Dry Weight (LBS [KG]):	Minimum Horsepower requirement	Mounting bolts
7	22.4 [83.6]	200 [13.8]	800	-3/4" NPT Inlet & Outlet	15/16" Dia. (Solid)	100 [6.9]	200 [13.8]	14 [6.36]	3.26	4 X 5/16-18 UNC

Performance Data 7700 (Imperial)						
Pressure	GPM	HP	GPM	HP	GPM	HP
	@540 RPM		@600RPM		@800RPM	
0 PSI	14.2	0.2	15.3	0.3	22.1	0.4
50 PSI	12.9	0.6	14.0	0.6	20.7	0.9
100 PSI	11.9	1.1	13.0	1.2	19.5	1.7
150 PSI	11.2	1.6	12.3	1.8	18.6	2.4
200 PSI	10.3	2.2	11.6	2.4	17.8	3.3

Performance Data 7700 (Metric)						
Pressure	LPM	HP	LPM	HP	LPM	HP
	@540 RPM		@600RPM		@800RPM	
0 BAR	53.8	0.2	57.9	0.3	83.7	0.4
3.4 BAR	48.8	0.6	53.0	0.6	78.4	0.9
6.9 BAR	45.0	1.1	49.2	1.2	73.8	1.7
10.3 BAR	42.4	1.6	46.6	1.8	70.4	2.4
13.8 BAR	39.0	2.2	43.9	2.4	67.4	3.3

## Fluid Pumping Applications

Application	Pump Materials Compatibility			Comments
	Cast Iron	Ni-Resist	Silver Series XL	
<i>Weed Control Chemicals</i>	x	x	x	Use with super rollers and viton seals. When using with Roundup, use super or polypropylene rollers and Viton seals. Teflon rollers may be used with Roundup up to 100 PSI. Only Ni-Resist and Silver series pumps should be used with Roundup.
<i>Insect Control</i>	x	x	x	All pump, roller and seal combinations
<i>Brush Control</i>	x	x	x	Use super rollers and Viton seals
<i>Pest Control Chemical and Fumigants</i>				
<i>Liquid Fertilizers</i>		x	x	Use polypropylene rollers and Buna-N seals
<i>Powdered Fertilizers</i>	x	x	x	Use super rollers or polypropylene rollers with Buna-N or Viton seals
<i>Fluid Transfer</i>				
<i>Acids</i>			x	Use polypropylene or Teflon rollers with Viton seals. Limit pressure to 100 PSI when using Teflon rollers. DO NOT use super rollers with acids.
<i>x - Pump approved for application</i>				

**Table 1**

The following chemicals should never be put through any Hypro pump:

- Gasoline (Petrol)
- Kerosene/Kerosine (paraffin)
- Diesel fuel
- Ceramic slurries
- Sewage
- Potable water
- Abrasive fluids

## Tools

The Hypro roller pumps and mounting assemblies are designed with Imperial (inch) bolts, however, there are many metric (mm) sizes which will work with these bolts. In most cases, an adjustable spanner (crescent) wrench can also be used. disposed of in a manner which complies with local and national regulations. Never dump fluids onto the ground. Once the pump is free of all fluids, it may be scrapped in accordance with local and national laws.

## Lifting, Transport and Intermediate Storage

### Packaging Descriptions and Unpacking Instructions

- Hypro roller pumps are shipped in cardboard boxes for safe transporting.
- When pumps are shipped in large quantities, they may be put on a pallet to allow for easy storage, lifting and handling.
- Before lifting any pump or pallet, determine the weight of the item by looking at the attached packing slips to establish what lifting equipment or method should be used.
- Once the pump is unpacked, dispose of all the packaging in a manner compliant with local and national regulations.

### Lifting Instructions

- Before attempting to lift a Hypro pump, ensure that the surrounding working area is free of hazards which could cause injury or damage to property.
- During lifting operations, any personnel not involved in the lift should not enter the working area.
- If lifting hooks, rope or chains are being used for a lift, they must be free of damage and be rated to carry 150% of the weight of the load to be lifted.

## Lifting, Transport and Intermediate Storage - cont'd.

- **⚠** Always wear steel-toed shoes and cut-resistant gloves when attempting to lift.
- When lifting and carrying, always keep the pump close to your body. (See Figure 1)
- When starting the lift, bend your knees and keep your back straight. (See Figure 1) Tightening the stomach muscles will help keep your back straight.
- During the lift, use your legs to do the work. Never use your back, and make sure your legs are at least shoulder-width apart. (See Figure 1)

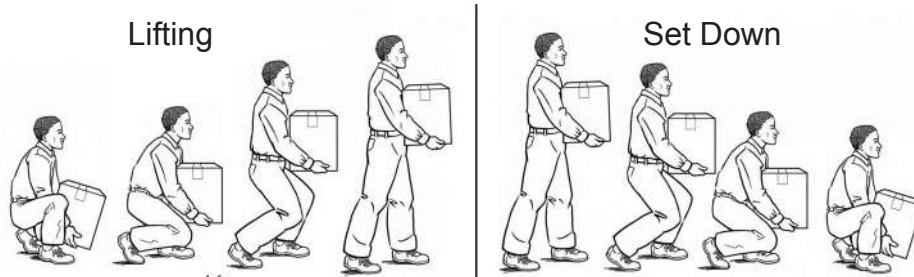

### Transport

- All Hypro pumps are capable of being transported by air, sea, rail or motor vehicle. When the pump is shipped, ensure that the pump is moved in accordance with local and national laws and is properly secured to prevent unwanted movement which could cause damage to person or property. Prior to shipping, all fluids should be removed from the pump.

### Storage

- New pumps in their boxes can be stored several years as long as the port plugs are not removed. Once the plugs have been removed, if the pump is not to be used for an extended period of time (i.e. more than 30 days), the pump must be winterized as described in the Cleaning section of this manual.

## Assembly and Installation

### Assembly

This pump comes completely assembled.

### Installation

Before attempting to install your Hypro centrifugal pump, it is imperative to read and understand the following:

- **⚠** Installation of a Hypro pump should only be performed by a technician having the knowledge and skills necessary to install the pump without the risk of property damage or personal injury.
- **⚠** When handling Hypro pumps, one should wear steel-toed shoes and protective gloves in order to protect the feet in the event the pump is dropped and protect the hands from any sharp surfaces on the pump or chemicals.
- **⚠** Pumping systems must be installed in accordance with Hypro installation instructions. Failure to do so will void your warranty and could cause damage to property, serious personal injury, or death.
- **⚠** Electrical power cables and pump hoses must be routed where there is no risk of personnel tripping, walking into, or falling because they have been routed in areas where personnel are expected to move. Electrical power cables and pump hoses should be routed according to local and national standards.
- **⚠** It is the installer's responsibility to conduct earth continuity tests between AC electric-drive motors, Hypro pumps, and metalwork of support structures and earth according to EN60204-1:2006/A1:2009, or its superseding standard, to confirm that all components that need to be connected to earth are satisfactorily bonded.
- **⚠** It is the installer's responsibility to conduct electrical tests in accordance with EN60204-1:2006/A1:2009, or its superseding standard, on finished pump assemblies.
- All connections to electrical components must be number, symbol, or color coded generally as recommended by EN60204-1:2006/A1:2009, or its superseding standard.
- **⚠** Installers must provide hydraulic components that are capable of withstanding maximum source pressure.

---

## Assembly and Installation - cont'd

---

- **⚠** The working pressure must be controlled by a pressure relief valve that is adjusted to operate at a maximum pressure of the hydraulic motor.
- **⚠** For pumps with gas engines, the exhaust must be directed away from operator and anyone standing nearby to ensure that exhaust fumes do not enter their breathing zone.
- If a rigid plumbing system is to be used on a Hypro roller pump, the system must be properly aligned with the inlet and outlet port
- **⚠** The working pressure must be controlled by a pressure relief valve that is adjusted to operate at 10% of the maximum system pressure.
- **⚠** When installing, adjusting or removing a Hypro roller pump, ensure that there are no objects which can fall on the installer and make certain that all machinery to which the pump is to be attached is turned off.
- **⚠** Pumps must be installed in a location where they are accessible for any necessary maintenance.
- **⚠** When a main electrical supply is needed to power electric-drive motors, installers are responsible for ensuring that a supply disconnect device, capable of isolating the machine from its electricity supply, be provided.
- **⚠** When hydraulic power is used, the system should contain a quick disconnect coupling that can be broken to isolate the pump.

### Standard Mounting

In order to prevent injury or damage to property, all Hypro pumps should be properly mounted to a solid base where there is no danger of the pump falling or breaking loose. All Hypro pumps come with mounting holes, which allow bolts to be put into the pump so it can be secured to a sturdy base. When mounting your Hypro roller pump, be sure to use bolts and nuts which are compatible with any chemicals that may come into contact with them as well as choosing the correct grade of bolt based on the pump weight and any expected loads.

### Tractor PTO Installation

The preferred method for mounting the torque arm (3430-0540) and pump to a tractor is with the chains going up to provide support for the pump (see Figure 2).

Attach the torque arm to the pump with the long side of the arm on the inlet side of the pump for mounting.

Mount the pump and torque arm to the PTO shaft using a Hypro series 1320, 1321 or 1323 coupler.

Attach the torque chain to the tractor frame with arm in horizontal position.

Attach the tensioning chain to the tractor frame while applying tension to the spring.

- **⚠** Do not attach torque arm to movable linkages.
- **⚠** Personnel should never be within 3 meters (9 ft.) of the pump while in operation.



FIGURE 2

# Assembly and Installation - cont'd

## Belt/Pulley Drive Installation

Belt and pulley drive systems are typically used to reduce pump speed. For determining proper pulley sizes, use the formula below as a guideline and use "A" or "B" section belts.

$$\frac{\text{MOTOR RPM}}{\text{PUMP RPM}} = \frac{\text{FLOW (@ RATED SPEED)}}{\text{FLOW (DESIRED)}} = \frac{\text{PUMP PULLEY DIA.}}{\text{MOTOR PULLEY DIA.}}$$

**EXAMPLE:**

Use a 1725 RPM electric motor to drive a pump at 950 RPM. Typically, a pulley diameter on the motor is 3.4 inches. The pump pulley diameter can be determined from the formula above:

$$\frac{1725 \text{ RPM}}{950 \text{ RPM}} = \frac{\text{Pump Pulley Diameter}}{3.4 \text{ inches}}$$

Solving this equation for the Pump Pulley diameter yields:

$$\frac{1725 \text{ RPM}}{950 \text{ RPM}} \times 3.4 \text{ inches} = 6.2 \text{ inches}$$

(1 inch = 2.54cm)

1. Install pulley or bushing/sheave combination onto pump and motor shaft. Mount pump next to the motor making sure pulleys are lined up properly. (See Figure 3 for proper pump and motor orientation.)

Use a straight edge as shown (Figure 4). Rotate to check for run-out and bent shafts and replace if found.

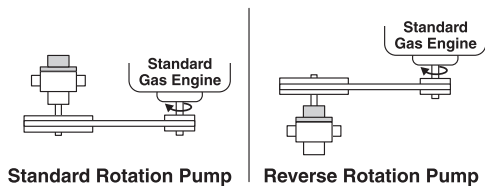

Figure 3

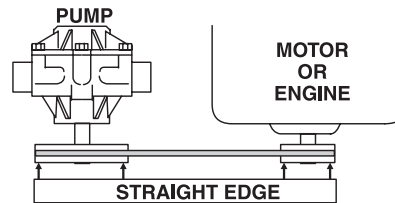
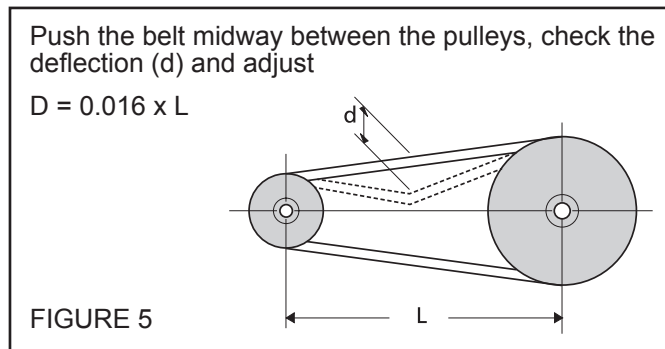

Figure 4

Make sure belts have proper tension - belts too tight will cause bearing wear and belts too loose will cause slipping (See Figure 5)



## Direct Drive-Flexible Coupling

When direct driving Hypro roller pumps with flexible couplings, make sure that the speed (rpm) of the gas engine or electric motor is within the maximum rated rpm of your pump (see performance tables). Also make sure that shaft rotation is correct between the pump and the motor or gas engine (see Figure 6).

1. Mount motor or engine into position on base.
2. Line up pump shaft with straight edge as shown in Figure 6 to assure they are aligned. Shim pump, if necessary, to match shaft height of engine or motor. Shaft ends should not touch.
3. Mark exact position of pump on base - remove and install coupling halves on both shafts. Place coupling center disc into one of the coupling halves.
4. Reposition pump, sliding coupling halves together.

**ATTENTION:** No end thrust should be applied to pump when coupling is connected

5. Tighten pump mounting; then tighten the set screws on each coupling.

# Assembly and Installation - cont'd

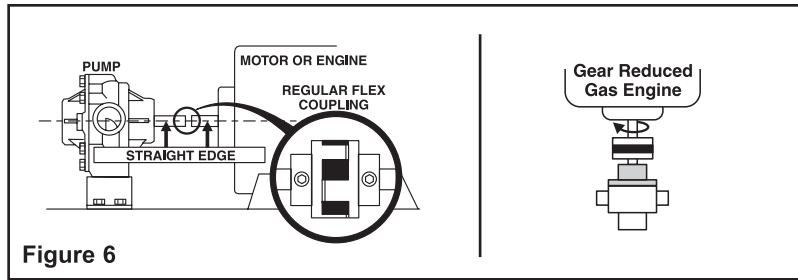

## System Installation

**ATTENTION:** Use only pipe, fittings, accessories, hose, etc. rated for the maximum pressure rating of the pump.

1. Select adequate size drive unit to avoid overloading. Avoid unnecessary restrictions in the line such as elbows, check valves, and all extraneous curves and bends.
2. Avoid using looped sections of tubing or pipe which might permit air to become trapped.
3. Use pipe joint sealant on pipe threads to assure watertight connections, and ensure that the sealant used is compatible with any chemicals which will be pumped.
4. Selection of the right size and type of hose is vital for good performance. Be sure to hook up to the proper ports on the pump (note markings and on pump label). "IN" "OUT"
  - a. Always use a suction hose compatible with the fluids being pumped and at least the same inside diameter as pump ports. If the suction hose is over 5 feet long, use one size larger hose. Keep the suction hose as short as possible and restrictions such as elbows, check valves, etc. at a minimum. Attention: Suction lift not to exceed 3 feet.
  - b. High pressure pumps require the use of special high pressure discharge hose. Use a hose rated at least 50% greater than the highest operating pressure of pump. Example: If required pump pressure is 300 psi [20.7 Bar], use hose rated at minimum of 450 psi [31.0 Bar] working pressure.
5. Use a suction line strainer with at least 3 to 5 times the suction port area in open screen area. Be sure the screen is suitable for the liquid being pumped. The mesh should be appropriate for the nozzle tip to be used, to avoid clogging.

**⚠ Never attach an agitator or any restriction to a bypass line of a pressure relief device because system damage may occur.**

Figure 7  
Typical System Installation

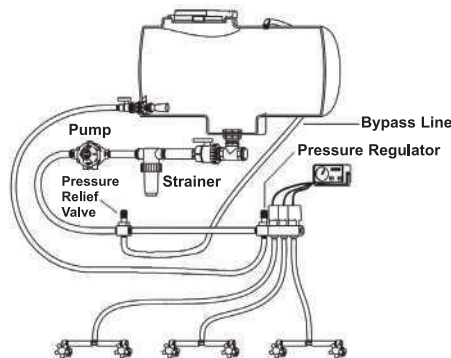

## ELECTRICAL HOOK-UP FOR UNITS SUPPLIED WITH DC MOTOR

The motor must be fused to protect the electrical system. Use a 35-amp slow-blow fuse or circuit breaker for -EH pumps and a 45-amp slow-blow fuse or circuit breaker for -E2H pumps.

The motor lead wires are identified by color with (+) being red and (-) being negative. For proper pump rotation, the connections should be made as follows:

- Positive Motor Lead (+) to Positive Power Lead (Red, +).
- Negative Motor Lead (-) to Negative Power Lead (Black, -).

## Assembly and Installation - cont'd.

### ON/OFF TOGGLE SWITCH INSTALLATION

See Figure 8.

1. The ON/OFF switch must be rated at or above 40 amps for -EH pumps
2. If additional lead wire is required, use 10 gauge or larger wire.
3. Performance may be improved by shortening the motor lead wires. Minimize wire length where possible.

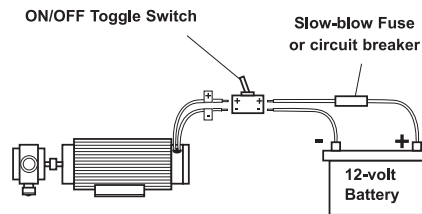

Figure 8

### Hooking up the Hydraulic Motor to the Tractor Hydraulic System

Hypro Series 7560 hydraulic motor-driven pumps can be mounted on either the tractor or sprayer. When hooking up, make sure that no dirt or liquid gets into the hydraulic motor. Series 7560 Keep all hydraulic connections clean. pumps utilize gear motor technology for high torque capacity and premium efficiency. Be sure to connect the hydraulic motor into the system correctly by putting the pressure line to the (IN) port and return line to the (OUT) port. For maximum performance, hose should be at least 1/2" (12.7mm). Be sure return line is appropriately sized and free of restrictions.

## Control System(s)

- All pump systems with electric or hydraulic power sources are required to have a control system which meets all local and national standards.
- **⚠** Overload and short-circuit protection devices should open at a current that is 10% higher than the normal load current.
- For more detail on a typical system installation, see the preceding subsections of the "Assembly and Installation" section of this manual.



### COMMISSIONING START-UP, OPERATION, SHUTDOWN

Before attempting to start your pump, the following must be understood and followed to ensure safe operation.

## Information

- **⚠** Only authorized operators having the knowledge and skill necessary to safely use a Hypro pump, or any equipment the pump is connected to, may run the pump.
- **⚠** When running Hypro roller pumps, it is essential that operators use hearing protection as the sound levels can reach levels of 80 decibels.
- **⚠** When handling Hypro pumps, wear steel-toed shoes and protective gloves in order to protect the feet in the event the pump is dropped and protect the hands from chemicals or any sharp surfaces on the pump.
- **⚠** When spraying manually, chemical-resistant facemasks and clothing should be worn to prevent any chemicals from coming into contact with the skin or being inhaled.
- **⚠** When spraying manually, always spray downwind of yourself as long as the sprayed chemical will not drift into the vicinity of other people.
- **⚠** When installing, adjusting or removing a Hypro roller pump, ensure that there are no objects which can fall on the installer, and make certain that all machinery to which the pump is to be attached is turned off.
- **⚠** Hypro roller pumps should only be used on tractors or tow-behind spray platforms which have electrically-conductive tires, in order to reduce the risk of electrocution.
- **⚠** Never operate a Hypro roller pump outside while there is a chance of getting struck by lightning.
- **⚠** Never leave electrical wires or plumbing components where they can be a tripping hazard or become entangled in a moving component. Ideally, electrical cables, hoses, pipes and fittings should be routed overhead. In the event electrical wiring must be routed over, the ground operators are required to use rubber ramps if they cross a gangway.

## Commissioning Start-Up, Operation, Shutdown - cont'd.

- If users of a Hypro roller pump are using a PTO shaft, flexible coupling or belt drive, they are required to use CE- approved PTO shafts and guards.
-  Hypro roller pumps should not be used if the ambient light is below 200lux.
-  For roller pumps which use gas engines, the user should always ensure the exhaust is properly attached to the engine and is not leaking.

 **Only use approved chemicals in your pump. For a complete list of approved chemicals, see the “FluidPumping Applications” section. Failure to follow this warning will void your warranty and could lead to property damage, serious injury or death.**

## Start-up, Start-Up, Operation, Shutdown

### Before Starting the Pump

Ensure all unnecessary personnel are clear of the area.

For initial setup and test of your system, it is recommended to start with clean water instead of chemicals, and confirm the system and plumbing connections are leak free.

Ensure that there is fluid in the source tank or supply line. Do not run dry.

Check line strainer for debris or clogs. Remove any found.

Check all plumbing connections to make sure they are tight. Check power source and connections.

Check that all valves and regulators are set to the desired setting and are functioning properly.

Ensure all hoses are properly positioned and are not damaged in any way.

Ensure PTO shaft shields are in place and are not loose.

### Priming the Pump

To help prime the pump, keep the inlet or suction line as short as possible with a minimum of bends, elbows and kinks. Make sure all connections are tight and do not leak air. Make sure line strainer is free of debris. If pump does not self-prime, disconnect suction hose, fill with water and reconnect to liquid source. Often a squirt of oil into the ports of the pump will seal clearances and help with priming.

### Pumps Equipped with Only DC Motor

#### Startup and Operation

Prior to operation, make sure all discharge lines and hoses are secure, and not frayed, and there are no personnel close to the pump. Make sure the tank valve / inlet line to the pump is open.

To start the pump, turn on main power switch to start the motor. Make sure pump is primed before proceeding. Adjust pressure to reach desired spray output.

#### Duty Cycle

Duty cycle is the ratio of motor-on time to total cycle time in one hour. It is used to determine the acceptable level of running time so that the thermal limits of the motor are not exceeded. Use the following equation and example to determine Duty Cycle:

Duty Cycle = ON TIME / [Cycle ON TIME + (60 Minutes - Cycle ON TIME)] \* 100. (ON TIME cannot exceed 60 minutes.)

An example of a 75% Duty Cycle Motor is = 45 / [45 + (60-45)] \* 100 = 75% or 45 minutes on time per hour of operation at maximum rated pressure and flow. ON TIME can be extended by reducing the maximum pressure the pump operates at.

Duty cycle is affected by ambient temperature. If operating in extremely hot environments, duty cycles will decrease. Do not run DC electric motors to an external operating temperature over 175° F (80° C), or the motor life will be compromised.

#### Shutdown

To shut down the unit, first turn the switch or power supply off, then close all valves. If the pump will not be used for several hours, it must be cleaned in accordance with the “Cleaning” section of this manual.



# Start-up, Start-Up, Operation, Shutdown

## Pumps Equipped with Hydraulic Motor

### Startup and Operation

#### Open Center Systems

The 7560 series pump hydraulic motors are not equipped, from the factory, with a bypass for excess hydraulic flow in a given system. In situations where the hydraulic system has more flow than the motor is rated for, an external bypass must be mounted to the hydraulic lines. Failure to restrict the pump to these levels may result in leaks and premature pump failure. To plumb the hydraulic motor into an open center hydraulic system that is not sized to the 7560 pump requirements, follow these installation instructions:

1. Ensure there is a bypass valve in the high pressure hydraulic line. Route bypass flow either to the return line or directly back to tank.
2. Prime the pump as above with all valves open.
3. Open hydraulic bypass all the way. Start hydraulic system and allow oil to circulate for approximately 10 to 15 minutes or until adequately warmed to 135°F (57°C).

**⚠** When operating a Hypro pump with a hydraulic motor, the maximum allowable temperature of the hydraulic fluid passing through the motor is 135°F (57°C).

4. Gradually close the hydraulic bypass valve until the pump reaches the desired pressure or flow.
5. Lock down the system hydraulic bypass valve in this position. DO NOT let the pump exceed its maximum pressure or flow. Failure to restrict the pump to these levels may result in leaks and premature failure.

#### Closed Center (Load Sensing) Systems

1. Set the system hydraulic flow control valve for minimum hydraulic oil flow to the remote outlet (Tortoise position).
2. Prime the pump as above with all valves open.
3. Start the hydraulic system and allow the hydraulic oil to circulate for approximately 10 to 15 minutes or until adequately warmed to 135°F (57°C).

**⚠** When operating a Hypro pump with a hydraulic motor, the maximum allowable temperature of the hydraulic fluid passing through the motor is 135°F (57°C).

4. Increase system hydraulic flow until pump reaches desired pressure or flow.
5. Lock down the system hydraulic bypass valve in this position. DO NOT let the pump exceed its maximum pressure or flow. Failure to restrict the pump to these levels may result in leaks and premature failure.

### Shutdown

Standard spool valves, which are found on all tractor hydraulic systems, may cause potentially damaging high peak pressures in the hydraulic system when closed because of abrupt shut-off of oil flow in both the supply and return lines. When shutting off the pump, move the selector to the FLOAT position to allow the pump to come to a stop gradually. If pump will not be used for several hours, it must be cleaned in accordance with the "Cleaning" section of this manual.

## PTO/Belt Drive/Flexible Coupling

### Startup and Operation





1. Prime the pump as described above with all valves open.
2. Start PTO/ Gas Engine/or Flexible coupling. If possible, slowly increase the RPM until the desired flow or pressure is reached. let the pump exceed its maximum pressure or flow. Failure to restrict the pump to DO NOT these levels may result in leaks and premature failure.

### Shutdown

Slowly decrease RPM until the pump comes to a stop, and then close all valves in the system. If pump will not be used for several hours, it must be cleaned in accordance with the "Cleaning" section of this manual.

# Maintenance and Servicing

## Information

-  All maintenance should be done when machinery is stationary and has been isolated from its energy sources. It is dangerous to perform maintenance while machinery is still connected to its power source. Machinery should be isolated from its electrical, hydraulic, shaft driven, or gas engine power source.
-  Be sure to release all pressure from the system before performing any sort of maintenance on a Hypro pump.
-  DO NOT perform service or maintenance to the pump, or attached components, until the pump unit is below 109°F (43°C).
-  The lubrication of this pump unit has been done at the factory prior to shipping.
-  When handling Hypro pumps, wear steel-toed shoes and protective gloves in order to protect your feet in the event the pump is dropped and protect your hands from chemicals or any sharp surfaces on the pump. If the pump is being repaired while the pump is in service, eye protection should also be worn.
- Any hazardous liquids should be disposed of in a manner which complies with local and national regulations. Never dump fluids onto the ground.

## Disposal

When disposing of a Hypro pump, be sure to remove all fluids from the pump before scrapping. These fluids should be disposed of in a manner which complies with local and national regulations. Never dump fluids onto the ground. Once the pump is free of all fluids, it must be scrapped in accordance with local and national laws.

## Cleaning

Your pump will last longer and give best performance when properly taken care of. Proper pump care depends on the liquid being pumped and when the pump will be used again. After each use, flush pump with a neutralizing solution for the liquid just pumped. Follow with a clean water rinse. This is especially important for corrosive chemicals. It is good practice to clean the pump after each use to prevent deposits from forming and damaging the pump. For infrequent use and before long periods of storage, drain pump thoroughly. Open any drain plugs, remove suction hose from liquid, and blow pump dry with air. An antifreeze/rust inhibitor should be injected into the pump before both ports are plugged and the pump is stored. Plug all ports to keep out air until pump is used again.

## Maintenance, Routine Servicing, and Inspection

### Preventative Maintenance Checklist

Check	Daily	Weekly
<i>Belt Tension</i>	x	
<i>Clean Filters</i>	x	
<i>Water Leaks</i>	x	
<i>Plumbing</i>		x

- Each system's maintenance cycle will be exclusive. If system performance decreases, check immediately.
- Duty cycle, temperature, quality and type of fluid being pumped, and inlet feed conditions all affect the life of pump, motor components, and service cycle.

## Maintenance, Routine Servicing, and Inspection

The following drawings show the pumps and their replacement parts.

-  Only genuine replacement parts should be used. Failure to follow this warning can result in damage to the pump malfunctions or is defective, it should be sent back to Hypro for property, serious injury or death. service.

# Replacement Parts

## Series 1502

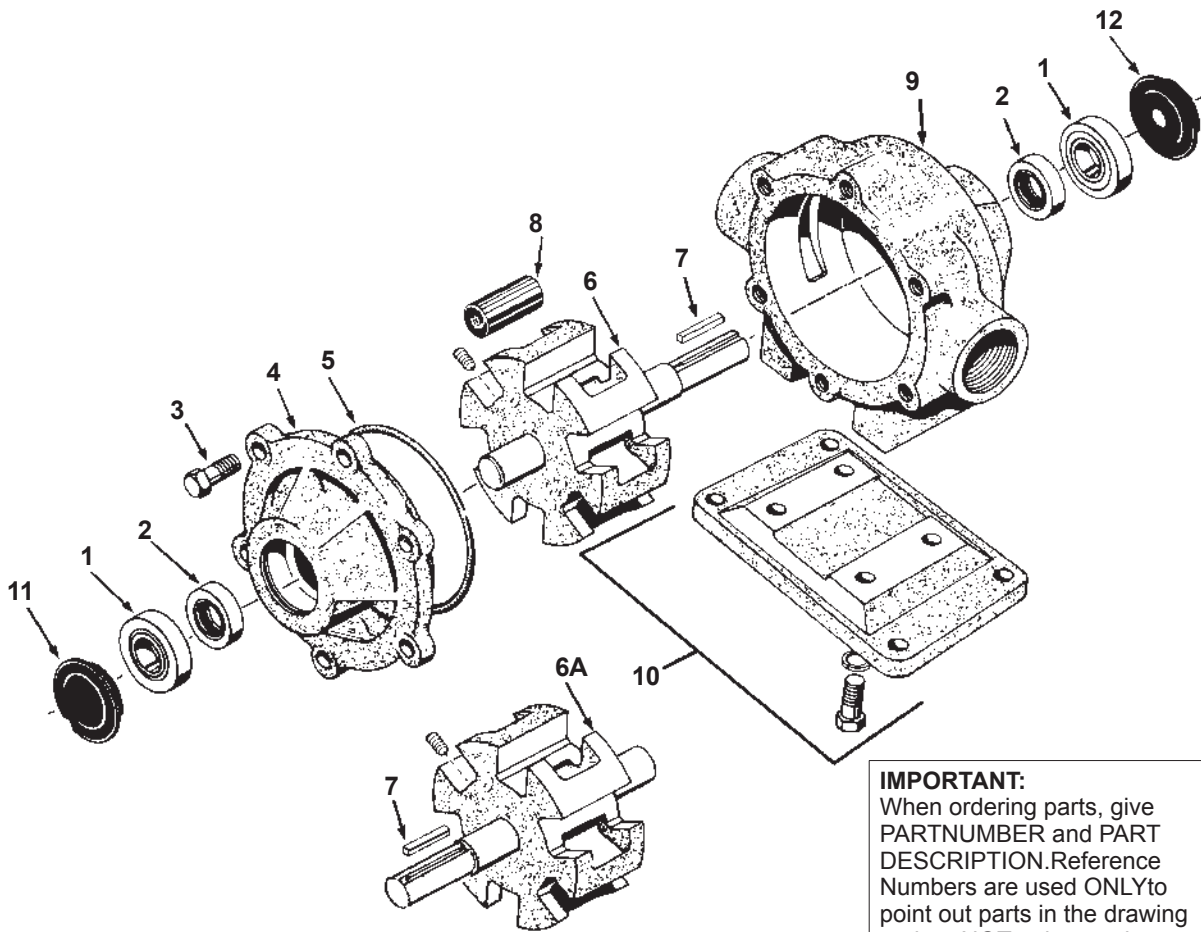

**IMPORTANT:**  
When ordering parts, give PARTNUMBER and PART DESCRIPTION. Reference Numbers are used ONLY to point out parts in the drawing and are NOT to be used as ordering numbers.

Ref. No.	Qty. Req'd.	Part No.	Description
1	2	2008-0001	Sealed Ball Bearing
2	2	2112-0001	Buna-N Seal (Standard)
2	2	2122-0003	Viton Seal (Optional) (Std. for SilverCast)
3	6	2210-0026	Bolt
4	1	0200-1500C	Endplate (Cast Iron) with Seal
4	1	0200-1500N	Endplate (Ni-Resist) with Seal
4	1	0200-1500X	Endplate (SilverCast) with Seal
5	1	1720-0003	O-ring Gasket for Endplate
6	1	0300-1502C	Rotor (Cast Iron) with shaft (Std. Rotation)
6	1	0300-1502N	Rotor (Ni-Resist) with shaft (Std. Rotation)
6	1	0300-1502X	Rotor (SilverCast) with shaft (Std. Rotation)
6A	1	0301-1502C	Rotor (Cast Iron) w/shaft (Reverse Rot.)
6A	1	0301-1502N	Rotor (Ni-Resist) w/shaft (Reverse Rot.)
6A	1	0301-1502X	Rotor (SilverCast) w/shaft (Reverse Rot.)

Ref. No.	Qty. Req'd.	Part No.	Description
7	1	1610-0005	Key
8	6	1005-0005	Super Roller (Standard)
8	6	1002-0005	Polypropylene Roller (Optional)
8	6	1055-0005	Teflon Roller (Optional)
9	1	0100-1500C	Body (Cast Iron) with Seal
9	1	0100-1500N	Body (Ni-Resist) with Seal
9	1	0100-1500X	Body (SilverCast with Seal)
10	1 kit	3420-0004	Base Kit - SOLD SEPARATELY Includes: (1) Base, (4) Bolts and (4) Lockwashers
11	1	2300-0020	Bearing Cover
12	1	2300-0022	Shaft Bearing Cover

**Repair Parts Kit No. 3430-0383 (Universal)** Consists of: (6) Ref. 8 Super Rollers, (1) Ref. 5 O-Ring Gasket, (1) O-ring Gasket (not shown), and (2) Ref. 2 Viton Seals.

**Repair Parts Kit No. 3430-0386** Consists of: (6) Ref. 8 Super Rollers, (1) Ref. 5 O-Ring Gasket, and (2) Ref. 2 Viton Seals.

**Repair Parts Kit No. 3430-0387** Consists of: (6) Ref. 8 Super Rollers, (1) Ref. 5 O-Ring Gasket, and (2) Ref. 2 Buna-N Seals.

**Repair Parts Kit No. 3430-0162** Consists of: (6) Ref. 8 Polypropylene Rollers and (1) Ref. 5 O-Ring Gasket.

**Repair Parts Kit No. 3430-0164** Consists of: (6) Ref. 8 Polypropylene Rollers, (1) Ref. 5 O-Ring Gasket, and (2) Ref. 2 Viton Seals.

**Repair Parts Kit No. 3430-0163** Consists of: (6) Ref. 8 Polypropylene Rollers, (1) Ref. 5 O-Ring Gasket, and (2) Ref. 2 Buna-N Seals.

**Repair Parts Kit No. 3430-0406** Consists of: (6) Ref. 8 Super Rollers, (1) Ref. 5 O-Ring Gasket, (2) Ref. 2 Viton Seals and (2) Ref. 1 Sealed Ball Bearing.

# Replacement Parts

## Series 1700

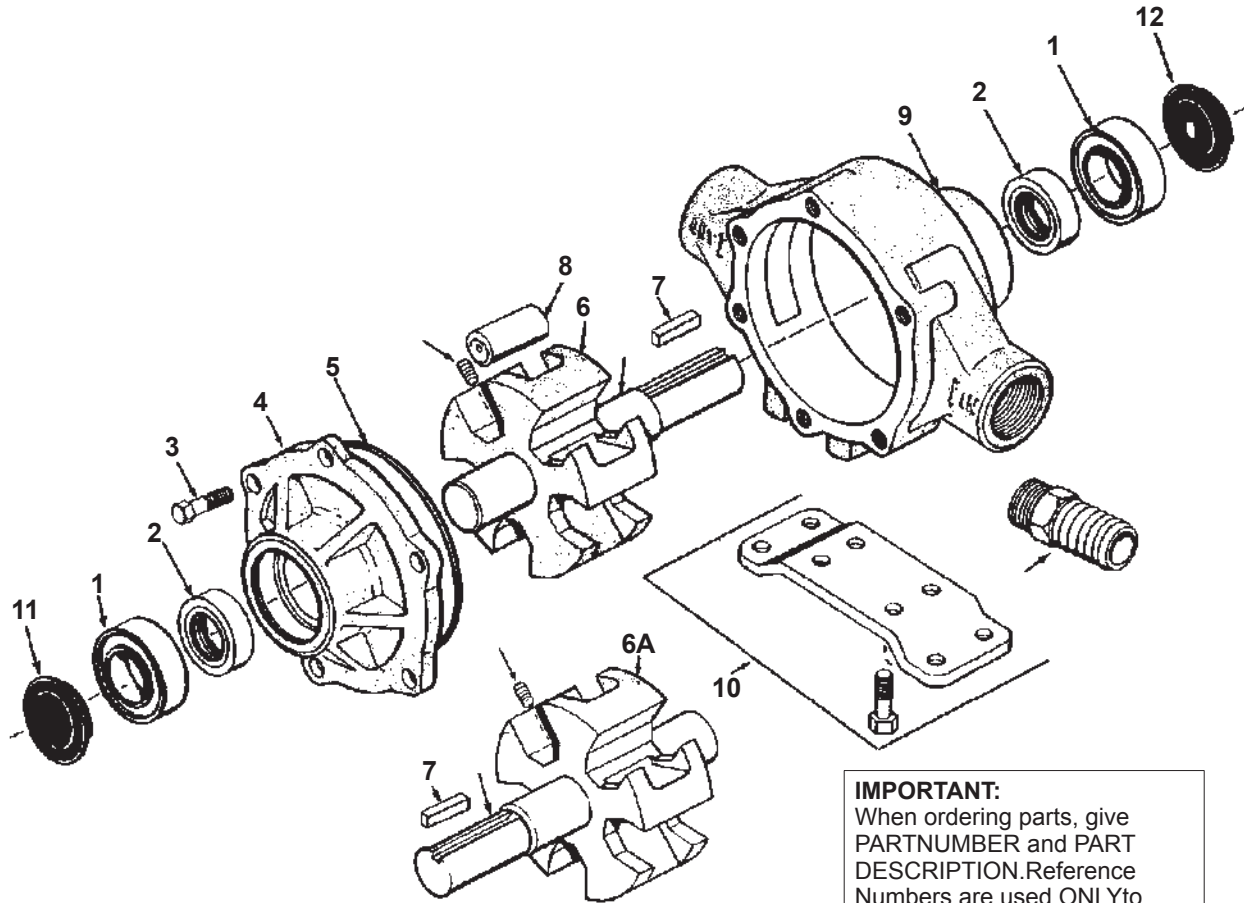

**IMPORTANT:**  
When ordering parts, give PARTNUMBER and PART DESCRIPTION. Reference Numbers are used ONLY to point out parts in the drawing and are NOT to be used as ordering numbers.

Ref. No.	Qty. Req'd.	Part No.	Description
1	2	2008-0001	Sealed Ball Bearing
2	2	2112-0001	Buna-N Seal (Standard)
2	2	2122-0003	Viton Seal (Optional) (Std. for SilverCast)
3	6	2210-0005	Bolt
4	1	0200-1700C	Endplate (Cast Iron) with Seal
4	1	0200-1700N	Endplate (Ni-Resist) with Seal
4	1	0200-1700X	Endplate (SilverCast) with Seal
5	1	1720-0099	O-ring Gasket for Endplate
6	1	0300-1700C	Rotor (Cast Iron) with shaft (Std. Rotation)
6	1	0300-1700N	Rotor (Ni-Resist) with shaft (Std. Rotation)
6	1	0300-1700X	Rotor (SilverCast) with shaft (Std. Rotation)
6A	1	0301-1700C	Rotor (Cast Iron) w/shaft (Reverse Rot.)
6A	1	0301-1700N	Rotor (Ni-Resist) w/shaft (Reverse Rot.)
6A	1	0301-1700X	Rotor (SilverCast) w/shaft (Reverse Rot.)

Ref. No.	Qty. Req'd.	Part No.	Description
7	1	1610-0005	Key
8	5	1005-0005	Super Roller (Standard)
8	5	1002-0005	Polypropylene Roller (Optional)
8	5	1055-0005	Teflon Roller (Optional)
9	1	0100-1700C	Body (Cast Iron) with Seal
9	1	0100-1700N	Body (Ni-Resist) with Seal
9	1	0100-1700X	Body (SilverCast with Seal)
10	1 kit	3420-0004	Base Kit - SOLD SEPARATELY Includes: (1) Base, (4) Bolts and (4) Lockwashers
11	1	2300-0020	Bearing Cover
12	1	2300-0022	Shaft Bearing Cover

**Repair Parts Kit No. 3430-0437** Consists of: (5) Ref. 8 Super Rollers, (1) Ref. 5 O-Ring Gasket, and (2) Ref. 2 Viton Seals.

**Repair Parts Kit No. 3430-0383 (Universal)** Consists of: (6) Ref. 8 Super Rollers, (1) Ref. 5 O-Ring Gasket, (1) O-ring Gasket (not shown), and (2) Ref. 2 Viton Seals.

**Repair Parts Kit No. 3430-0160** Consists of: (5) Ref. 8 Polypropylene Rollers and (1) Ref. 5 O-Ring Gasket, and (2) Ref. 2 Buna-N Seals.

**Repair Parts Kit No. 3430-0161** Consists of: (5) Ref. 8 Polypropylene Rollers and (1) Ref. 5 O-Ring Gasket, and (2) Ref. 2 Viton Seals.

**Repair Parts Kit No. 3430-0407** Consists of: (5) Ref. 8 Super Rollers, (1) Ref. 5 O-Ring Gasket, (2) Ref. 2 Viton Seals and (2) Ref. 1 Sealed Ball Bearing.

## Series 4001 and 4101

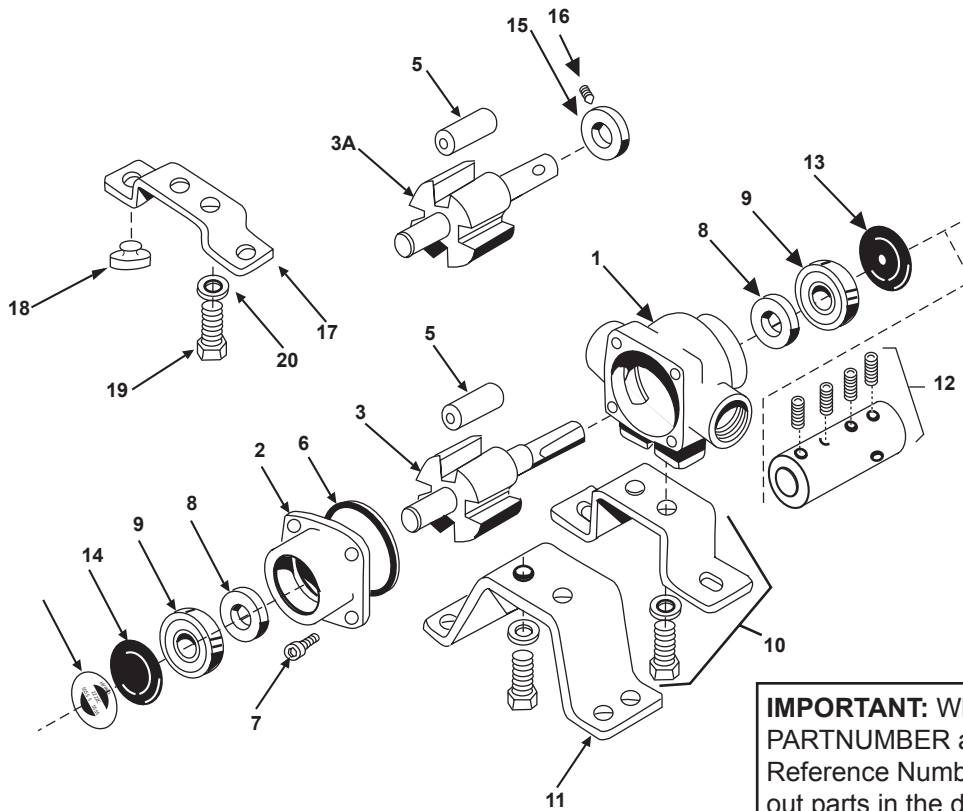

**IMPORTANT:** When ordering parts, give PARTNUMBER and PART DESCRIPTION. Reference Numbers are used ONLY to point out parts in the drawing and are NOT to be used as ordering numbers.

Ref. No.	Qty. Req'd.	Part No.	Description
1	1	0100-4001C	Body (Cast Iron) with Std. Seal (4001)
1	1	0100-4101C	Body (Cast Iron) with Std. Seal (4101)
1	1	0100-4001N	Body (Ni-Resist) with Std. Seal (4001)
1	1	0100-4101N	Body (Ni-Resist) with Std. Seal (4101)
1	1	0100-4001X	Body (SilverCast) with Std. Seal (4001)
1	1	0100-4101X	Body (SilverCast) with Std. Seal (4101)
2	1	0200-4001C	Endplate (Cast Iron) with Std. Seal (4001)
2	1	0200-4101C	Endplate (Cast Iron) with Std. Seal (4101)
2	1	0200-4001N	Endplate (Ni-Resist) with Std. Seal (4001)
2	1	0200-4101N	Endplate (Ni-Resist) with Std. Seal (4101)
2	1	0200-4001X	Endplate (SilverCast) with Std. Seal (4001)
2	1	0200-4101X	Endplate (SilverCast) with Std. Seal (4101)
3	1	0300-4001C	Rotor (Cast Iron) & Shaft Assembly (4001)
3	1	0300-4101C	Rotor (Cast Iron) & Shaft Assembly (4101)
3	1	3430-0765	Rotor Assembly (Std. 4001 Ni-Resist & XL)
3	1	3430-0766	Rotor Assembly (Std. 4101 Ni-Resist & XL)
3A	1	0301-4001C	Rotor Assembly (Cast Iron Hollow Shaft 4001C-H)
3A	1	0301-4101C	Rotor Assembly (Cast Iron Hollow Shaft 4101C-H)
3A	1	3430-0780	Rotor Assembly (Hollow Shaft 4001 Ni-Resist & XL)
3A	1	3430-0781	Rotor Assembly (Hollow Shaft 4101 Ni-Resist & XL)
5	4	1005-0002	Super Rollers (Std.)
5	4	1002-0002	Polypropylene Rollers (Optional)

Ref. No.	Qty. Req'd.	Part No.	Description
5	4	1055-0002	Teflon Rollers (Optional)
6	1	1720-0104	O-Ring Gasket for Endplate
7	4	2220-0018	Endplate Screw
8	2	2107-0002	Viton Seal (Std.)
8	2	2102-0001	Buna-N Seal (Optional)
8	2	2102-0001T	Teflon Coated Buna-N Seal (Optional)
9	2	2000-0010	Ball Bearing (High temp. grease)
10	1	3420-0024	Base Kit — <b>Sold Separately</b> Includes: 1 Base, 2 Bolts, and 2 Lock washers for mounting pump to electric motors with 3-1/2" shaft centerline
11	1	3420-0025	Base Kit — <b>Sold Separately</b> Includes: 1 Base, 2 Bolts, and 2 Lock washers for mounting pump to electric motors/gas engines with 4-3/16" shaft centerlines
12	1 kit	1320-0016	Adapter with 4 set screws for gas engine mount (5/8" x 5/8") — <b>Sold Separately</b>
12	1 kit	1320-0015	Adapter (5/8" x 3/4") — <b>Sold Separately</b>
13	1	2300-0023	Shaft Bearing Cover
14	1	2300-0021	Bearing Cover
15	1	1420-0001	Locking Collar
16	1	2230-0001	Set Screw
17	1	1510-0054	Base - <b>Sold Separately</b>
18	2	1450-0003	Bumper - <b>Sold Separately</b>
19	2	2210-0003	Bolt - <b>Sold Separately</b>
20	2	2260-0002	Lock Washer - <b>Sold Separately</b>

**Repair Parts Kit No. 3430-0390** Consists of: (4) Ref. 5 Super Rollers, (1) Ref. 6 O-Ring Gasket, (2) Ref. 8 Viton Seals.

**Repair Parts Kit No. 3430-0158** Consists of: (4) Ref. 9 Polypropylene Rollers, (1) Ref. 7 O-Ring Gasket, (2) Ref. 5 Viton Seals.

# Parts Illustration

## Models 4101C-25 and 4101XL-25

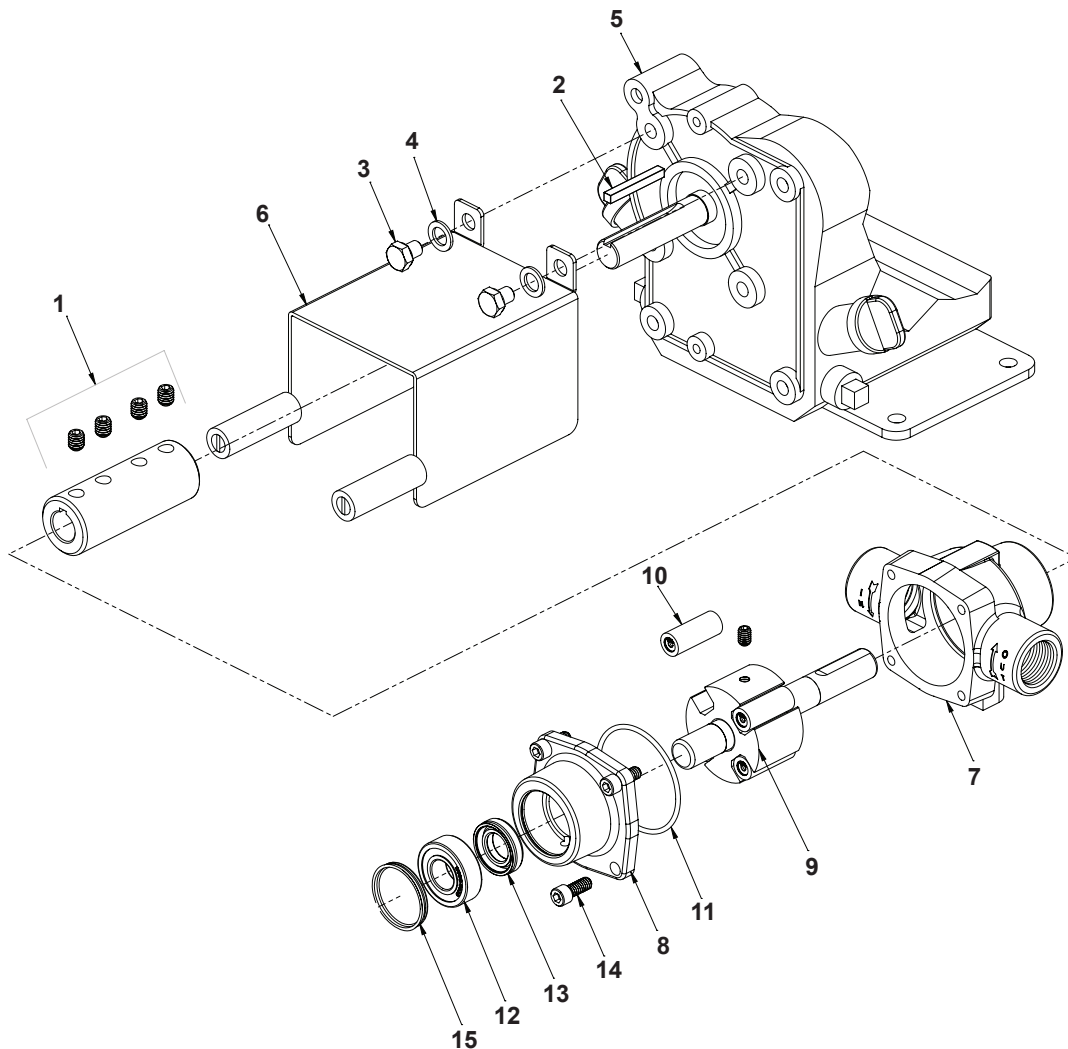

Ref. No.	Qty. Req'd.	Part No.	Description
1	1	1320-0016	Adapter and Kit
2	1	19209	Key 3/16 x 1-1/2"
3	2	2210-0166	Hed Head Capcrew
4	2	2270-0041	Washer
5	1	2549-0043	Engine: 2.5 HP PowerPro
6	1	2840-0084	Shield
7	1	0100-4101C	Body (Cast Iron) with Seal
7	1	0100-4101X	Body (SilverCast) with Seal
8	1	0200-4101C	Endplate (Cast Iron) with Seal
8	1	0200-4101X	Endplate (SilverCast) with Seal
9	1	0300-4101C	Rotor & Shaft Assembly (Cast Iron)
9	1	3430-0766	Rotor Assembly (SilverCast)
10	4	1005-0002	Super Rollers
11	1	1720-0104	O-ring Gasket for Endplate
12	2	2000-0010	Ball Bearing
13	2	2107-0002	Viton Seal
14	4	2220-0018	Socket Head Screw
15	1	2300-0021	Bearing Cover
16	1	2300-0023	Bearing Cover w/hole

### IMPORTANT:

When ordering parts, give PARTNUMBER and PART DESCRIPTION. Reference Numbers are used ONLY to point out parts in the drawing and are NOT to be used as ordering numbers.

Repair Parts Kit No. 3430-0390 Consists of: (4) Ref. 10 Super Rollers, (1) Ref. 11 O-Ring Gasket, (2) Ref. 13 Viton Seals.

## Series 4001 and 4101 Electric Motor-Driven Pumps

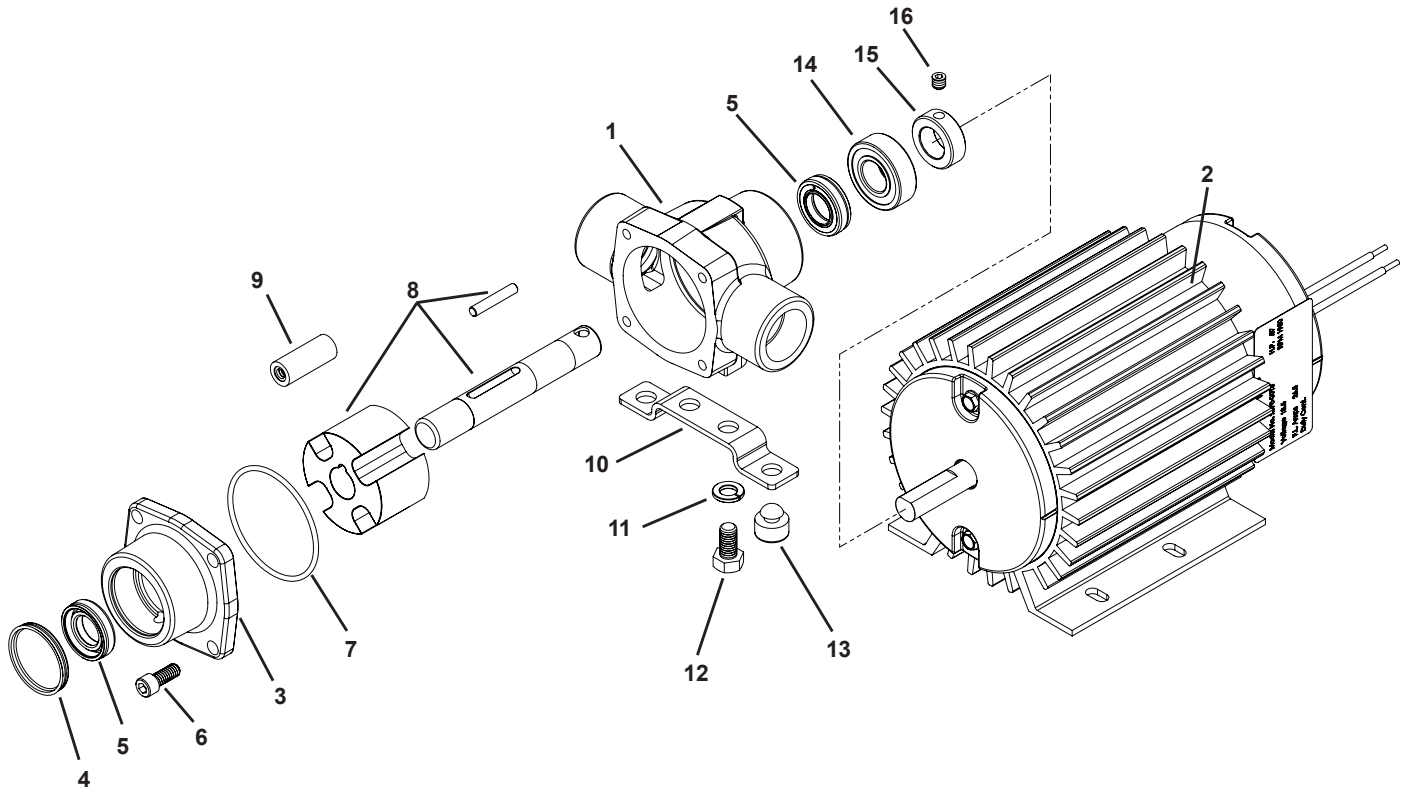

**IMPORTANT:** When ordering parts, give PARTNUMBER and PART DESCRIPTION. Reference Numbers are used ONLY to point out parts in the drawing and are NOT to be used as ordering numbers.

Ref. No.	Qty. Req'd.	Part No.	Description
1	1	0100-4001N	Body (Ni-Resist) with Std. Seal (4001)
1	1	0100-4101N	Body (Ni-Resist) with Std. Seal (4101)
1	1	0100-4001X	Body (SilverCast) with Std. Seal (4001)
1	1	0100-4101X	Body (SilverCast) with Std. Seal (4001)
2	1	2570-0013	Electric Motor (12 vdc, .39 hp) (gold)
2	1	2570-0015	Electric Motor (12 vdc, .39 hp) (black)
3	1	0200-4001N	Endplate (Ni-Resist) with Std. Seal (4001)
3	1	0200-4101N	Endplate (Ni-Resist) with Std. Seal (4101)
3	1	0200-4001X	Endplate (SilverCast) Std. Seal (4001)
3	1	0200-4101X	Endplate (SilverCast) Std. Seal (4101)
4	1	2300-0021	Bearing Cover
5	2	2107-0002	Viton Seal (Standard)
5	2	2102-0001	Buna-N Seal (Optional)
5	2	2102-0001T	Teflon-Coated Buna-N Seal (Optional)
6	4	2220-0018	Endplate Screw
7	1	1720-0104	O-ring Gasket for Endplate
8	1	3430-0780	Rotor Assembly (Std. 4001 Ni-Resist & XL Contains: rotor, shaft and pin
		3430-0781	Rotor Assembly (Std. 4101 Ni-Resist & XL Contains: rotor, shaft and pin

Ref. No.	Qty. Req'd.	Part No.	Description
9	4	1005-0002	Super Rollers (Standard)
9	4	1002-0002	Polypropylene Rollers (Optional)
9	4	1055-0002	Teflon Rollers (Optional)
10	1	1510-0054	Base
11	2	2260-0002	Lock Washer
12	2	2210-0003	Bolt
13	2	1450-0003	Bumper
14	2	2000-0010	Ball Bearing
15	1	1420-0001	Locking Collar
16	1	2230-0001	Set Screw
	1	4001N-H	Complete Roller Pump Assy (Not Shown)
	1	4001XL-H	Complete Roller Pump Assy (Not Shown)
	1	4101N-H	Complete Roller Pump Assy (Not Shown)
	1	4101XL-H	Complete Roller Pump Assy (Not Shown)

**Repair Parts Kit No. 3430-0390** Consists of: (4) Ref. 5 Super Rollers, (1) Ref. 6 O-Ring Gasket, (2) Ref. 8 Viton Seals.

**Repair Parts Kit No. 3430-0158** Consists of: (4) Ref. 9 Polypropylene Rollers, (1) Ref. 7 O-Ring Gasket, (2) Ref. 5 Viton Seals.

# Parts Illustration

## Series 6500

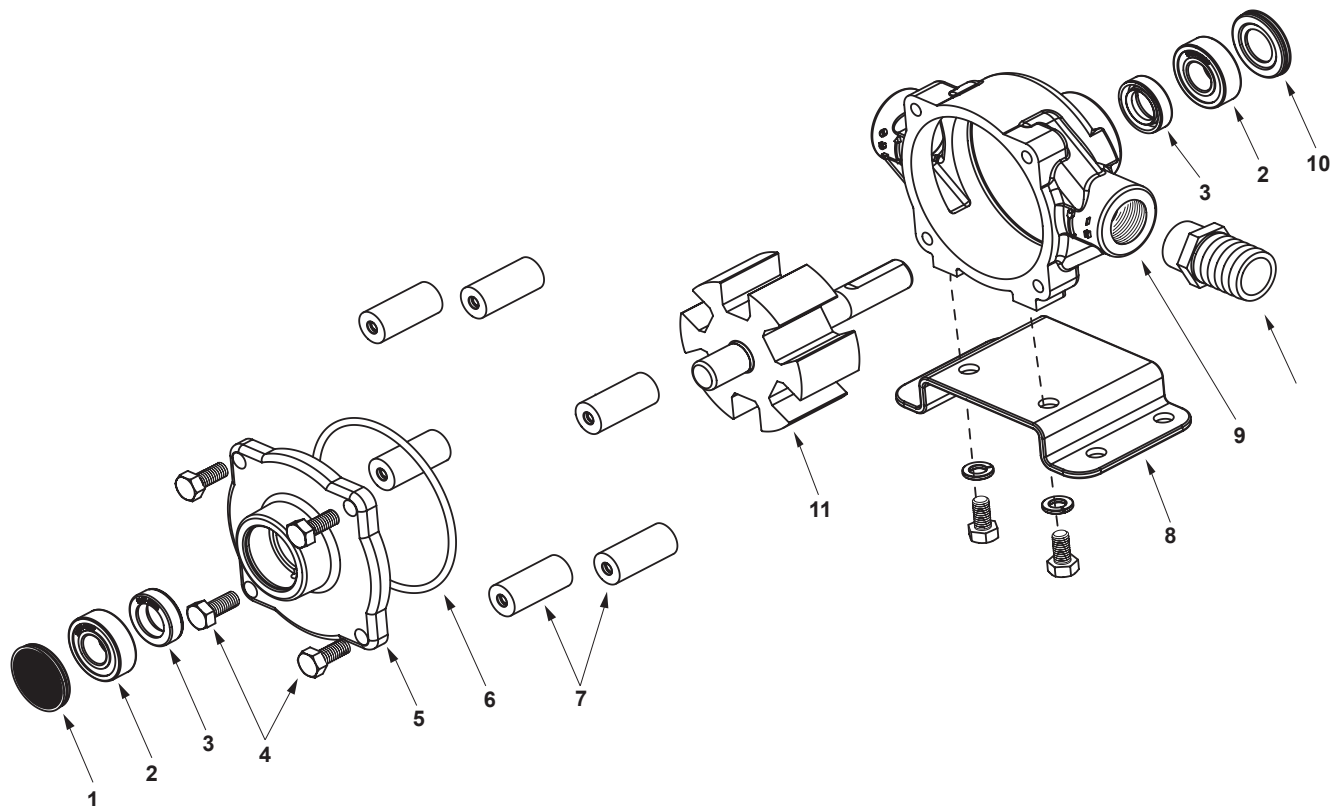

Ref. No.	Qty. Req'd.	Part No.	Description
1	1	2300-0021	Bearing Cover
2	2	2000-0010	Sealed Ball Bearing
3	2	2107-0002	Viton Seal (Standard)
3	2	2102-0001	Buna-N Seal (Optional)
3	2	2102-0001T	Teflon-coated Buna-N Seal
4	4	2210-0004	Bolts
5	1	0200-6600C	Endplate (Cast Iron) with Seal
5	1	0200-6600N	Endplate (Ni-Resist) with Seal
5	1	0200-6600X	Endplate (SilverCast) with Seal
6	1	1720-0008	O-ring Gasket for Endplate
7	6	1720-0104	Super Roller (Standard)
7	6	1002-0004	Polypropylene Roller (Optional)
7	6	1055-0004	Teflon Roller (Optional)
8	1 kit	3420-0023	Base Kit - <b>Sold Separately</b> Includes: (1) Base, (2) Bolts and (2) Washers
9	1	0100-6600C	Body (Cast Iron) with Seal
9	1	0100-6600N	Body (Ni-Resist) with Seal
9	1	0100-6600X	Body (SilverCast) with Seal
10	1	2300-0023	Shaft Bearing Cover
11	1	0300-6600C	Rotor Assembly (Cast Iron)
11	1	3430-0767	Rotor Assembly (Std. Ni-Resist & XL)

### IMPORTANT:

When ordering parts, give PARTNUMBER and PART DESCRIPTION. Reference Numbers are used ONLY to point out parts in the drawing and are NOT to be used as ordering numbers.

### Repair Parts Kits:

**No. 3430-0380** Consists of (6) Ref. 7 Super Rollers, (1) Ref. 6 O-ring, and (2) Ref. 3 Viton seals.

**No. 3430-0175** Consists of (6) Ref. 7 Polypropylene Rollers, (1) Ref. 6 O-ring, and (2) Ref. 3 Viton seals.



# Parts Illustration

## Series 7560

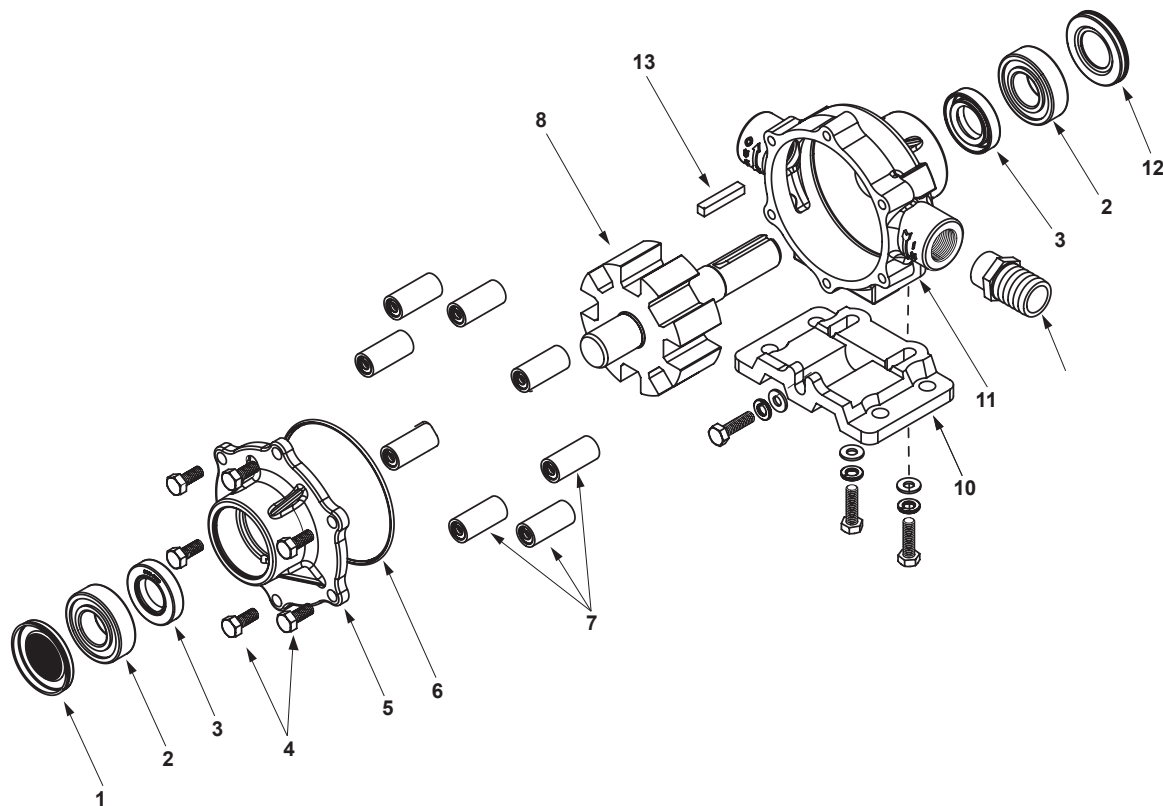

Ref. No.	Qty. Req'd.	Part No.	Description
1	1	2300-0021	Bearing Cover
2	2	2000-0010	Sealed Ball Bearing
3	2	2107-0002	Viton Seal (Standard)
3	2	2102-0001	Buna-N Seal (Optional)
4	6	2210-0004	Bolts
5	1	0200-6600C	Endplate (Cast Iron) with Seal
5	1	0200-6600N	Endplate (Ni-Resist) with Seal
5	1	0200-6600X	Endplate (SilverCast) with Seal
6	1	1720-0008	O-ring Gasket for Endplate
7	8	1720-0104	Super Roller (Standard)
7	8	1002-0004	Polypropylene Roller (Optional)
7	8	1055-0004	Teflon Roller (Optional)
8	1	3430-0745	Rotor Assembly (Std. Ni-Resist & XL)
8	1	0308-7560C	Rotor Assembly (Cast Iron Only)
10	1 kit	3420-0023	Base Kit - <b>Sold Separately</b> Includes: (1) Base, (3) Bolts and (3) Washers
11	1	0104-7500C	Body (Cast Iron) with Seal
11	1	0104-7500N	Body (Ni-Resist) with Seal
11	1	0104-7500X	Body (SilverCast) with Seal
12	1	2300-0022	Shaft Bearing Cover
13	1	1610-0005	Key
	1	1610-0059	Key (Stainless Steel)

### IMPORTANT:

When ordering parts, give PARTNUMBER and PART DESCRIPTION. Reference Numbers are used ONLY to point out parts in the drawing and are NOT to be used as ordering numbers.

### Repair Parts Kits:

**No. 3430-0381** Consists of (8) Ref. 7 Super Rollers, (1) Ref. 6 O-ring, and (2) Ref. 3 Viton seals.

**No. 3430-0167** Consists of (8) Ref. 7 Polypropylene Rollers, (1) Ref. 6 O-ring, and (2) Ref. 3 Viton seals.

## Parts Illustration

### Models 7560C-GM30, 7560N-GM30, and 7560XL-GM30 Models 7560C-GM15, 7560N-GM15, and 7560XL-GM15

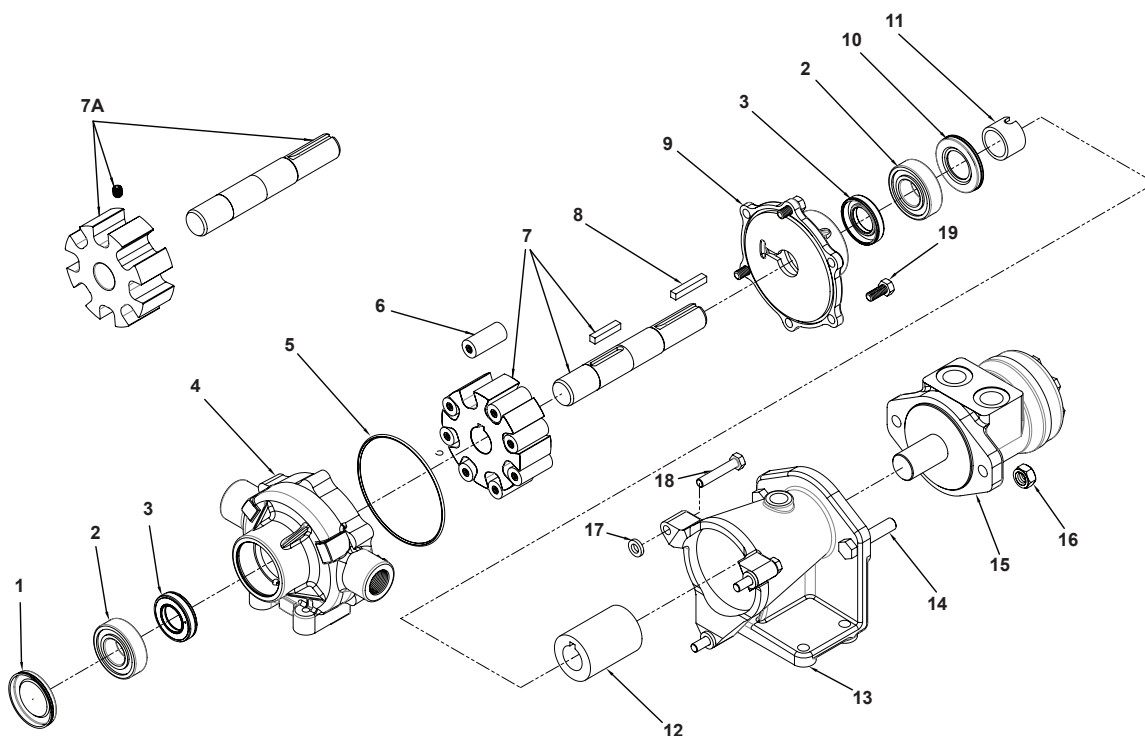

Ref. No.	Qty. Req'd.	Part No.	Description
1	1	2300-0021	Bearing Cover
2	2	2000-0010	Sealed Ball Bearing
3	2	2107-0002	Viton Seal (Standard)
3	2	2102-0001	Buna-N Seal (Optional)
3	2	2102-0001T	Teflon-coated Buna-N Seal
4	1	0104-7500C	Body (Cast Iron) with Seal
4	1	0104-7500N	Body (Ni-Resist) with Seal
4	1	0104-7500X	Body (SilverCast) with Seal
5	1	1720-0014	O-ring
6	8	1005-0004	Super Roller (Standard)
6	8	1002-0004	Polypropylene Roller (Optional)
6	8	1052-0004	Buna-N Roller (Optional)
6	8	1055-0004	Teflon Roller (Optional)
7	1	3430-0745	Rotor Assembly (Ni-Resist and SilverCast)
7A	1	0308-7560C	Rotor Assembly (Cast Iron)
8	1	1610-0005	Key
9	1	0204-7500C3	Endplate (Cast Iron) with Seal
9	1	0204-7500N3	Endplate (Ni-Resist) with Seal
9	1	0204-7500X3	Endplate (SilverCast) with Seal
10	1	2300-0022	Shaft Bearing Cover
11	1	1410-0111	Spacer
12	1	0524-2500	Coupler
13	1	0750-7500C	Mounting Flange
14	2	18044	Bolt
15	1	2500-0028	Hydraulic Motor (GM30)
15	1	2500-0042	Hydraulic Motor (GM15)
16	2	2250-0082	Nut
17	3	1410-0120	Spacer
18	3	11621	Bolt
19	3	2210-0004	Bolt

#### Repair Parts Kits:

**No. 3430-0381** Consists of: (8) Ref. 6 Super Rollers, (1) Ref. 5 O-Ring and (2) Ref. 3 Viton Seals.

**No. 3430-0167** Consists of: (8) Ref. 6 Polypropylene Rollers, (1) Ref. 5 O-Ring and (2) Ref. 3 Viton Seals.

**Flange Kit No. 3430-0636** Consists of: (1) Ref. 13 Mounting Flange, (1) Ref. 12 Coupler, (1) Ref. 11 Spacer, (2) Ref. 14 Bolts, (2) Ref. 16 Nuts, (3) Ref. 18 Bolts and (1) Ref. 8 Key.

**Replacement Pump, No Motor 7560C-RX, 7560N-RX, and 7560XL-RX**

# Parts Illustration

## Series 7700

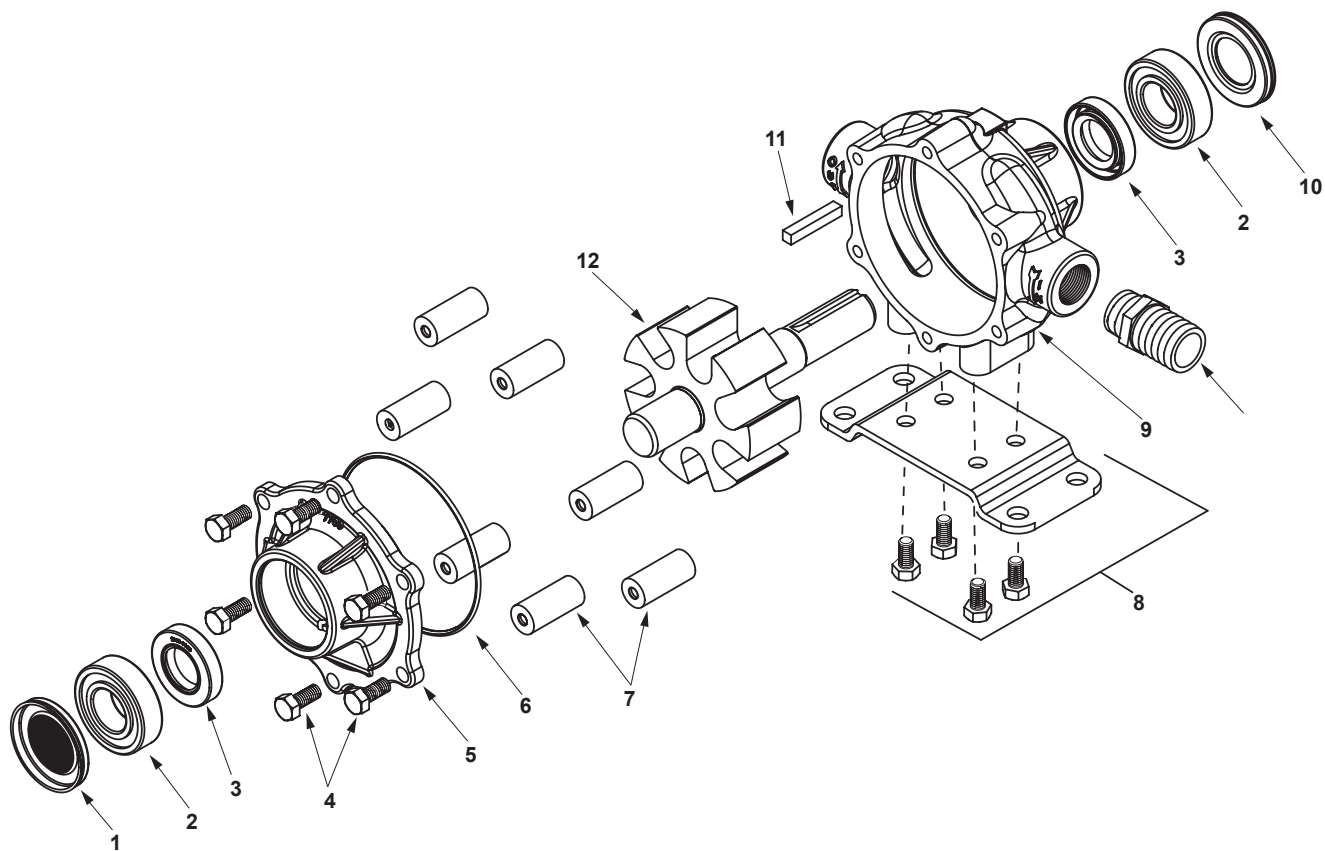

Ref. No.	Qty. Req'd.	Part No.	Description
1	1	2300-0020	Bearing Cover
2	2	2008-0001	Sealed Ball Bearing
3	2	2112-0003	Viton Seal (Standard)
3	2	2112-0001	Buna-N Seal (Optional)
4	6	2210-0004	Bolts
5	1	0200-7700C	Endplate (Cast Iron) with Seal
5	1	0200-7700N	Endplate (Ni-Resist) with Seal
5	1	0200-7700X	Endplate (SilverCast) with Seal
6	1	1720-0014	O-ring Gasket for Endplate
7	7	1005-0004	Super Roller (Standard)
7	7	1002-0004	Polypropylene Roller (Optional)
7	7	1055-0004	Teflon Roller (Optional)
8	1 kit	3420-0010	Base Kit - <b>Sold Separately</b> Includes: (1) Base, (4) Bolts
9	1	0100-7700C	Body (Cast Iron) with Seal
9	1	0100-7700N	Body (Ni-Resist) with Seal
9	1	0100-7700X	Body (SilverCast) with Seal
10	1	2300-0022	Shaft Bearing Cover
11	1	1610-0005	Key
12	1	0300-7700C	Rotor Assembly (Cast Iron)
12	1	0300-7700N	Rotor Assembly (Ni-Resist)
12	1	0300-7700X	Rotor Assembly (SilverCast)
12	1	0301-7700C	Rotor Assembly (Cast Iron) <b>Rev. Rot.</b>
12	1	0301-7700N	Rotor Assembly (Ni-Resist) <b>Rev. Rot.</b>
12	1	0301-7700X	Rotor Assembly (SilverCast) <b>Rev. Rot.</b>

### IMPORTANT:

When ordering parts, give PARTNUMBER and PART DESCRIPTION. Reference Numbers are used ONLY to point out parts in the drawing and are NOT to be used as ordering numbers.

### Repair Parts Kits:

**No. 3430-0384** Consists of (7) Ref. 7 Super Rollers, (1) Ref. 6 O-ring, and (2) Ref. 3 Viton seals

# Troubleshooting

## Troubleshooting Guide

Before attempting to service your pump, be sure that it is disconnected from all energy sources.

Symptom	Probable Cause(s)	Corrective Action
<i>Pump does not prime</i>	Leak in suction line	Check hose and fittings for leaks and correct
	Obstruction in suction line	Inspect hose for obstructions such as debris or loose inner liner and remove from the line
	Suction hose sucked to bottom or side of tank	Cut a notch or "V" in end of suction hose
	Rollers stuck in pump	Disassemble pump and inspect rollers
	pump seals leaking air	Replace seals
	pump turning in wrong direction	correct rotation of pump
<i>Loss of Pressure</i>	Clogged suction strainer	Check strainer and clean regularly
	Kinked or blocked suction hose	Inspect suction hose and repair as necessary
	Air leak in inlet side plumbing	Check hose and connections for leaks. Use pipe joint sealant and retighten connections
	Relief valve setting too low or weakend spring	Check relief valve and correct setting or replace spring
	Faulty gauge	Replace gauge
	Pump seals leak air	Replace seals
	Nozzle orifices worn	Replace Nozzles
	Pump worn	Repair Pump (See Repair Instructions)
<i>Pump will not turn</i>	Corrosion (rust), scale or residue	Replace pump
	Solid object lodged in pump	Disassemble pump and remove objects
<i>Hydraulic system overheating</i>	Improper hydraulic motor size	Refer to Pump Selection Guide to determine proper size for your hydraulic system
	Insufficient hydraulic hose size	Check hydraulic hose size. Hose should be at least 1/2" (12.7mm). For large open-center systems, hose should be 3/4" (19.05mm)

**Table 2**

## Reversing Rotation

1. Determine the rotor type of your pump by referring to exploded drawing on the parts list. The three types of rotors are NON-SCOOP, SCOOPED, and SLANTED SLOT.
2. Follow the steps listed in Repair Instructions for disassembly of the pump.
3. If your pump has a NON-SCOOP rotor (4001, 4101, 6500, 7560), it can be reversed merely by turning the rotor/shaft assembly around intact (without changing the position of the rotor on the shaft). Reassemble the pump with the driving end of shaft out the endplate side of the pump. (Standard pump rotors are driven from the body side.)
4. If your pump has a SCOOPED rotor (1500, 1700) or a SLANTED SLOT (7700) rotor, follow the following steps for reversing the shaft in the rotor.
  - Loosen and remove the rotor set screw.
  - Press the shaft out of the rotor.
  - Reassemble the shaft and rotor with the driving end of shaft on the opposite side of the rotor from standard assembly.
  - Before installing the rotor on the shaft, be sure it is positioned in the correct location on the shaft (diameter of shaft is slightly larger at rotor position). Center punch the shaft through rotor set screw hole. Then with a drill smaller than set screw - spot drill shaft so that set screw will hold securely. (Don't drill too deep - just enough so set screw will bite into shaft).
  - Reassemble the pump with driving end of shaft extending out of side of pump. (The endplate standard pump rotor is driven from the side.) body Remember, the rotor position remains the same - the shaft only is reversed - "end for end."

**Note: Configuration is opposite from above for 4001 and 4101 series.**

### Standard NON-SCOOP Rotor

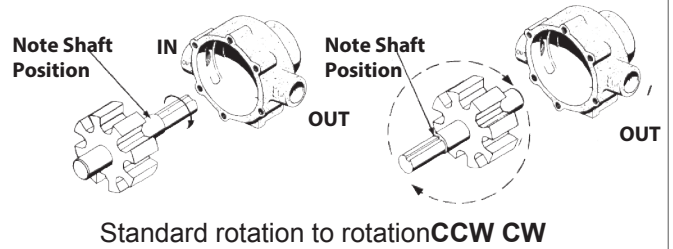

Figure A

### SCOOPED Rotor

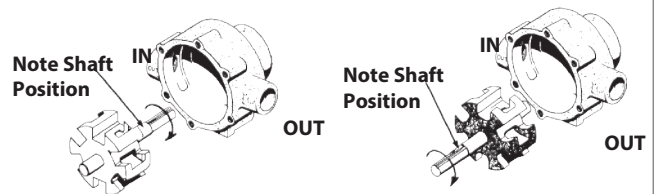

Figure B

### SLANTED SLOT Rotor

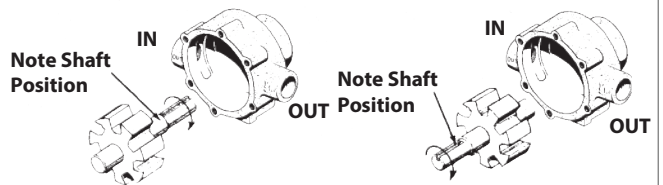

Figure C

Diagram of 7-roller rotor with special slanted, wide roller slots (Series



7700). Note that slots should slant back from rotation direction.

## Notes

## Notes

# EC Declaration of Incorporation

**Manufacturer's Name:** Pentair Flow Technologies, LLC  
**Manufacturer's Address:** 375 Fifth Avenue NW,  
New Brighton, MN 55112, USA

Declare that the partially complete machinery described below conforms to applicable health and safety requirements of Parts 1 of Annex I of Machinery Directive 2006/42/EC. This partly completed machinery must not be put into service until the equipment into which it is to be incorporated has been declared in conformity with the provisions of this directive. Confidential technical documentation has been compiled as described in Annex VII Part B of Machinery Directive 2006/42/EC and is available to European national authorities on written request. If a request is received, documentation will be transmitted either electronically or by post. Clauses 1.1.4, 1.1.7, 1.1.8 Section 1.2, Clauses 1.3.5, 1.3.6, 1.3.7, 1.3.8.1, 1.3.8.2, 1.3.9, 1.4.1, 1.4.2.1, 1.4.2.2, 1.4.2.3, 1.4.3, 1.5.2, 1.5.7, 1.5.12, 1.5.14, 1.5.16, 1.6.2, 1.7.1.1, 1.7.1.2, 1.7.2, and 1.7.4.2 are clauses of Machinery Directive 2006/42/EC that have not been met, but could be applicable and must be addressed during installation by a third party.

**Description:** PENTAIR Pump

**Type:** Roller Pumps

**Series Numbers:** 1502, 1700, 4001, 4101, 6500, 7560, 7700

**Type:** Centrifugal Pumps

**Series Numbers:** 1442P, 9000, 9202, 9203, 9205, 9206, 9208, 9262, 9263, 9253, 9302, 9303, 9305, 9306, 9307, 9308

The following standards have either been referred to or been complied with in part or in full as relevant:

ENISO 12100	Machinery Safety	General principles for design - Risk assessment and risk reduction
EN809-1998 + A1 2009	Machinery Safety	Pumps and pump units for liquids - Common safety requirements
EN ISO 13732-1	Machinery Safety	Ergonomics of the thermal environment
EN ISO 3744:2010	Acoustics	Determination of sound power levels and sound energy levels of noise sources using sound pressure
EN ISO 11202/A1 1997	Machinery Safety	Noise emitted by machinery and equipment
EN 12162:2001+A1:2009	Machinery Safety	Liquid pumps - Safety requirements - Procedure for hydrostatic testing
EN ISO 4254-6:2009	Machinery Safety	Sprayers and liquid fertilizer distributors
97-68-EC + 2010/26/EU	Gas Emission	Non-road gas emissions

**Name** ..... **Position** .....

**Signature** ..... **Date** .....

**Place of Signing**.....



**QNET BV**  
**Hommerterweg 286**  
**6436 AM Amstenrade**  
**The Netherlands**



## Limited Warranty on Hypro/Shurflo Agricultural Pumps & Accessories

Hypro/Shurflo (hereafter, "Hypro") agricultural products are warranted to be free of defects in material and workmanship under normal use for the time periods listed below, with proof of purchase.

- Pumps: one (1) year from the date of manufacture, or one (1) year of use. This limited warranty will not exceed two (2) years, in any event.
- Accessories: ninety (90) days of use.

This limited warranty will not apply to products that were improperly installed, misapplied, damaged, altered, or incompatible with fluids or components not manufactured by Hypro. All warranty considerations are governed by Hypro's written return policy.

Hypro's obligation under this limited warranty policy is limited to the repair or replacement of the product. All returns will be tested per Hypro's factory criteria. Products found not defective (under the terms of this limited warranty) are subject to charges paid by the returnee for the testing and packaging of "tested good" non-warranty returns.

No credit or labor allowances will be given for products returned as defective. Warranty replacement will be shipped on a freight allowed basis. Hypro reserves the right to choose the method of transportation.

This limited warranty is in lieu of all other warranties, expressed or implied, and no other person is authorized to give any other warranty or assume obligation or liability on Hypro's behalf. Hypro shall not be liable for any labor, damage or other expense, nor shall Hypro be liable for any indirect, incidental or consequential damages of any kind incurred by the reason of the use or sale of any defective product. This limited warranty covers agricultural products distributed within the United States of America. Other world market areas should consult with the actual distributor for any deviation from this document.

### Return Procedures

All products must be flushed of any chemical (ref. OSHA section 1910.1200 (d) (e) (f) (g) (h)) and hazardous chemicals must be labeled/tagged before being shipped\* to Hypro for service or warranty consideration. Hypro reserves the right to request a Material Safety Data Sheet from the returnee for any pump/product it deems necessary. Hypro reserves the right to "disposition as scrap" products returned which contain unknown fluids. Hypro reserves the right to charge the returnee for any and all costs incurred for chemical testing, and proper disposal of components containing unknown fluids. Hypro requests this in order to protect the environment and personnel from the hazards of handling unknown fluids.

Be prepared to give Hypro full details of the problem, including the model number, date of purchase, and from whom you purchased your product. Hypro may request additional information, and may require a sketch to illustrate the problem.

**Contact Hypro Service Department at 800-468-3428 to receive a Return Merchandise Authorization number (RMA#).** Returns are to be shipped with the RMA number clearly marked on the outside of the package. Hypro shall not be liable for freight damage incurred during shipping. Please package all returns carefully. All products returned for warranty work should be sent **shipping charges prepaid** to:

HYPRO / PENTAIR  
Attention: Service Department  
375 Fifth Avenue NW  
New Brighton, MN 55112

For technical or application assistance, call the **Hypro Technical/Application number: 800-445-8360**, or send an email to: **technical@hypropumps.com**. To obtain service or warranty assistance, call the **Hypro Service and Warranty number: 800-468-3428**; or send a fax to the **Hypro Service and Warranty FAX: 651-766-6618**.

\*Carriers, including U.S.P.S., airlines, UPS, ground freight, etc., require specific identification of any hazardous material being shipped. Failure to do so may result in a substantial fine and/or prison term. Check with your shipping company for specific instructions.

Visit [www.hypropumps.com/register](http://www.hypropumps.com/register) today to register your product and stay up-to-date on new products and promotional offers.

The following information is required:

Model # \_\_\_\_\_ Serial # \_\_\_\_\_



375 Fifth Avenue NW • New Brighton, MN 55112 USA  
Phone: (651) 766-6300 • 800-424-9776 • Fax: 800-323-6496  
[www.hypropumps.com](http://www.hypropumps.com)