

INSTRUCTION MANUAL

2 GAL. FOAM MARKER ATTACHMENT

Models: SG42, SG46, & SG52



2 GALLON FOAM MARKER EXPLODED VIEW

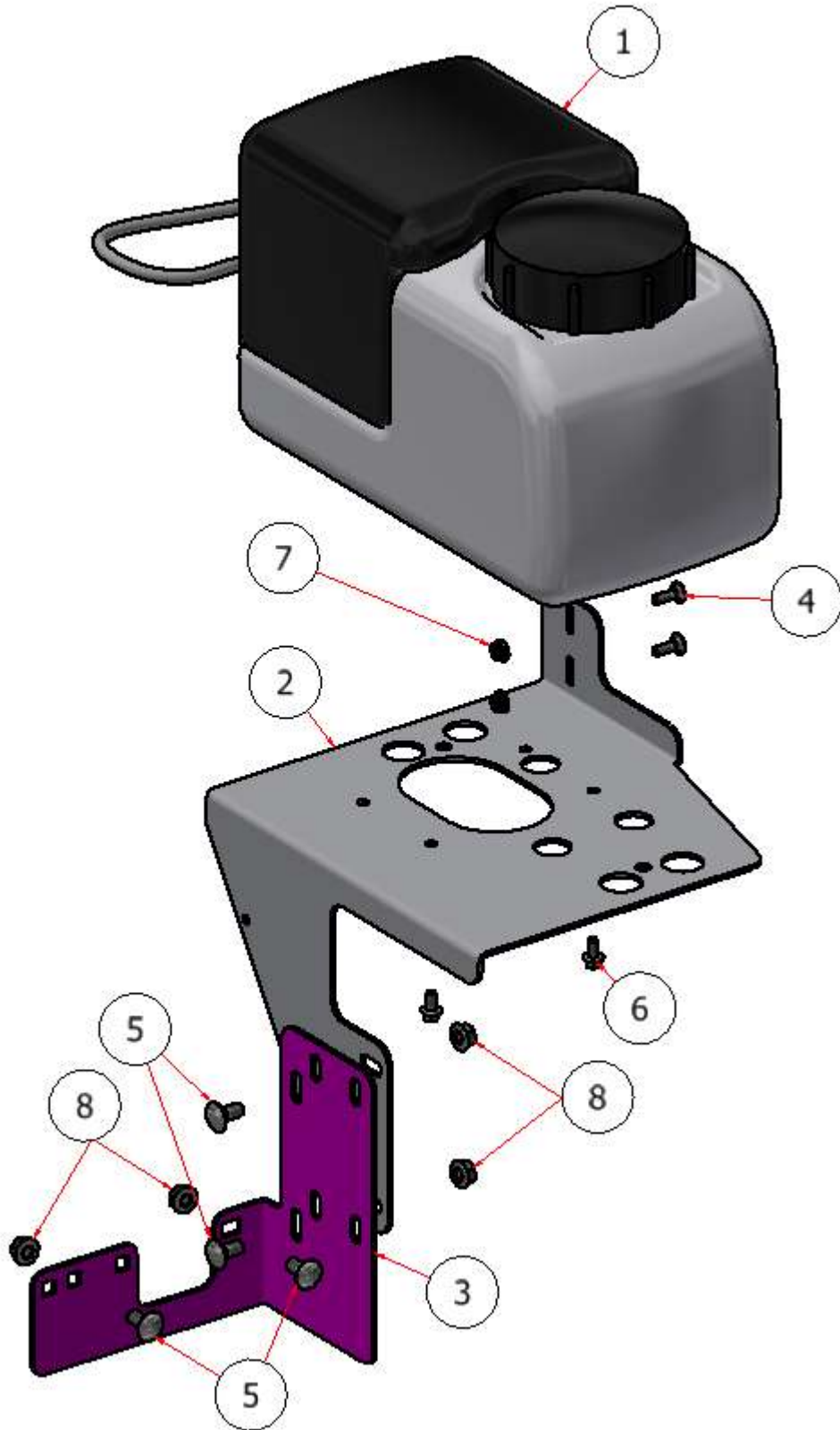

2 GALLON FOAM MARKER EXPLODED VIEW

2 GALLON FOAM MARKER KIT P10020			
ITEM	QTY	PART NUMBER	DESCRIPTION
1	1	MTD 2020	FOAM MARKER, 2 GALLON
2	1	R22-060	SUPPORT BRACKET, FOAM MARKER
3	1	R22-112	SUPPORT BRACKET, LOWER, FOAM MARKER
4	2	CB-1434	CARRIAGE BOLT, 1/4 X 3/4
5	4	CB-3834SS	CARRIAGE BOLT, SS - 3/8-16 x 3/4
6	2	HFSSC-145	HEX FLANGE BOLT, SS - 1/4-20 x 1/2
7	2	HFNCS-14SS	HEX FLANGE NUT, 1/4-20
8	4	HFNCS-38S	HEX FLANGE NUT, SS - 3/8-16

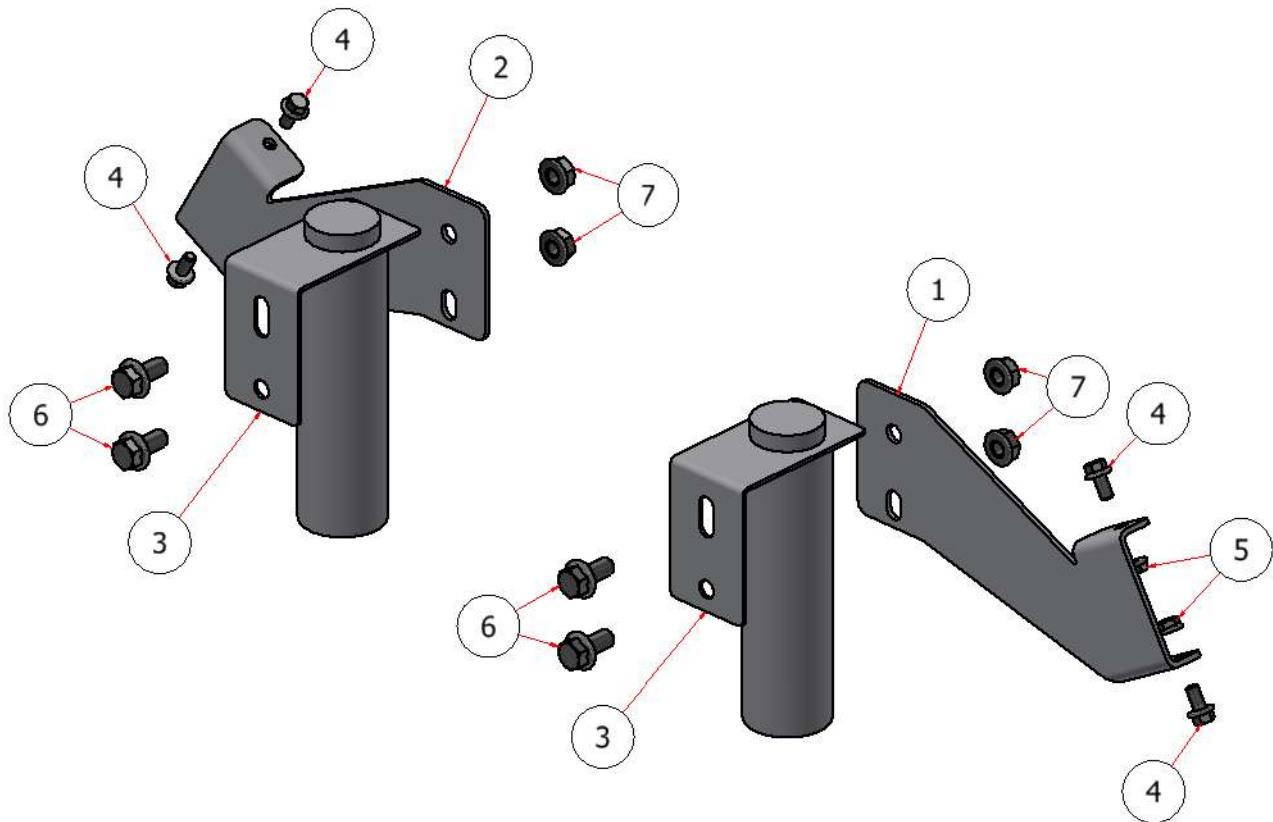

DROPPER ASSEMBLY			
ITEM	QTY	PART NUMBER	DESCRIPTION
1	1	R22-058	BOOM BRACKET, 2 GALLON DROPPER, RIGHT
2	1	R22-058-L	BOOM BRACKET, 2 GALLON DROPPER. LEFT
3	2	X31109	ASSY.,FOAM MARKER DROPPER, 2 GALLON
4	4	HFSSC-145	HEX FLANGE BOLT, SS - 1/4-20 x 1/2
5	4	HFNCS-14SS	HEX FLANGE NUT, 1/4-20
6	4	HFSSC-3875	HEX BOLT, 3/8 X 3/4
7	4	HFNCS-38S	HEX FLANGE NUT, SS - 3/8-16

2 GAL. FOAM MARKER ASSEMBLY INSTRUCTIONS

STEP ONE: Disconnect the battery, *ground* first and then *power* wire.



GROUND

POWER

STEP TWO: Disconnect and remove the fuel tank.

CAUTION!

-Beware of excess fuel in the lines.

-Fuel spillage.

WARNING!

-Flammable gas.

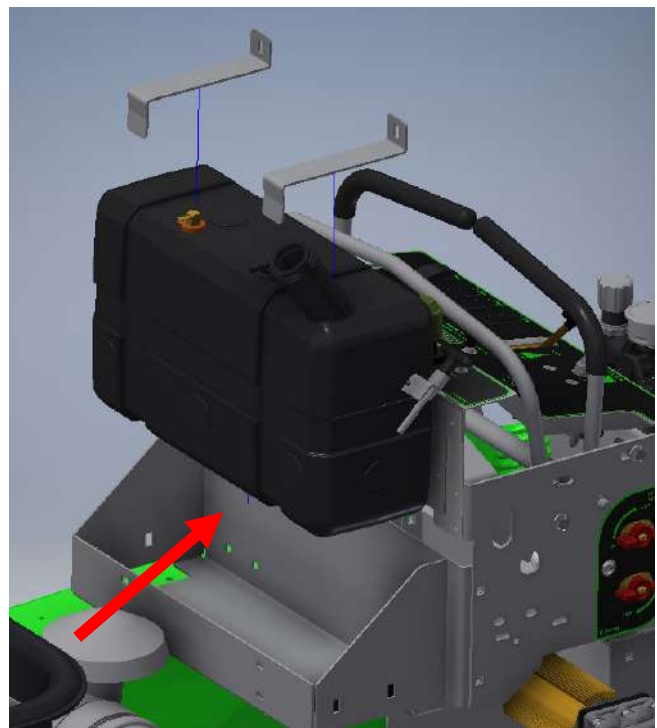

2 GAL. FOAM MARKER ASSEMBLY INSTRUCTIONS

NOTE: Parts are shown in colors for clarity.

STEP THREE:

- Attach the foam marker support bracket (supplied with the kit) to fuel tank support. 2 CB-1434SS and 2 HFNC3-38S (supplied with the kit). Leave the bolts loose.

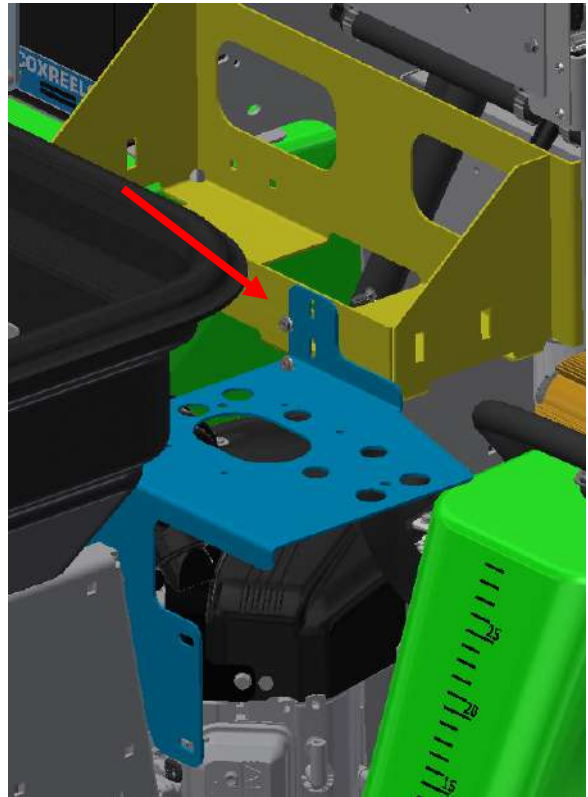

- Attach the lower support bracket (supplied with the kit) to foam marker support bracket and the side of the hopper. 4 CB-1434SS and 4 HFNC3-38S (supplied with the kit).
- Once all the bolts are started, they can be tighten.

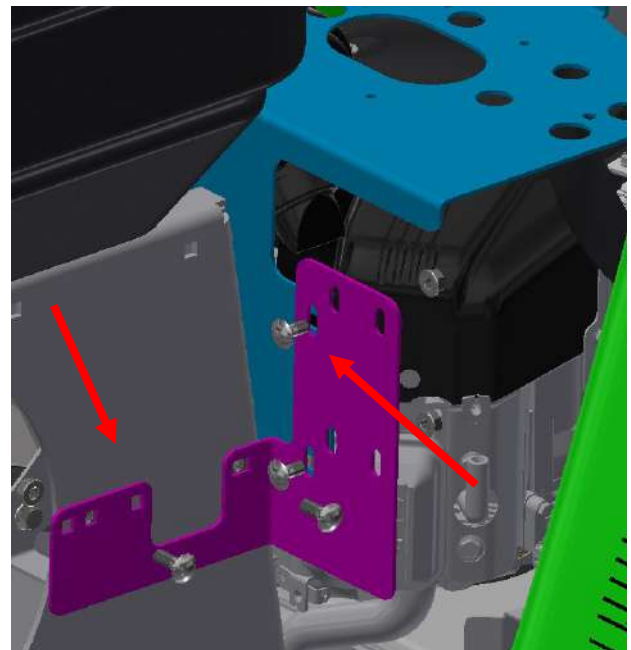

2 GAL. FOAM MARKER ASSEMBLY INSTRUCTIONS

- Attach the foam marker assembly (supplied with the kit) to the support.
Use 2 HFSSC-381 (supplied with the kit).

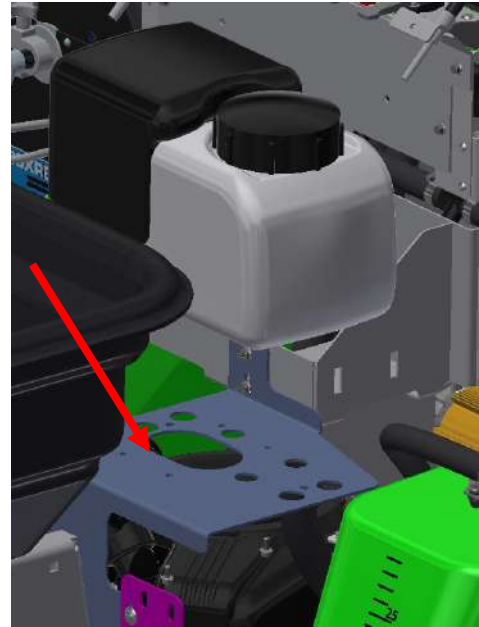

STEP FOUR: Attach the foam marker bracket to the end of the boom.

NOTE: Repeat step four for the other side of the boom, and the orientation of the bracket for left and right side.

RIGHT SIDE

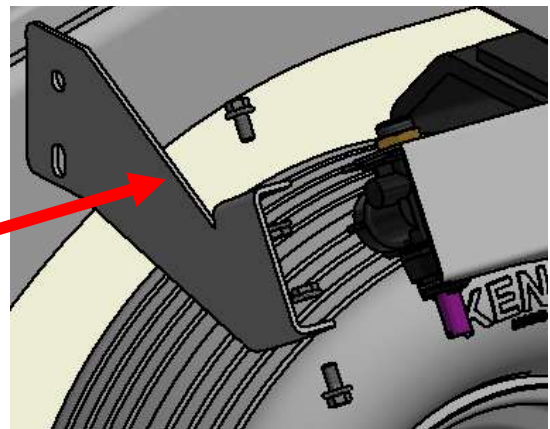

STEP FIVE: Attach the foam marker assembly to the bracket.

NOTE: Repeat step five for the other side of the boom.

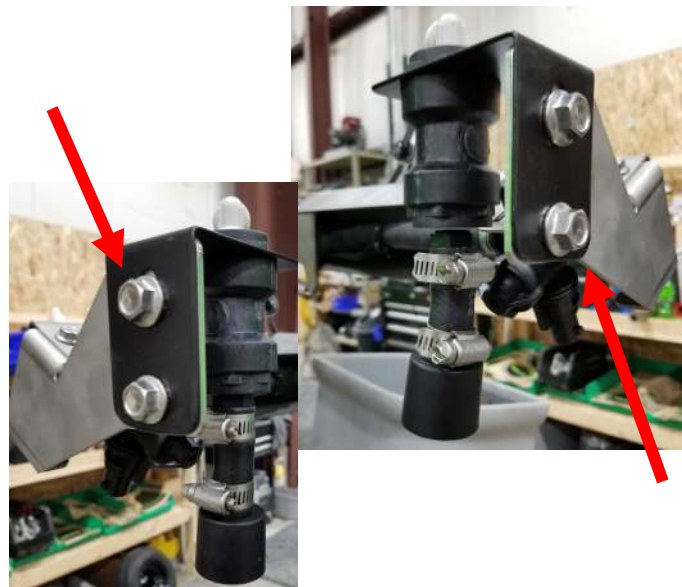

2 GAL. FOAM MARKER ASSEMBLY INSTRUCTIONS

STEP SIX:

- Remove the plastic cap from “aux 3” in the panel and route the wiring harness down through the hole in the dash panel.
- Attach the “rocker switch” to the dash panel.

NOTE:

- *The long side of the rocker switch should face down.*
- *Remove ‘L’ bracket from the harness before installation.*



STEP SEVEN: Continue to route the wiring harness down through the uprights attaching it with zip ties as necessary.



2 GAL. FOAM MARKER ASSEMBLY INSTRUCTIONS

STEP EIGHT:

- Connect the ground wire from the wiring harness to the up right cross member.
- Route the power wire neatly down and along the frame to the battery.

NOTE: Do not connect the *Power wire* until all connections are made, (see step ten)



STEP NINE: Plug the pump power connector from the harness to the foam marker power connector.



2 GAL. FOAM MARKER ASSEMBLY INSTRUCTIONS

STEP TEN:

- Reconnect the battery *power wire* first along with the *yellow power wire* from the wiring harness, and then reconnect the *ground wire*.



GROUND

POWER

- Reinstall and connect the fuel tank.

CAUTION!

-Beware of excess fuel in the lines.

-Fuel spillage.

WARNING!

-Flammable gas.

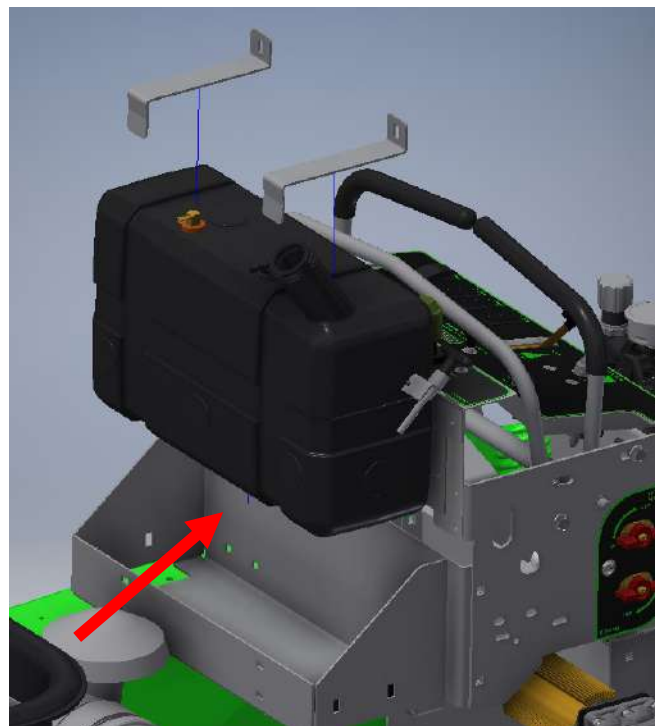

2 GAL. INDEPENDENT SPRAYER ASSEMBLY INSTRUCTIONS

STEP ELEVEN:

- Connect the “y” adapter assembly to the *push lock elbow fitting* on the foam marker.
- Using the supplied tubing and hose wrap, cut and route the tubing from the “y” adapter along the frame and up to the foam marker. *Be sure to leave enough tubing for the boom to extend, fig. one.*



Fig. One

- Connect the tubing to the foam marker, the top is air and the bottom is liquid *for both left and right side.*

NOTE: Repeat step eleven for the other side of the boom.

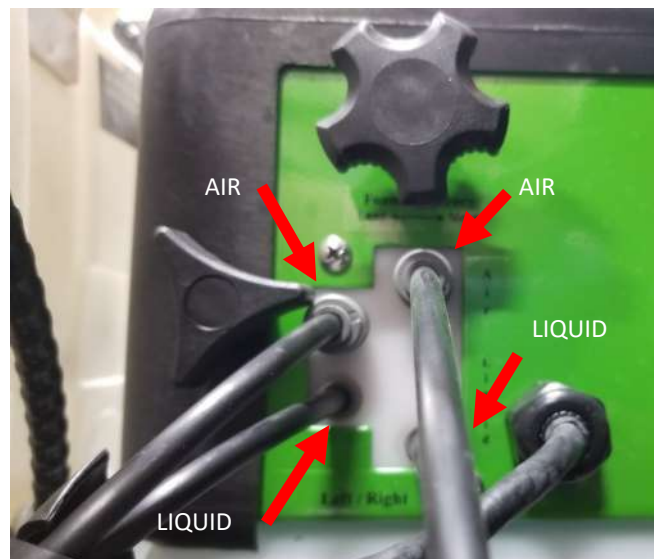

2 GAL. INDEPENDENT SPRAYER ASSEMBLY INSTRUCTIONS

OPERATION

FILLING THE TANK

CAUTION!

- *Wear safety goggles & all proper clothing when operating, servicing or refilling this machine.*
 - *Always read & follow manufactures recommendations when handling any chemical.*
 - *Do not pump combustible liquids or vapors with this product.*
 - *When filling the tank, add WATER FIRST and then FOAMING AGENT.*
- Be sure the power is off and remove the cap from the top of the tank.
 - Starting with a small amount of water (2 gal.), mix the foam concentrate according to the label directions on the foaming agent. If considerably more concentrate is needed above the manufacturer's suggested ratio (usually 2-5 ounces per gallon) to produce good foam, use of a softener or soft water may be required. If the foam is too stiff or (dry), it may surge out at irregular intervals. Under this condition. Add water until the foam becomes more wet.
 - Replace the cap on the tank.

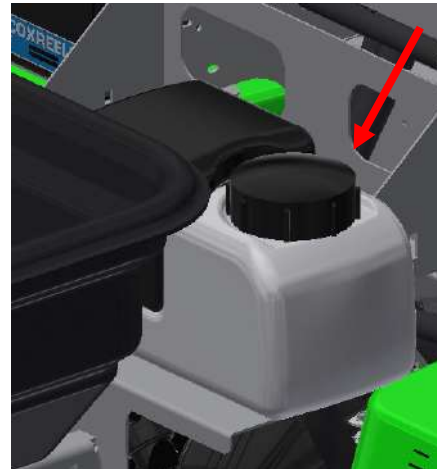

NOTE: *Mixing foam takes some experience. Different water sources may require different amounts of concentrate to obtain the desired foam density. Water hardness, pH, and impurities will affect the rate of concentrate required for a consistent, long-lasting foam.*

Different conditions may require different mixing ratios to produce desirable results. It's worthwhile to determine the proper foam/water mixing ratio for your water source with the initial filling. Doing so will save time in the future and aid in consistent foam quality.

If hard water is a problem, commercial softening agents are available. You can make your own softening agent by dissolving a commercial water softening powder (available at most grocery stores) in hot water and adding a portion of the mixture to your tank each time you fill. Experimentation will reveal the correct amount to use. A good starting point is 1-1/2 ounces per gallon of water.

Mix ratios for foam concentrates advertised as 80:1 or 160:1 must be adjusted for use with your water. Such ratios are only a guideline.

Heat, humidity, & wind will also affect the life of the foam. Using a good quality marking agent, such as RUNWAY, may be very important. Liquid dish detergent also works in the foam marker system. You will have to experiment with detergents before using on any special turf applications.

2 GAL. INDEPENDENT SPRAYER ASSEMBLY INSTRUCTIONS

- Start the machine and activate the foam marker and let it prime until it starts dropping suds.

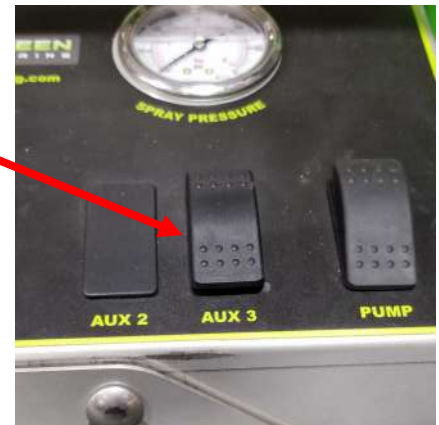

- Turn the foam marker and machine off, Adjust the foam marker for desired timing.

A - Flow control valve,

- Rotate the knob clockwise to *decrease* foam output.
- Rotate the knob counter-clockwise to *increase* foam output.



2 GAL. INDEPENDENT SPRAYER ASSEMBLY INSTRUCTIONS

TROUBLE SHOOTING

PROBLEM	SOLUTION
NOT ENOUGH FOAM	<ul style="list-style-type: none">• ADD MORE FOAM CONCENTRATE TO THE TANK.• CHECK FOR HOLES IN THE AIR LINE.• CHECK FOR PINCHED AIR OR LIQUID LINES.• CLEAN SCREEN-STRAINER/FOAM HEAD.
WET FOAM	<ul style="list-style-type: none">• ADD MORE FOAM CONCENTRATE TO THE TANK.• CLEAN SCREEN-STRAINER/FOAM HEAD.
FOAM IS SURGING	USE LESS CONCENTRATE.
FOAM DOES NOT LAST LONG ON THE GROUND	<ul style="list-style-type: none">• ADD MORE FOAM CONCENTRATE TO THE TANK.• USE A HIGH QUALITY FOAM CONCENTRATE LIKE RUNWAY.
BLOWING FOAM IN WENDY WEATHER	<ul style="list-style-type: none">• USE LESS CONCENTRATE TO MAKE WETTER FOAM.• ADD MORE WATER TO FOAM SOLUTION



Steel Green Mfg.
824 S State Road 39
Lebanon, IN 46052
(765)-481-2890
www.steelgreenmfg.com

MANUAL PART NO.	MANUAL REV.	DESCRIPTION	KIT PART NO.
SGM-002	B	2 GALLON FOAM MARKER SG 46/52 KIT	P10020