



INSTRUCTION MANUAL

25 GALLON TANK OPTION

Models: SG46



SG46 25 GALLON TANK INSTALL

25 GALLON TANK KIT K10017							
ITEM	PART NUMBER	QTY.	DESCRIPTION	ITEM	PART NUMBER	QTY.	DESCRIPTION
PREASSEMBLED RIGHT SIDE				13	R21-175	1	FRONT TANK SUPPORT LEFT
1	M10025	1	25 GALLON TANK RIGHT	14	R21-175-R	1	FRONT TANK SUPPORT RIGHT
2	S51242	3	BULKHEAD FITTING	15	R21-176	1	REAR TANK SUPPORT RIGHT
3	S52081	1	3/4" PIPE PLUG	16	R21-176-L	1	REAR TANK SUPPORT LEFT
4	S52029	2	3/4" NPT X 3/4 BARB 90 ELBOW	17	R21-177	1	MOUNTING BRACKET, HOSE REEL
5	S51243	1	TANK LID	18	R21-067	1	MOUNTING PLATE, HOSE REEL
6	R21-113	1	ANTI VORTEX PLATE	19	R21-208	1	ANTI VIBRATION BRACKET
PREASSEMBLED LEFT SIDE				20	HFSSC-3875	12	3/8" X 3/4" HEX BOLT
7	M10025	1	25 GALLON TANK LEFT	21	HFSSC-1434	4	1/4" X 3/4" HEX BOLT
8	S51242	3	BULKHEAD FITTING	22	HFSSC-145	2	1/4" X 1/2" HEX BOLT
9	S52081	1	3/4" PIPE PLUG	23	CB-381SS	6	3/8" X 1" CARRIAGE BOLT
10	S52029	2	3/4" NPT X 3/4 BARB 90 ELBOW	24	CB-3834SS	8	3/8" X 3/4" CARRIAGE BOLT
11	S51243	1	TANK LID	25	HFNCS-38	12	3/8" HEX NUT
12	R21-113	1	ANTI VORTEX PLATE	26	12HS	4	3/4" HOSE CLAMP

NOTE: Repeat the instructions in this manual for the left and right side of the machine.

STEP ONE: Support the machine with a jack or lift and remove the rear tire.

WARNING!

Use proper jack stands to safely support the machine before attempting to sit or lay under the machine.

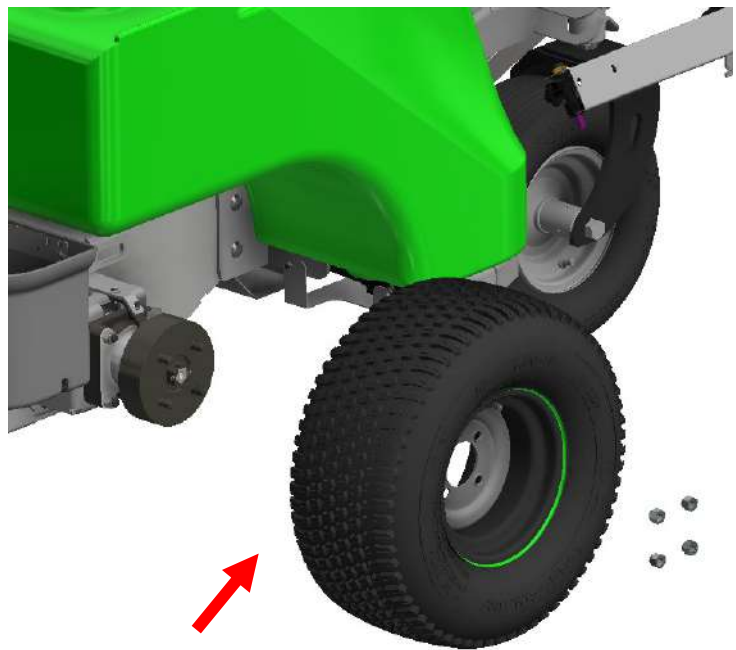

SG46 25 GALLON TANK INSTALL

CAUTION!

Before continuing with the following steps, be sure All liquid tanks are drained.

STEP TWO: Remove the protective shield from bottom of the tank support (1/4" bolts).

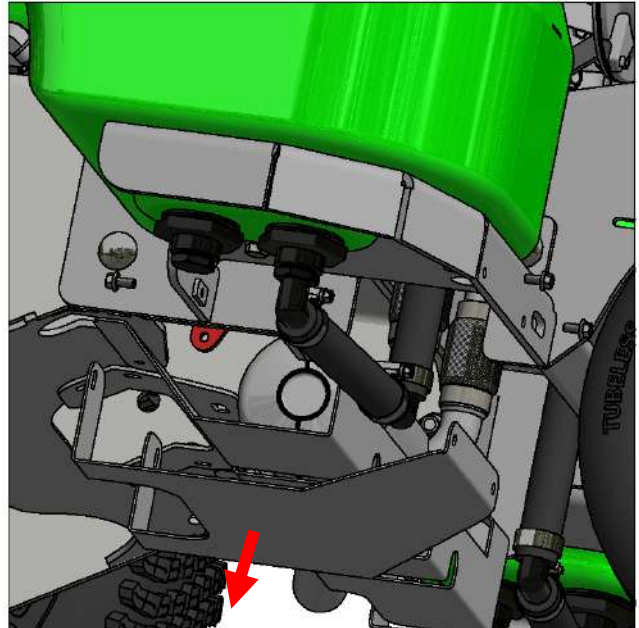

NOTE: *Before disconnecting the hoses place a drip pan under it to catch any excess fluid.*

STEP THREE: Loosen the hose clamp and disconnect the suction hose.

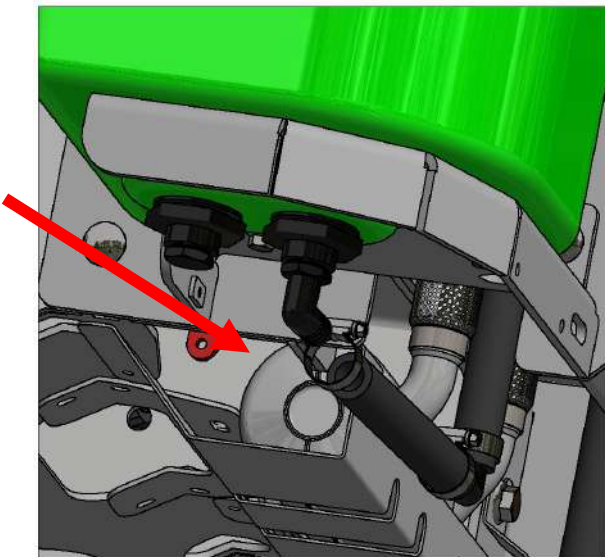

STEP FOUR: Loosen the hose clamp and disconnect the return hose.

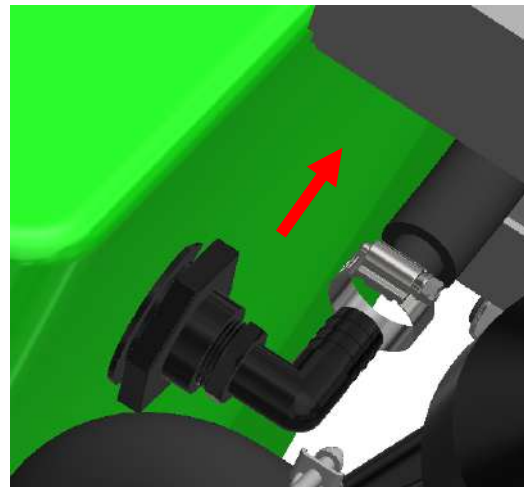

SG46 25 GALLON TANK INSTALL

STEP Five: Remove the fert tray from the rear tank support.

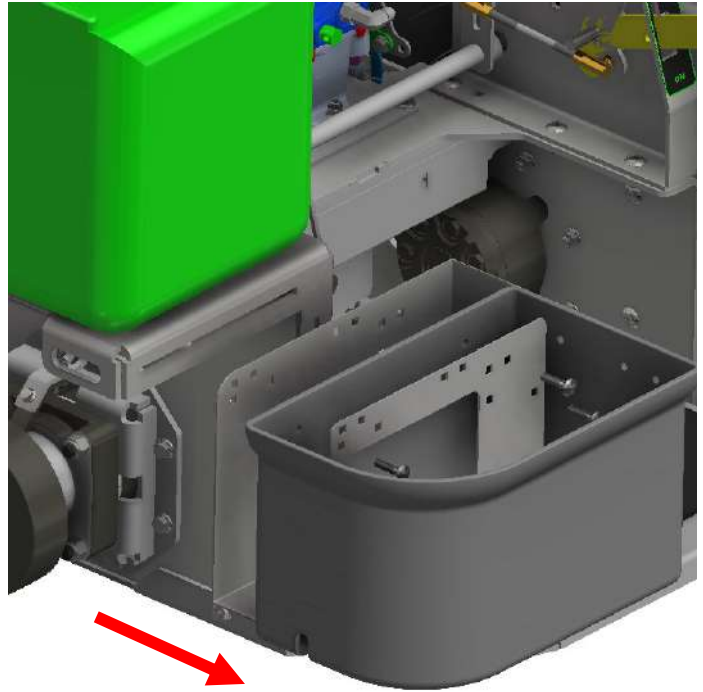

NOTE: *If equipped with 7 gallon option, remove the system from the rear tank support.*

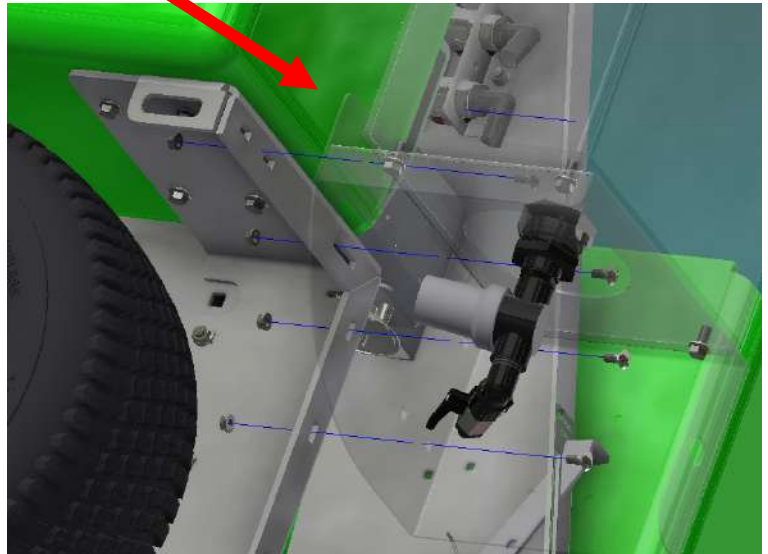

SG46 25 GALLON TANK INSTALL

STEP SIX: Remove the hose reel assembly from the tank.

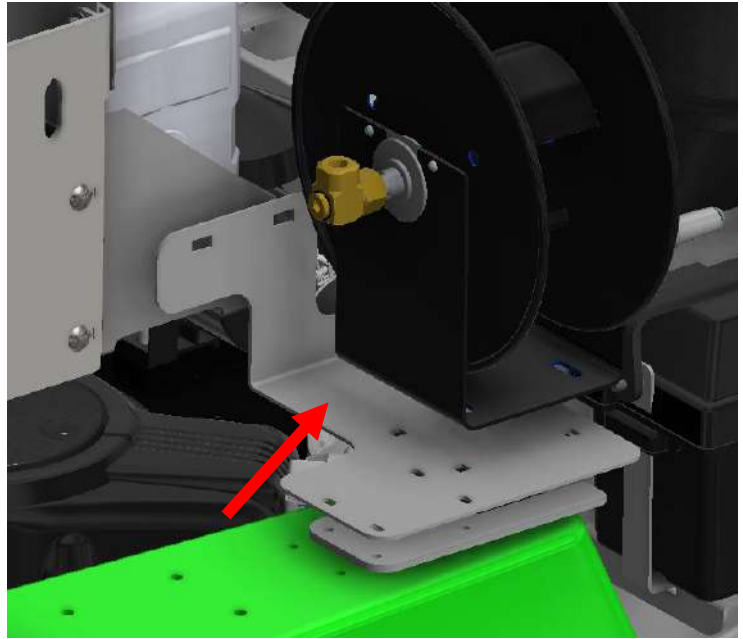

STEP SEVEN: Remove the spray pump from the left tank.

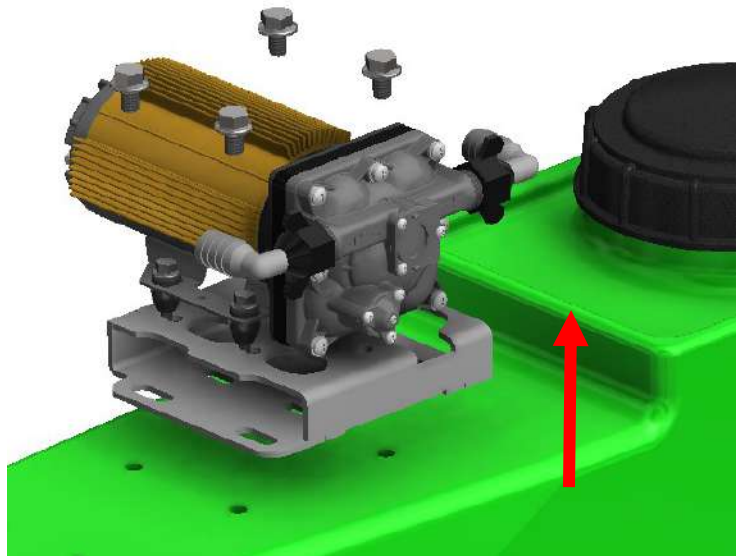

SG46 25 GALLON TANK INSTALL

STEP EIGHT: Loosen the 6 bolts securing the tank and remove the tank from the frame.

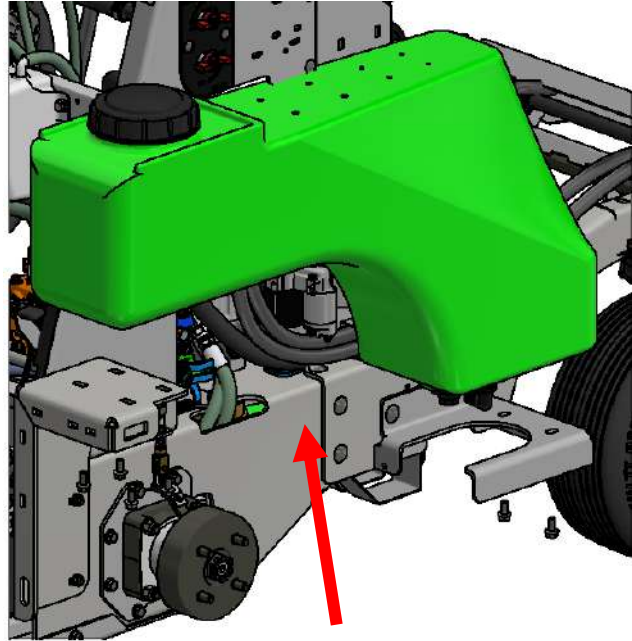

STEP NINE: Remove the tank supports from the frame.

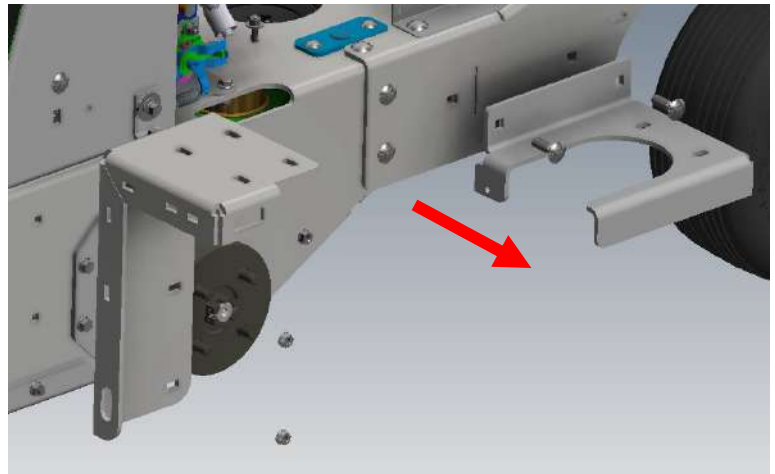

STEP TEN: Attach the brackets supplied with the kit to the frame.

NOTE: Leave the rear supports loose on both sides.

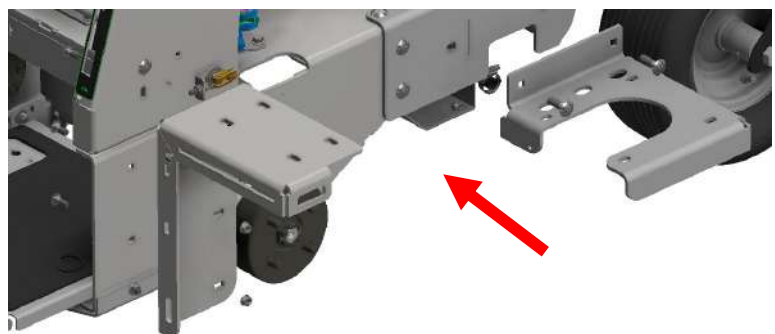

SG46 25 GALLON TANK INSTALL

STEP ELEVEN:

- (Fig 1) Rest the right side" tank assembly (supplied with the kit) on the tank supports.
- (Fig 2) Starting with the front support, align and attach the tank using 4 hex bolts (HFSSC-3875 supplied with the kit). *Leave the bolts loose.*
- (Fig 2) Align the tank with the rear support and attach the rear of the tank with 4 hex bolts (HFNCS-3875 supplied with the kit). *Leave the bolts loose.*
- (Fig 2) Once all the bolts have been started, start with the rear tank support and tighten it to the frame while pulling back on it.
- (Fig 2) Tighten the 4 bolts securing the tank to the rear support.
- (Fig 2) Working forward, tighten the 4 bolts securing the tank to the front support.

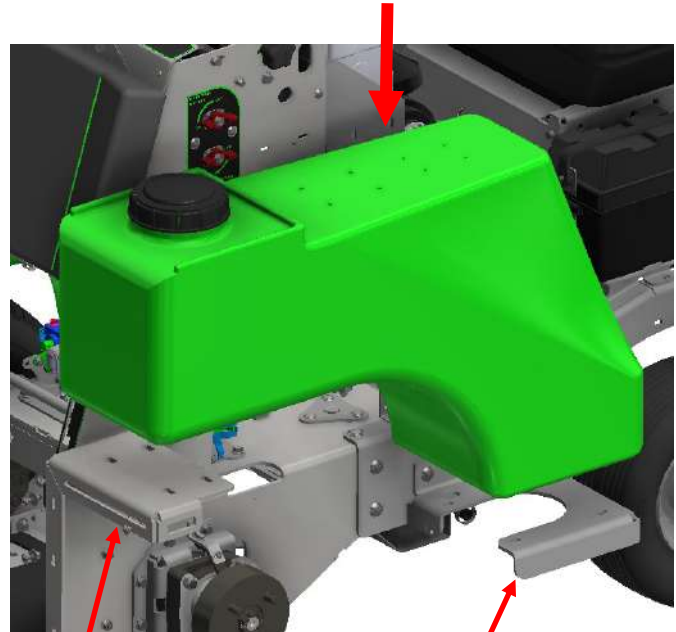
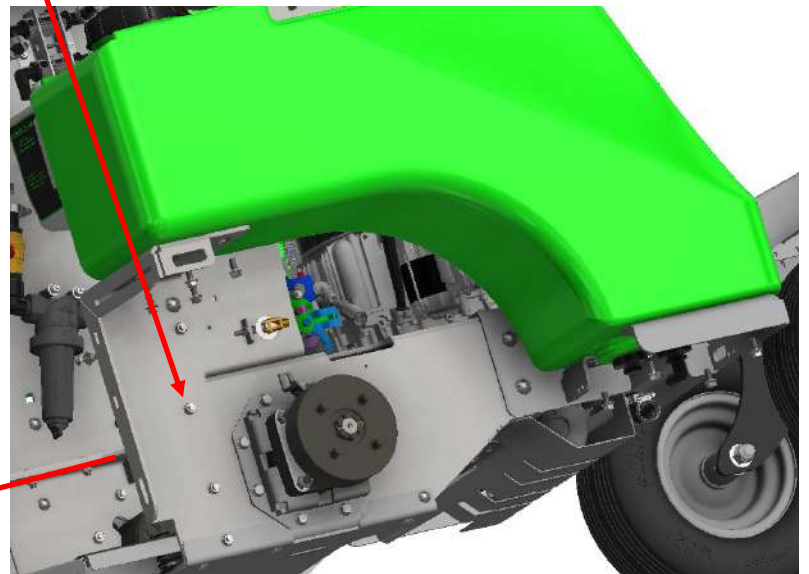

Fig 1

REAR TANK SUPPORT

FRONT TANK SUPPORT



PULL BACK

Fig 2

SG46 25 GALLON TANK INSTALL

NOTE: *The fuel tank will have to be removed or shifted to allow the 2 CB-3834SS carriage bolts to be installed. Leave the fuel tank removed until the hose reel is attached to the right side tank (step twelve)*

- (Fig 3) Attach the anti vibration bracket (supplied with the kit R21-208) to the “right side tank” using (2) CB-3834SS, (2) HFNCS-38, and (2) HFSSC-145(also supplied with the kit).

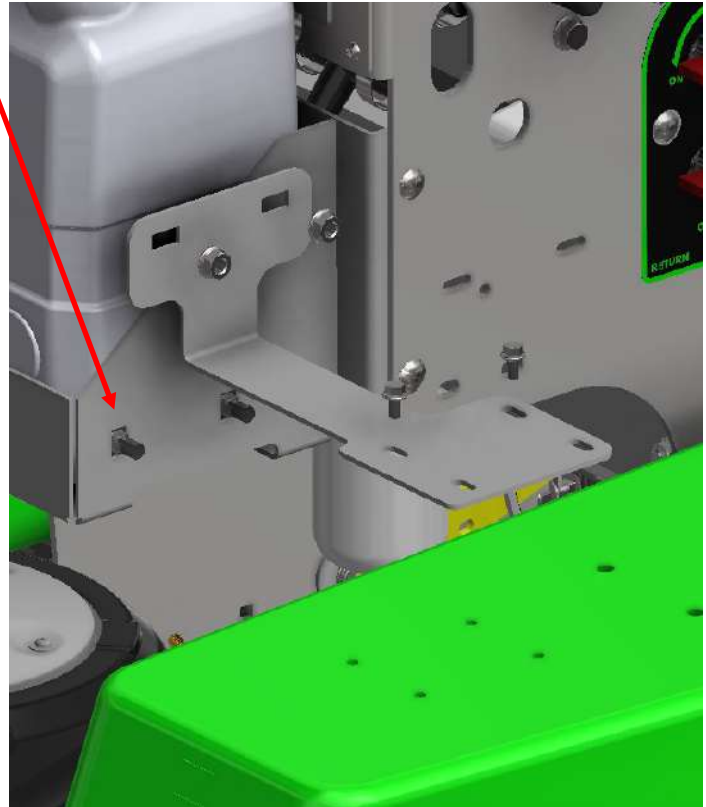

Fig 3

SG46 25 GALLON TANK INSTALL

STEP TWELVE: Reattach the hose reel to the right tank using the plate and bracket (supplied with the kit).

HFNCS-38 (6)

HFSSC-1434 (4)

CB-3834SS (6)

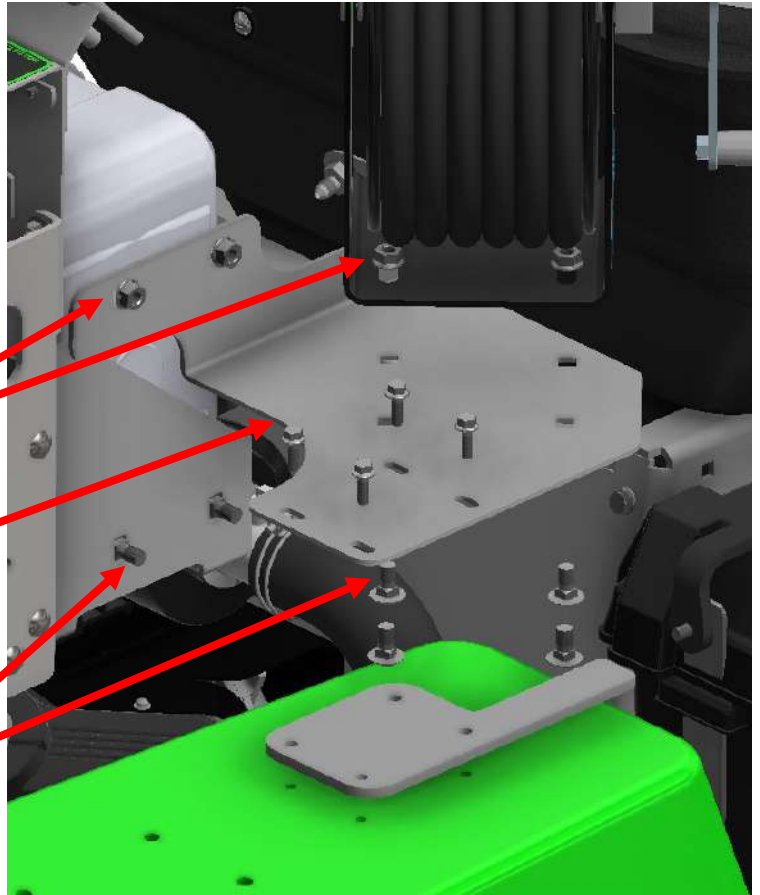

NOTE: *The fuel tank will have to be removed or shifted to allow the 2 CB-3834SS carriage bolts to be installed.*

STEP THIRTEEN: Reconnect the return hose to the return fitting on the tank, securing it with the hose clamp.

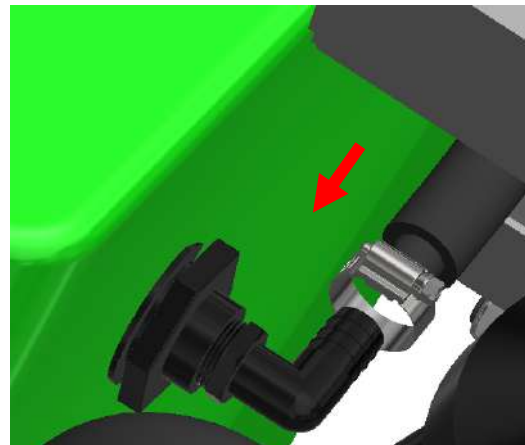

SG46 25 GALLON TANK INSTALL

STEP FOURTEEN:

- Reconnect the suction hose to the suction fitting and secure it with a hose clamp.

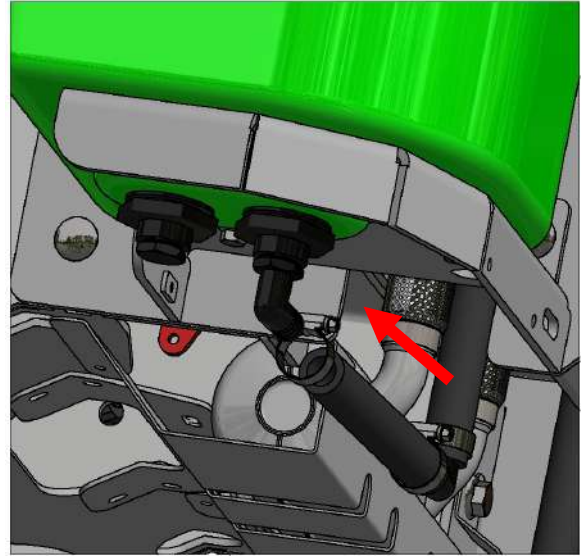

- Reattach the safety shield to the front support.

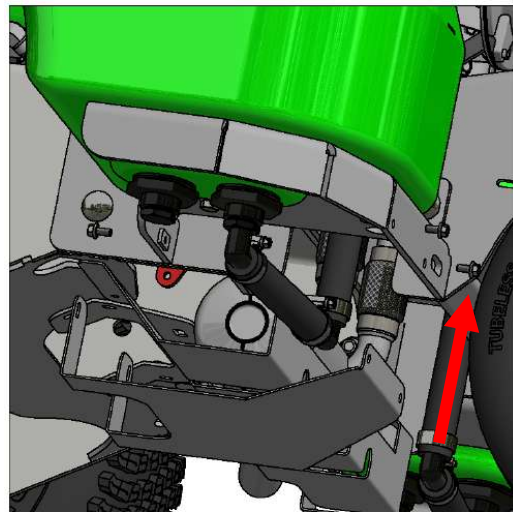

STEP FIFTEEN: Reattach the spray pump to the left tank.

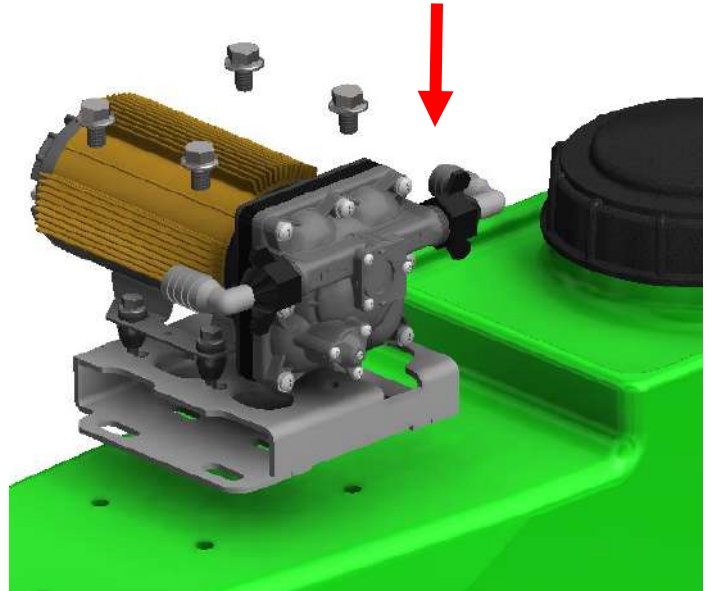

SG46 25 GALLON TANK INSTALL

STEP SIXTEEN: Reattach the fert tray to the rear tank support.

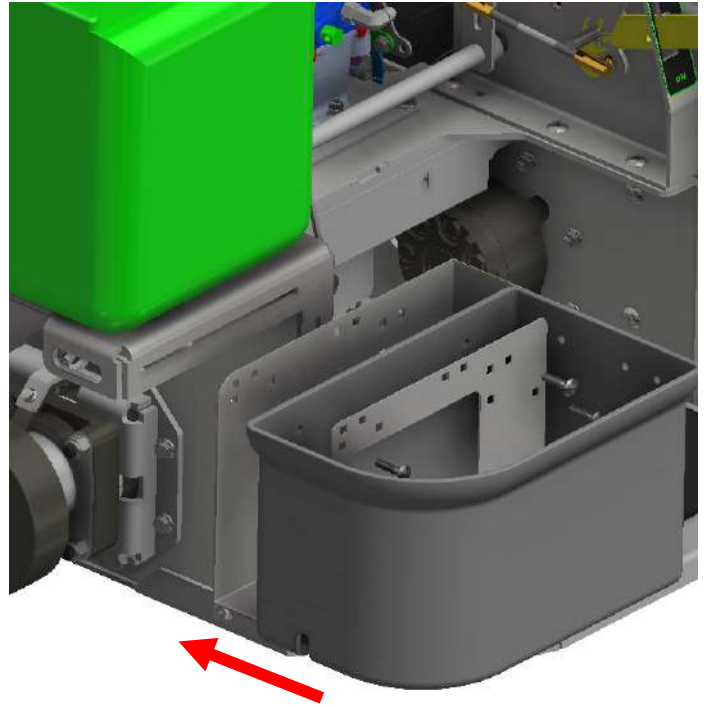

STEP SEVENTEEN: Reattach the rear tires.

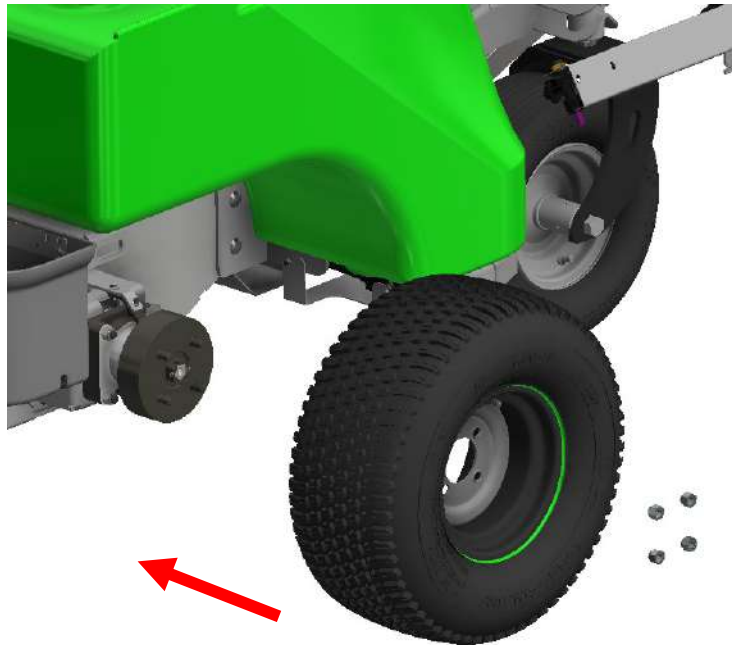



Steel Green Mfg.
824 S State Road 39
Lebanon, IN 46052
(765)-481-2890
www.steelgreenmfg.com

MANUAL PART NO.	MANUAL REV.	DESCRIPTION	KIT PART NO.
SGM-006	B	25 GALLON OPTION, SG46	K10017