

INSTRUCTION MANUAL

35 GALLON TANK ATTACHMENT

Models: SG46, & SG52

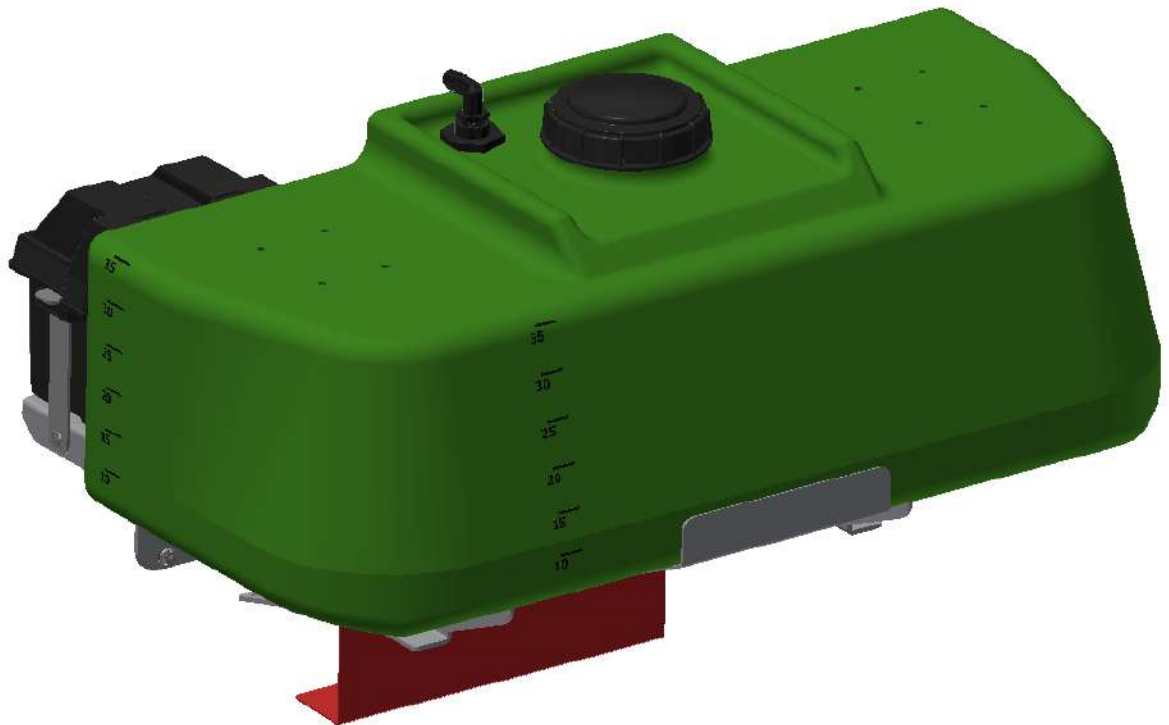

35 GALLON INSTALL INSTRUCTIONS

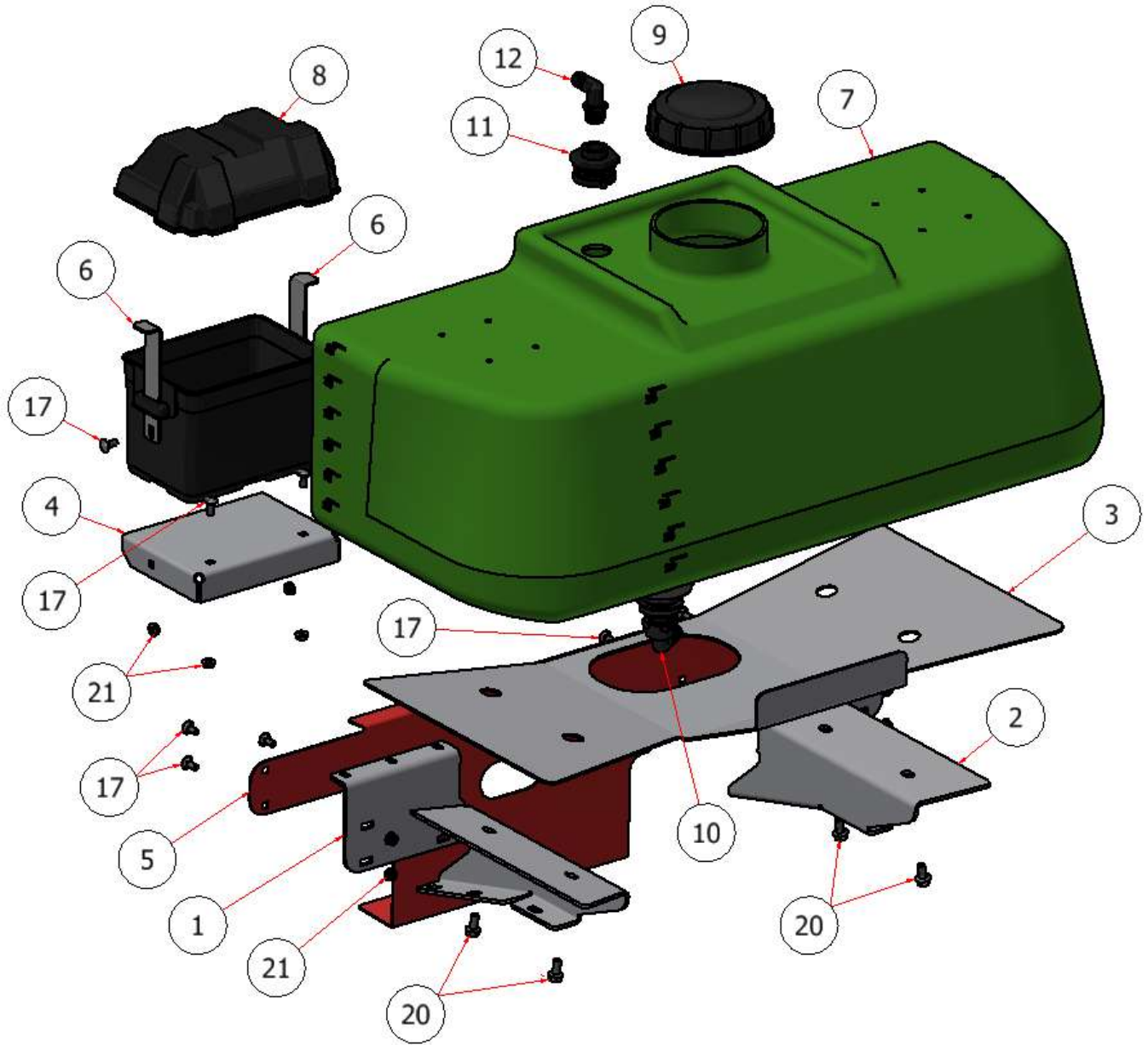

35 GALLON INSTALL INSTRUCTIONS

PARTS LIST			
ITEM	QTY	PART NUMBER	DESCRIPTION
1	1	R22-150-01	TANK SUPPORT BRACKET, 35 GAL., RIGHT
2	1	R22-150_MIR	TANK SUPPORT BRACKET, 35 GAL., LEFT
3	1	R22-151	TANK PLATE, 35 GAL.
4	1	R22-152	BATTERY BOX SUPPORT, 35 GAL.
5	1	R22-160-01	FERT SHIELD, 35 GAL.
6	2	R21-214	BRACKET, BATTERY BOX
7	1	M10035-A	TANK, 35 GALLON
8	2	E40002	BATTERY BOX
9	1	S51243	CAP, TANK
10	1	S52200	KIT, BULKHEAD, 3/4
11	1	S51242	BULKHEAD FITTING, TANK
12	1	S52029	BARB, 3/4 MPT x 3/4 BARB 90
13	1	W21-100	MOUNTING BRACKET, SPRAY PUMP
14	1	S54000	PUMP, SHURFLO
15	1	S54120	HEAT SINK, SPRAY PUMP
16	2	S54102	PUMP FITTING, BARB, ELBOW, 1/2 X 3/4
17	10	CB-51634	CARRIAGE BOLT, SS - 5/16-18 x 3/4
18	4	HFSSC-141	HEX FLANGE BOLT, 1/4 X 1
19	4	HFSSC-3812	HEX FLANGE BOLT, 3/8 X 1/2
20	4	HFSSC-3875	HEX BOLT, 3/8 X 3/4
21	10	HFNCS-516S	HEX NUT 5/16

35 GALLON INSTALL INSTRUCTIONS

STEP ONE:

- Disconnect the battery, *ground* first and then *power* wire.
- Remove the battery from the battery box.



GROUND

POWER

STEP TWO: Disconnect the hoses from the hopper and connect them to the circulation fitting.

NOTE: Hold the hoses up to prevent oil spillage



35 GALLON INSTALL INSTRUCTIONS

STEP THREE: Disconnect the cables from the dash.

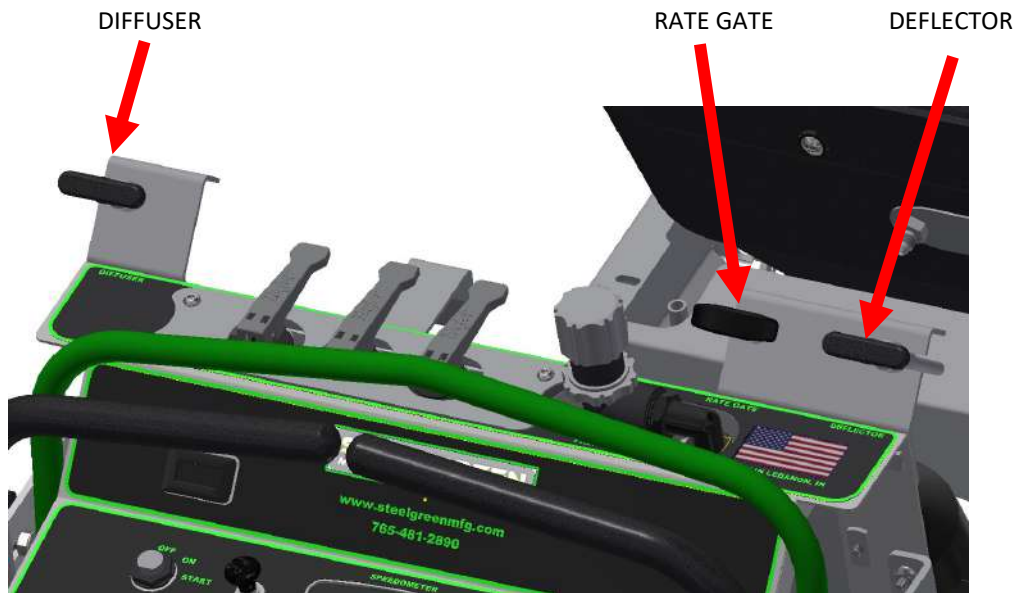

NOTE: *Be sure the hopper is empty before proceeding.*

STEP FOUR: Remove the six bolts that hold the hopper assembly to the frame and lift the hopper assembly from the frame.

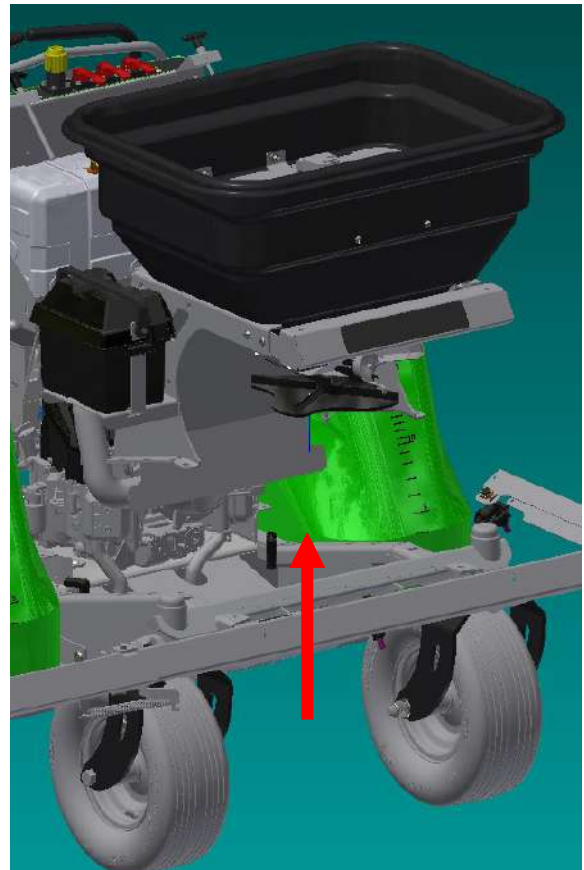

35 GALLON INSTALL INSTRUCTIONS

STEP FIVE:

- Set the 35 gallon tank assembly on the frame.
- Attach it to the frame with the six bolts.



35 GALLON INSTALL INSTRUCTIONS

VALVE ASSEMBLY



VALVE ASSEMBLY W/FOAM MARKER

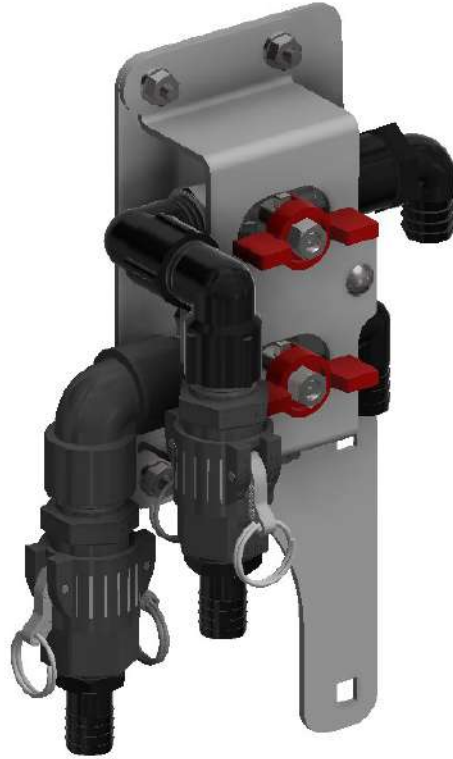

STEP SIX: Remove the (2) bolts that secure the gas tank support and Attach the valve assembly to the *left* side of the upright.

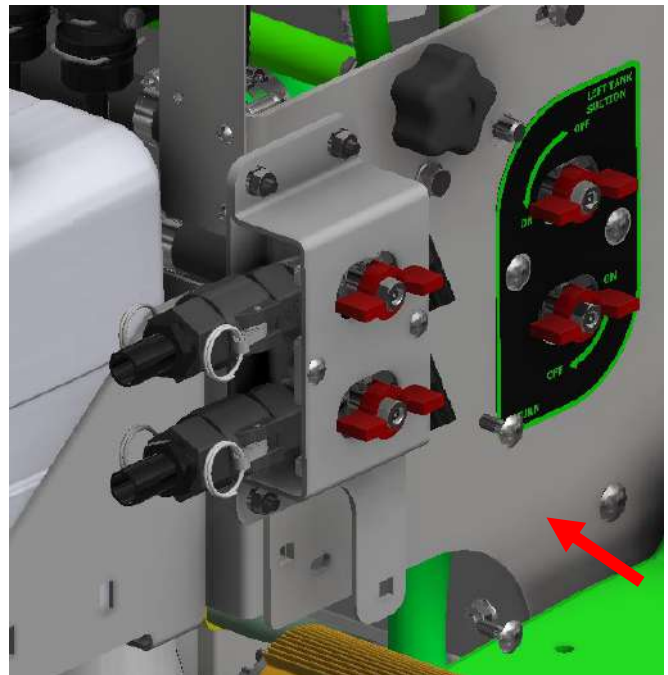

35 GALLON INSTALL INSTRUCTIONS

NOTE:

- Before beginning step seven, BE SURE there is no pressure on the lines and fluid is drained.
- Parts removed for clarity.

STEP SEVEN:

- Remove the knee pad to access the return & suction lines.
- Carefully cut and install the “tee” fittings in the “suction” and “return” lines as shown (blue arrows). Securely fasten with 3/4 hose clamps.

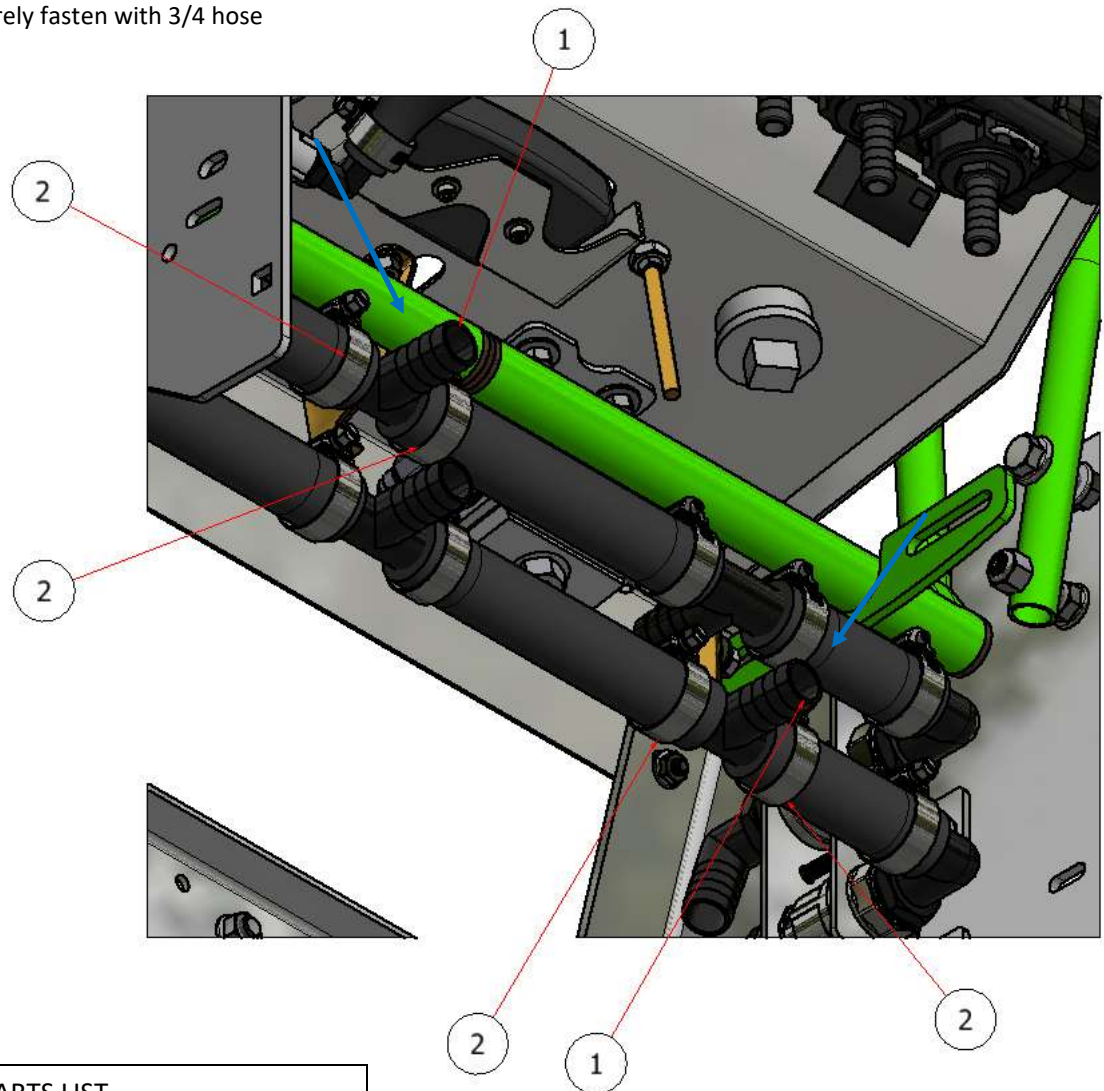

PARTS LIST

ITEM	QTY	PART NUMBER	DESCRIPTION
1	4	12HS	HOSE CLAMP, 3/4
2	2	S50062	TEE FITTING, 3/4 HOSE

35 GALLON INSTALL INSTRUCTIONS

STEP EIGHT:

- Cut and install 3/4" suction hose, connecting one end to the suction fitting on the top valve and the other end to the "tee" fitting in the suction line.
- Cut and install 3/4" return hose, connecting one end to the return fitting on the bottom valve and the other end to the "tee" fitting in the return line.
- Securely fasten each end with 3/4" hose clamp.

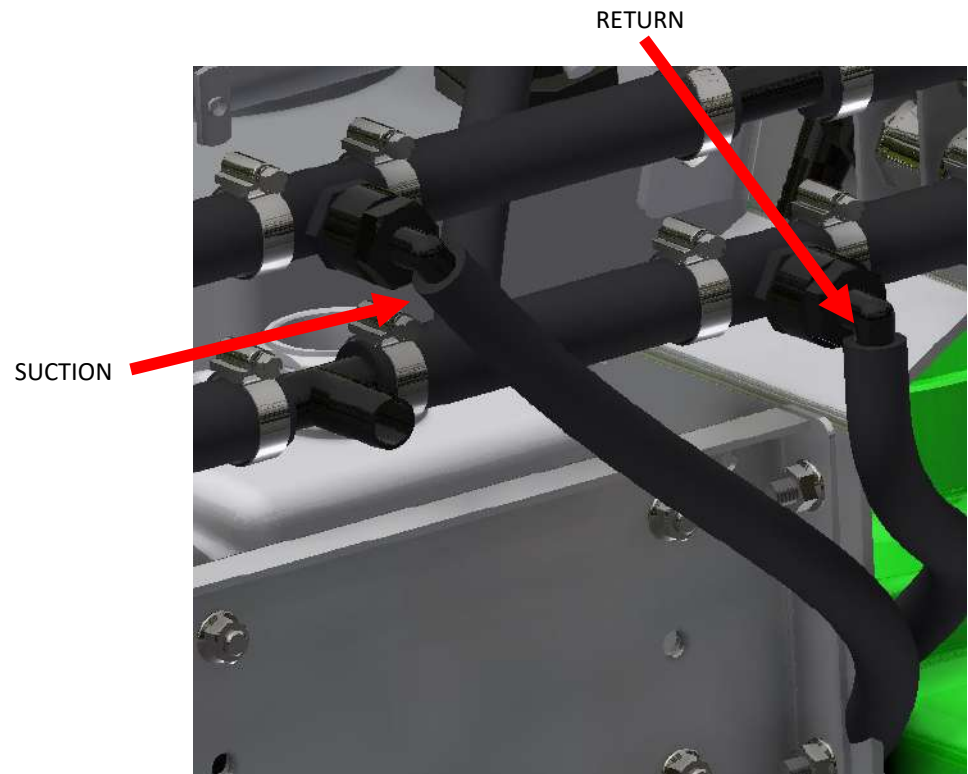
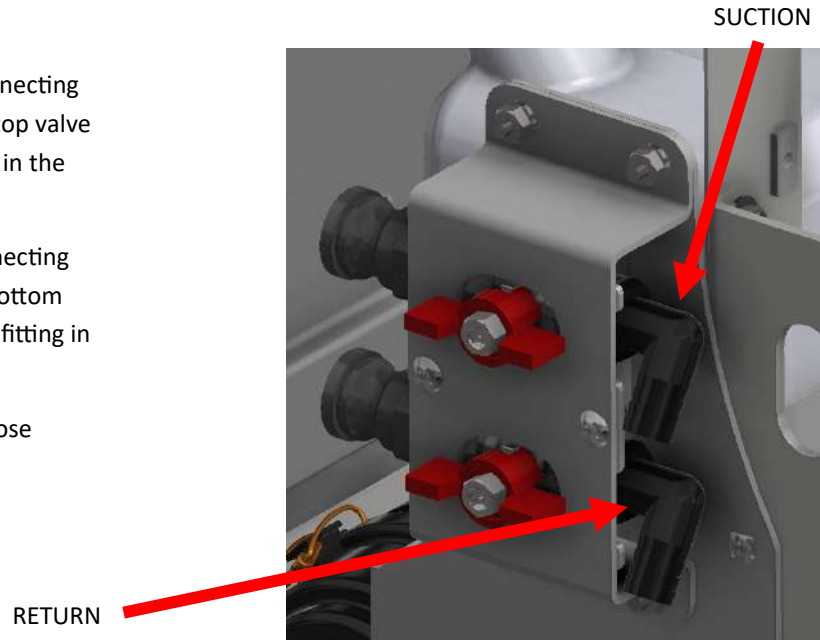

35 GALLON INSTALL INSTRUCTIONS

STEP NINE: Connect the “quick disconnect” hoses from the tank to the valves.

- Top valve is **SUCTION**.
- Bottom valve is **RETURN**.

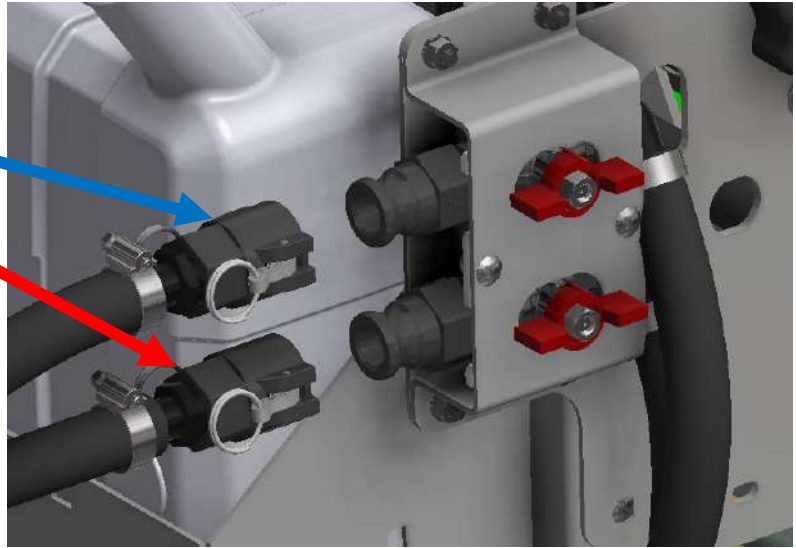

VALVE ASSEMBLY



VALVE ASSEMBLY W/FOAM MARKER

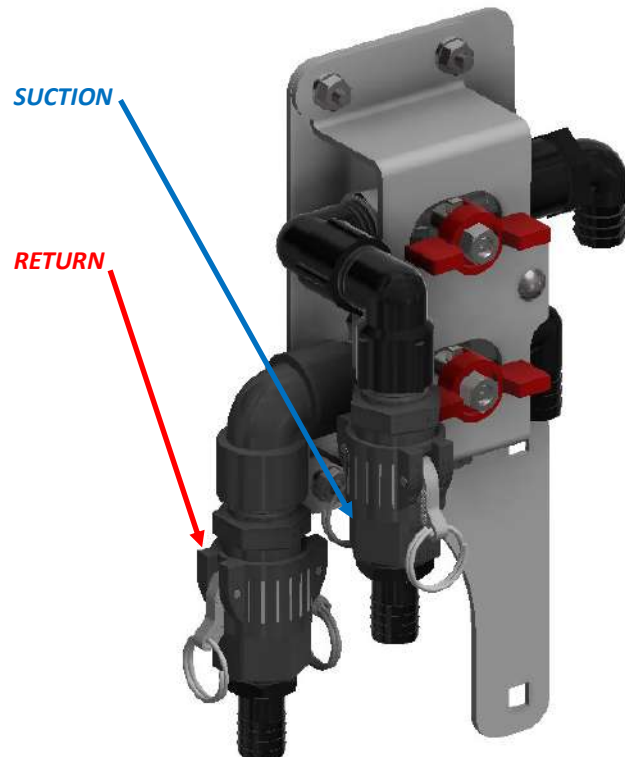

35 GALLON INSTALL INSTRUCTIONS

STEP TEN:

- Set the battery in the battery box.
- Reconnect the battery cables, power cable and wires first followed by the ground wire.
- Attach the battery box cover and bungee strap.



GROUND

POWER



MADE IN THE USA

Steel Green Mfg.
824 S State Road 39
Lebanon, IN 46052
(765)-481-2890
www.steelgreenmfg.com

MANUAL PART NO.	MANUAL REV.	DESCRIPTION	KIT PART NO.
SGM-008	B	35 GALLON TANK ATTACHMENT	