

INSTRUCTION MANUAL

HI-FLOW DOUBLE SPRAY PUMP SWAP

Models: SG36, SG42, SG46, & SG52

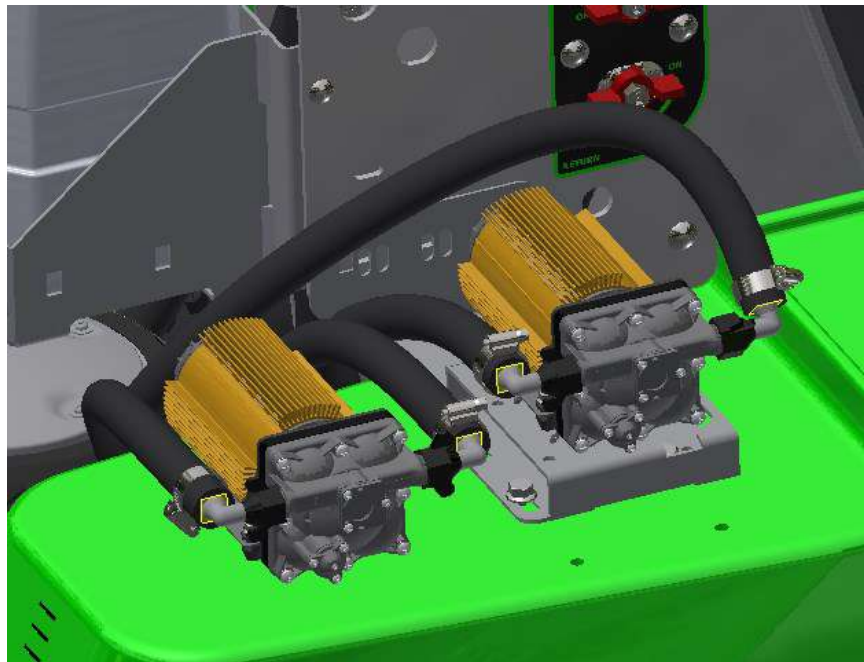

HI-FLOW \ DOUBLE SPRAY PUMP SWAP

CAUTION!

Before beginning any of the following instructions BESURE all the tanks have been drained

STEP ONE: Disconnect the battery, *ground* first and then *power* wire.



GROUND

POWER

STEP TWO:

- Loosen the hose clamps & disconnect the suction & return hoses.
- Remove the pump & pump bracket by removing (4) bolts securing the pump & (4) bolts securing the bracket.

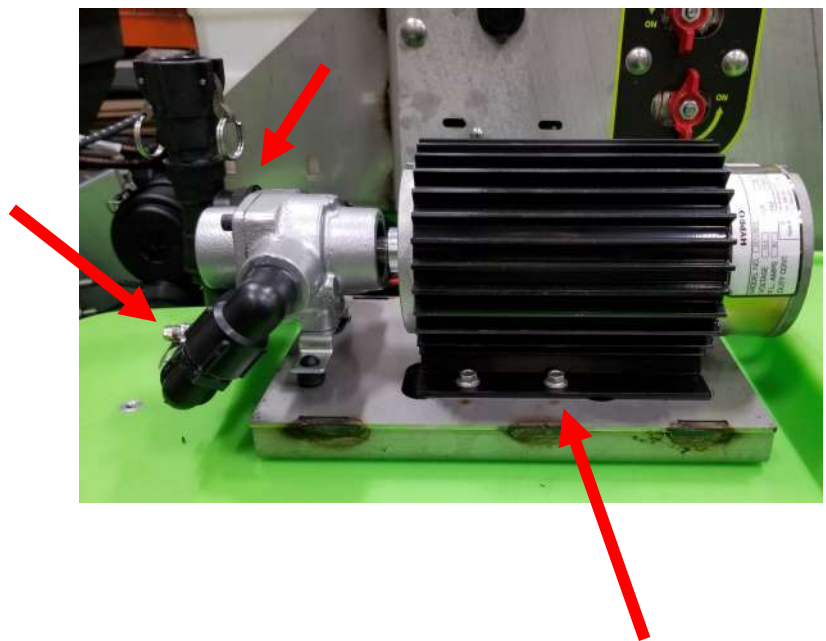

HI-FLOW \ DOUBLE SPRAY PUMP SWAP

STEP THREE: Attach both spray pumps to the tank

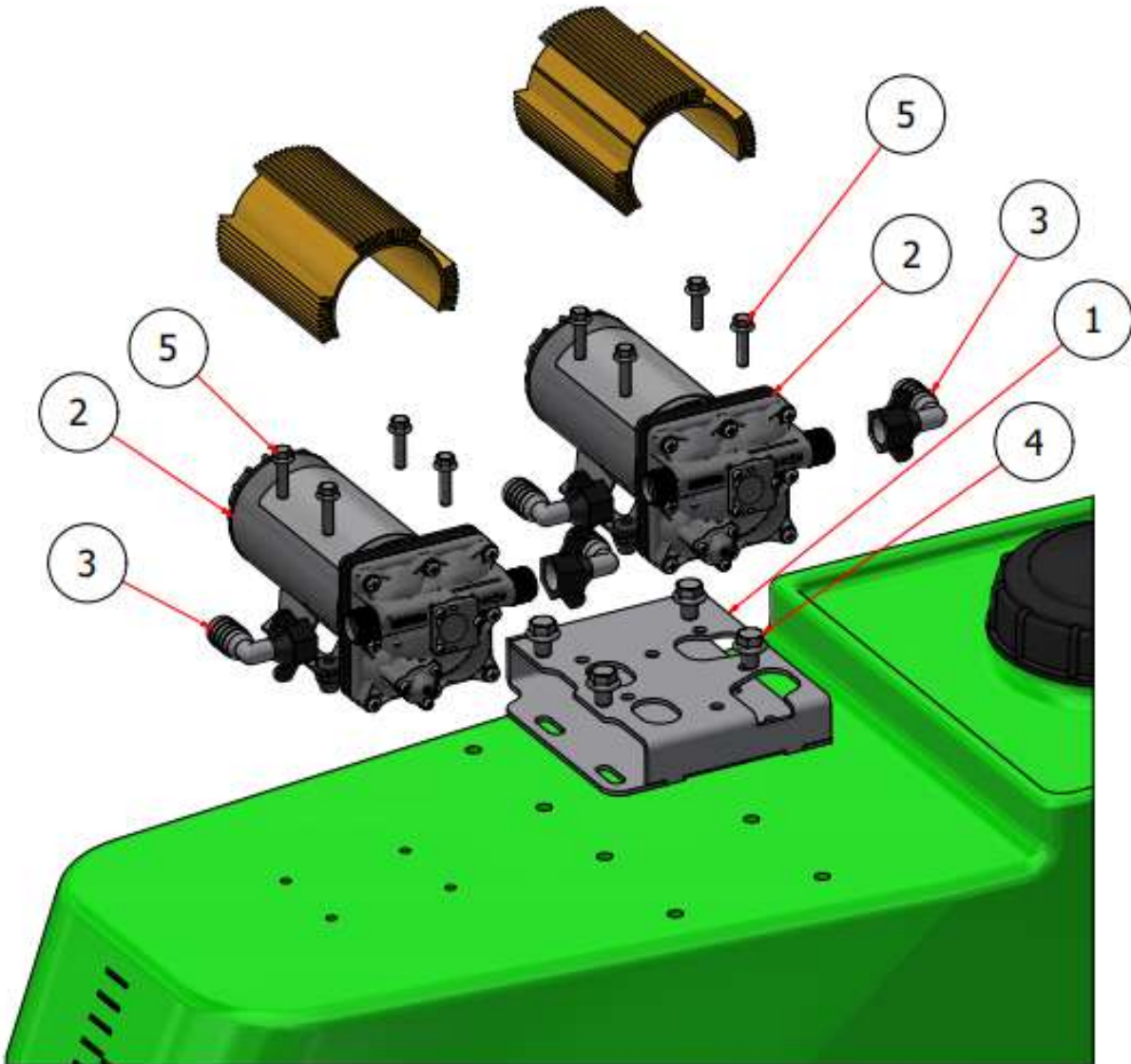

PARTS LIST

ITEM	QTY	PART NUMBER	DESCRIPTION
1	1	W21-100	BRACKET, PUMP
2	1	5059-3611-D011	SPRAY PUMP
3	2	S54102	PUMP FITTING, BARB, ELBOW
4	4	HFSSC-3812	HEX BOLT, 3/8 X 1/2
5	8	HFSSC-141	BOLT, HEX, 1/4 X 1

HI-FLOW \ DOUBLE SPRAY PUMP SWAP

STEP FOUR:

- Cut 3/4" suction hose 6-3/4" long.
- Connect the hose to the strainer "inlet port" and (S50062) 3-way "barb tee" to the other end.
- Securely fasten with 12HS hose clamps.

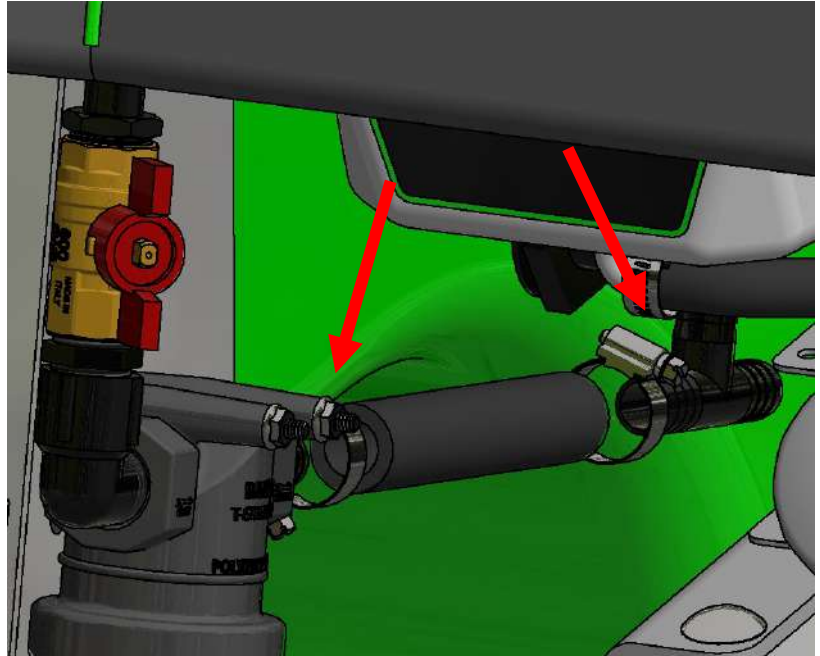

STEP FIVE:

- Cut 3/4" suction hose 27" long.
- Connect one end of the hose to the "barb" tee fitting and the other end to the "inlet port" of the spray pump 1.
- Securely fasten with 12HS hose clamps.

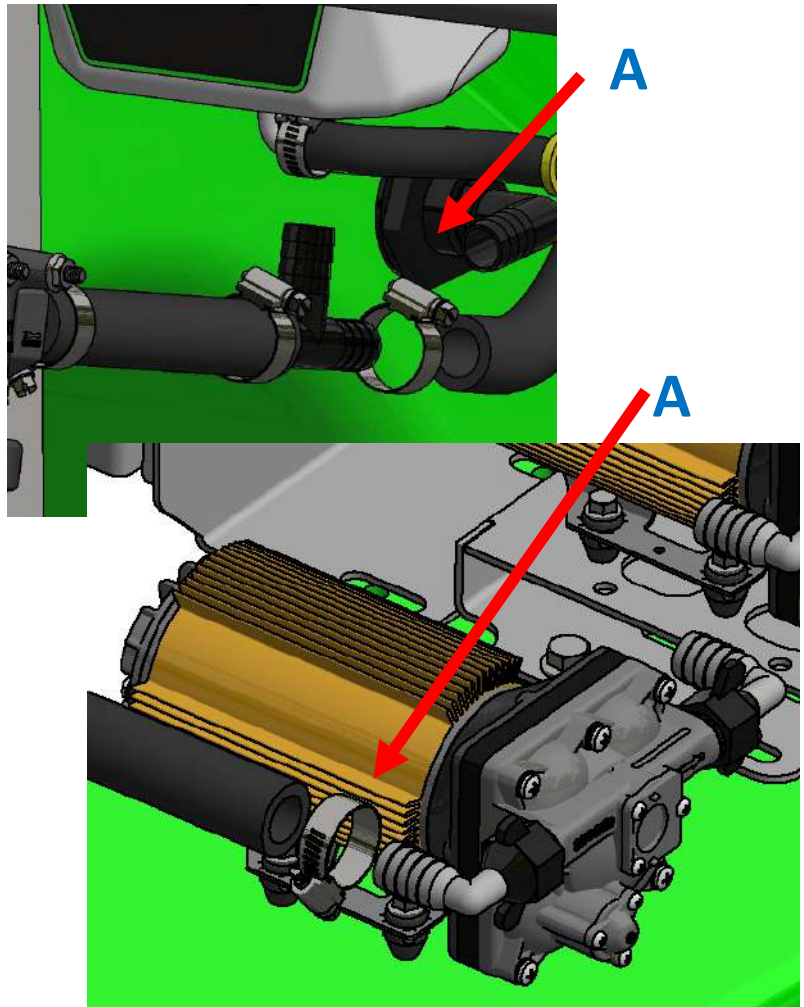

HI-FLOW \ DOUBLE SPRAY PUMP SWAP

STEP SIX:

- Cut 3/4" suction hose 22" long.
- Connect one end of the hose to the "barb" tee fitting and the other end to the "inlet port" of spray pump 2.
- Securely fasten with 12HS hose clamps.

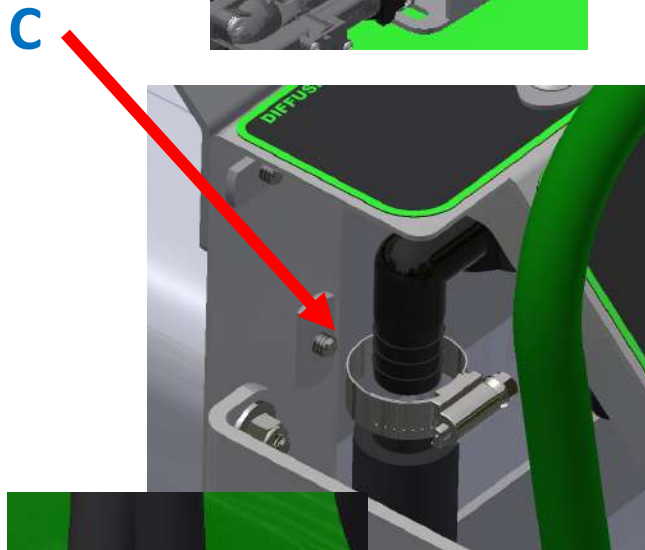
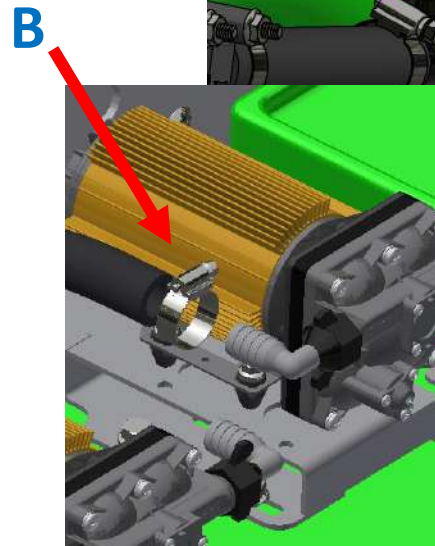
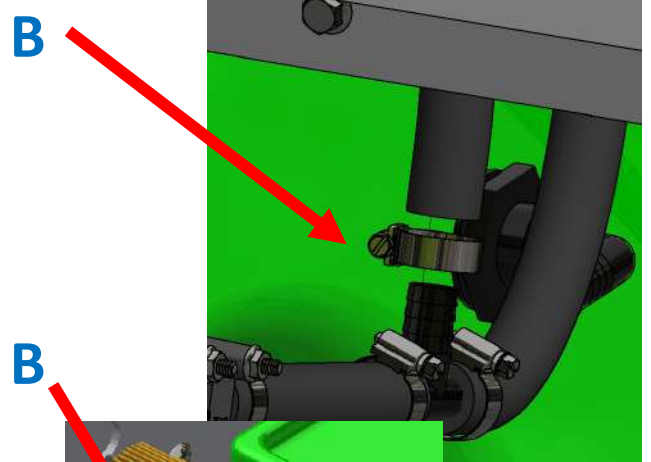

STEP SEVEN:

- Cut 3/4" return hose 16" long.
- Connect one end of the hose to the spray manifold inlet "barb" fitting and attach a (S50062) 3-way "barb tee" to the other end.
- Securely fasten with 12HS hose clamps.

NOTE: The "tee fitting" faces the front of the machine.



HI-FLOW \ DOUBLE SPRAY PUMP SWAP

STEP EIGHT:

- Cut 3/4" suction hose 22" long.
- Connect one end of the hose to the bottom port of the "barb" tee fitting and the other end to the "outlet port" of spray pump 1.
- Securely fasten with 12HS hose clamps.

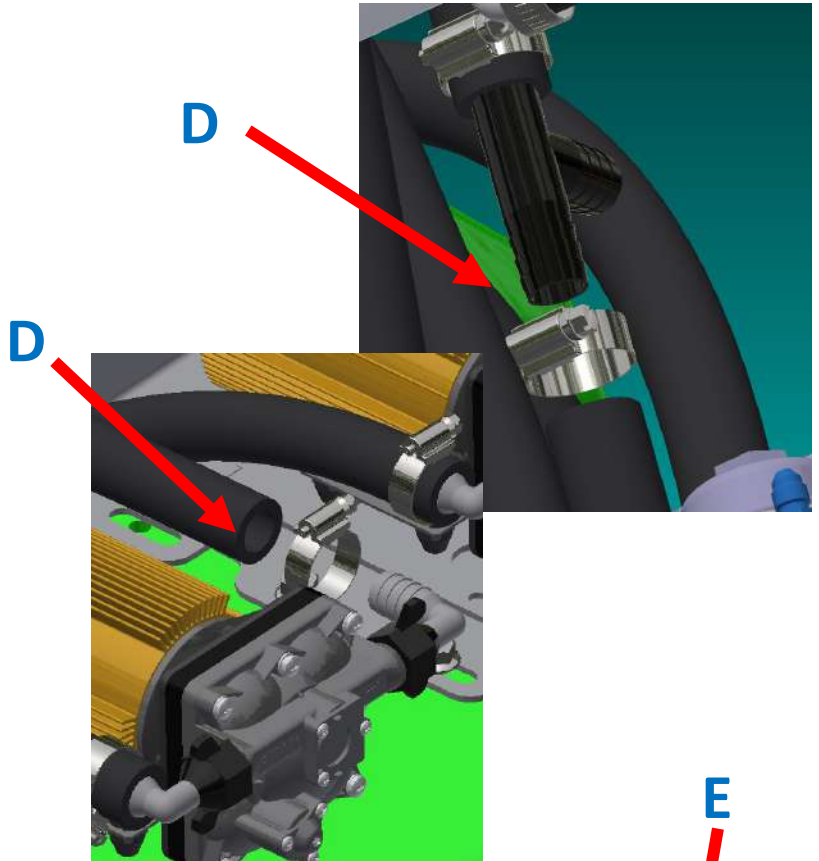

STEP NINE:

- Cut 3/4" return hose 27" long.
- Connect one end of the hose to the "barb" tee fitting and attach the other end to the "outlet port" of spray pump 2.
- Securely fasten with 12HS hose clamps.

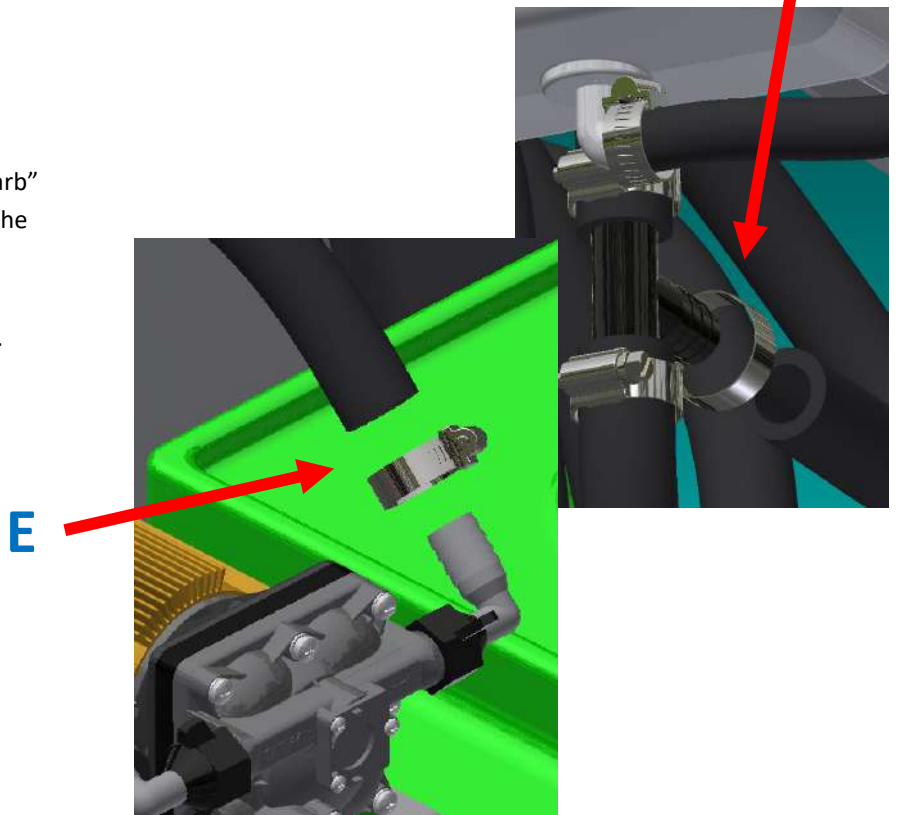

HI-FLOW \ DOUBLE SPRAY PUMP SWAP

STEP TEN: Plug the “y” adapter into the plug of the hi flow harness and plug the other ends into each spray pump.



STEP ELEVEN:

- Reconnect the battery cables, power cable and wires first followed by the ground wire.
- Attach the battery box cover and bungee strap.



GROUND

POWER



Steel Green Mfg.
824 S State Road 39
Lebanon, IN 46052
(765)-481-2890

www.steelgreenmfg.com

MANUAL PART NO.	MANUAL REV.	DESCRIPTION
SGM-022	B	SG HI-FLOW DOUBLE SPRAY PUMP SWAP