

INSTRUCTION MANUAL

SG DRIVE BELT REPLACEMENT

Models: SG36, SG42, SG46, & SG52

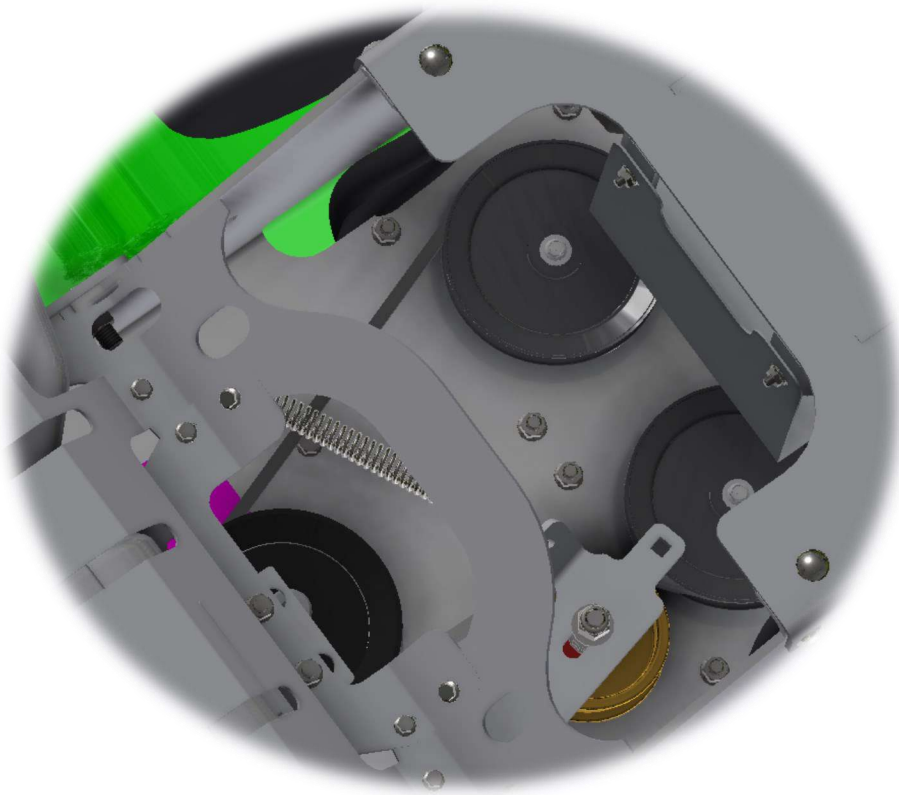

DRIVE BELT SWAP INSTRUCTIONS

STEP ONE: Remove the kick panel from the machine.

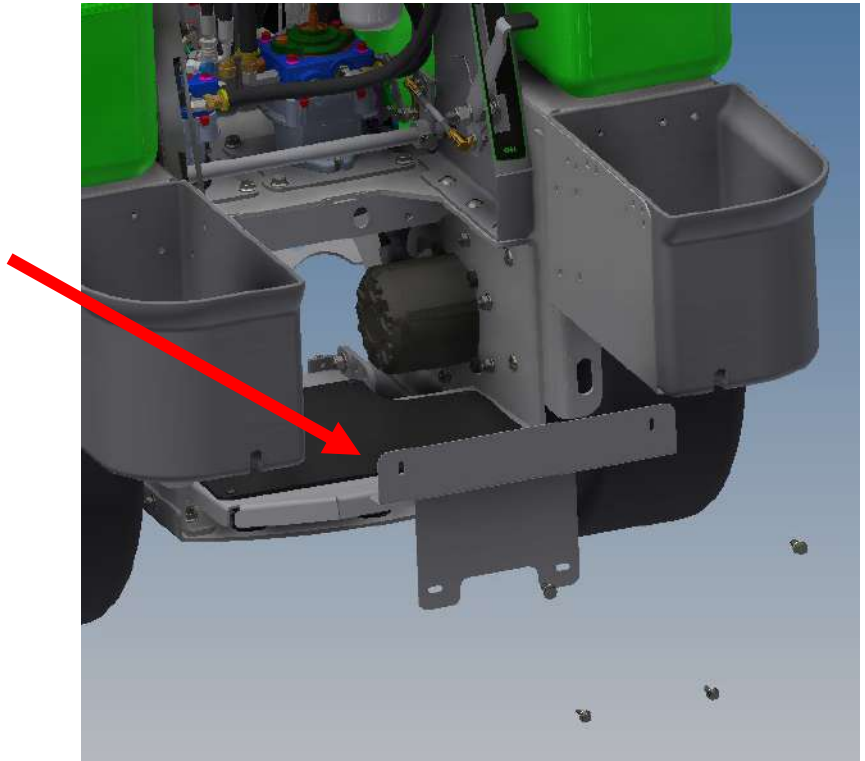

NOTE:

- Before starting the next step, note there is a notch in the idler arm for a 3/8" ratchet.
- If the ratchet should not fit the notch, use a file to remove any burs.

STEP TWO:

- Reach in from the rear of the machine with a 3/8" ratchet and attach it to the notch in the idler arm.
- Release the tension from the old belt and remove it.
- Hold the idler arm back and install the new belt, release the idler arm to reapply tension, and remove the ratchet.

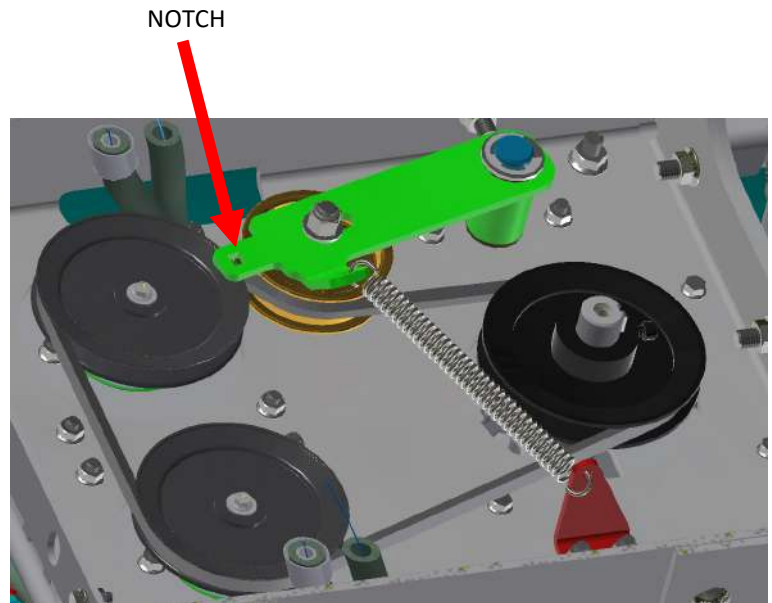

DRIVE BELT SWAP INSTRUCTIONS

STEP THREE: Reinstall the kick panel to the machine.

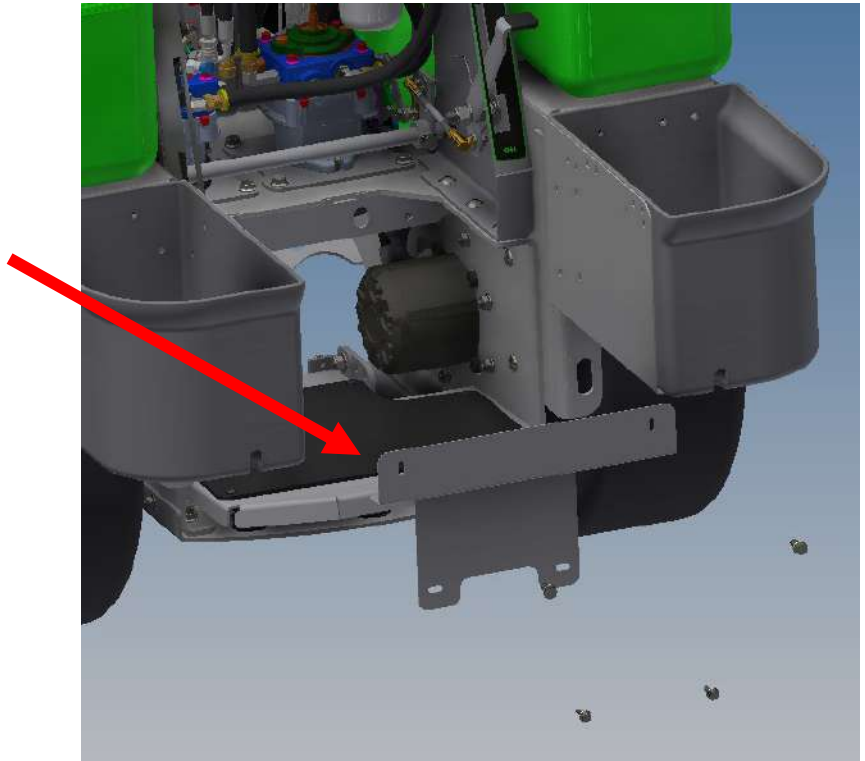



Steel Green Mfg.
824 S State Road 39
Lebanon, IN 46052
(765)-481-2890
www.steelgreenmfg.com

MANUAL PART NO.	MANUAL REV.	DESCRIPTION
SGM-016	B	SG DRIVE BELT REPLACEMENT