

INSTRUCTION MANUAL

7 GAL. SUPPLEMENTAL TANK

Models: SG46, & SG52

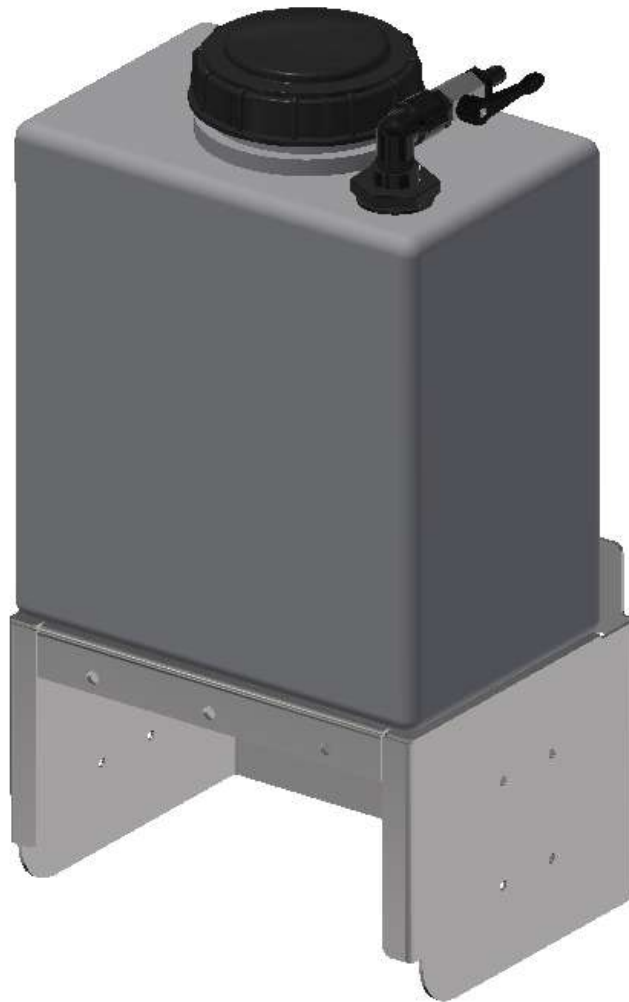

7 GAL. SUPPLEMENTAL EXPLODED VIEW \ LEFT SIDE

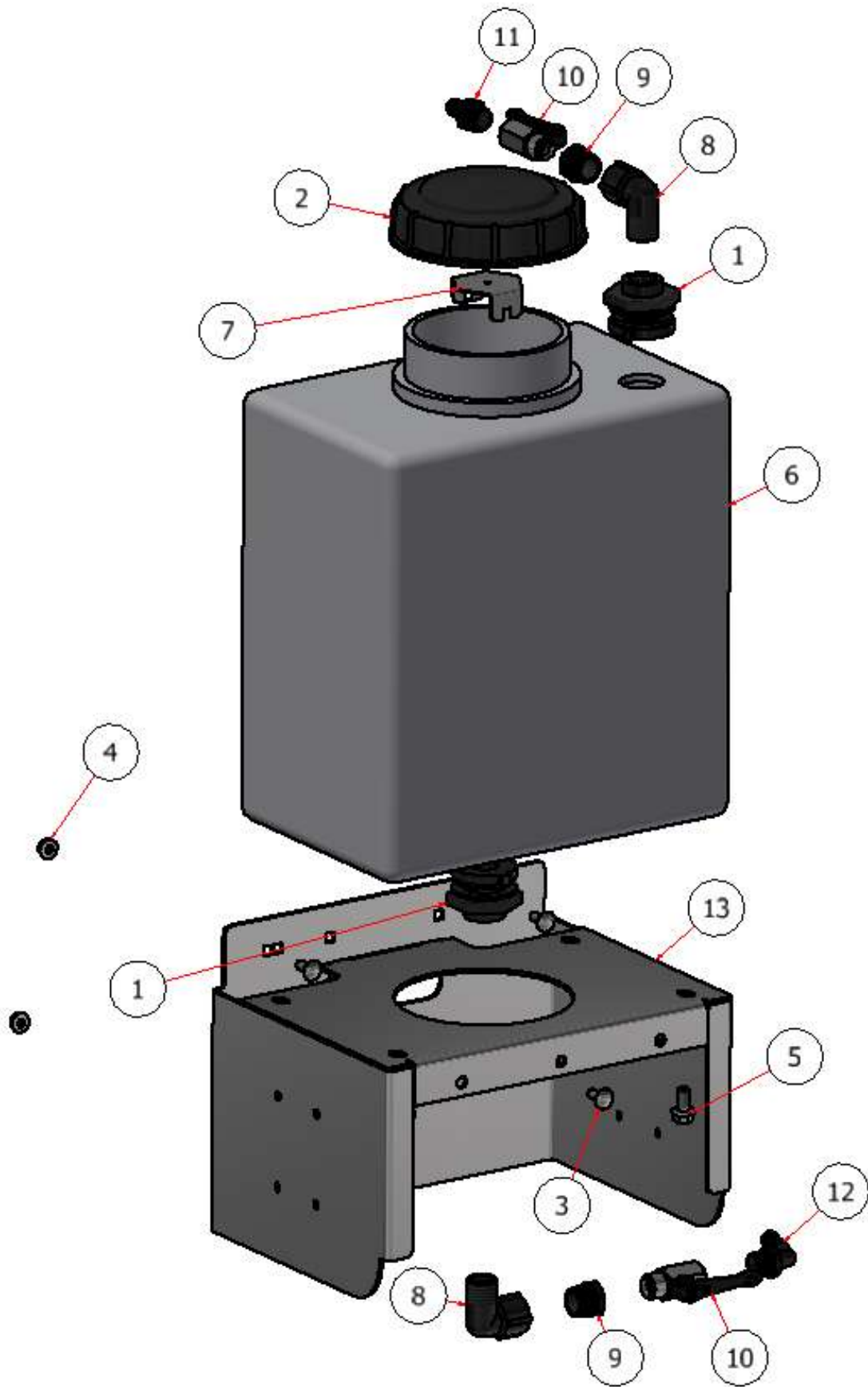

7 GAL. SUPPLEMENTAL EXPLODED VIEW \ LEFT SIDE

PARTS LIST			
ITEM	QTY	PART NUMBER	DESCRIPTION
1	2	S51242	BULKHEAD FITTING, TANK
2	1	S51243	CAP, TANK
3	4	CB-51634	CARRIAGE BOLT, SS - 5/16-18 x 3/4
4	4	HFNCS-516S	HEX FLANGE NUT, SS - 5/16-18
5	4	HFSSC-3875	HEX FLANGE BOLT, 3/8 X 3/4
6	1	M10007-R	TANK, 7 GALLON
7	1	R21-113	ANTI VORTEX PLATE
8	2	S52041	90 ELBOW, 3/4 MNPT X 3/4 FNPT
9	2	S52051	BUSHING, PIPE, 3/4 X 1/2
10	2	S51266	1/2 BALL VALVE
11	1	S52013	1/2 MNPT X 1/2 HOSE BARB
12	1	S52025	1/2 MPT X 1/2 BARB
13	1	W22-183	TANK SUPPORT, 7 GAL. SG46/52

7 GAL. SUPPLEMENTAL EXPLODED VIEW \ RIGHT SIDE

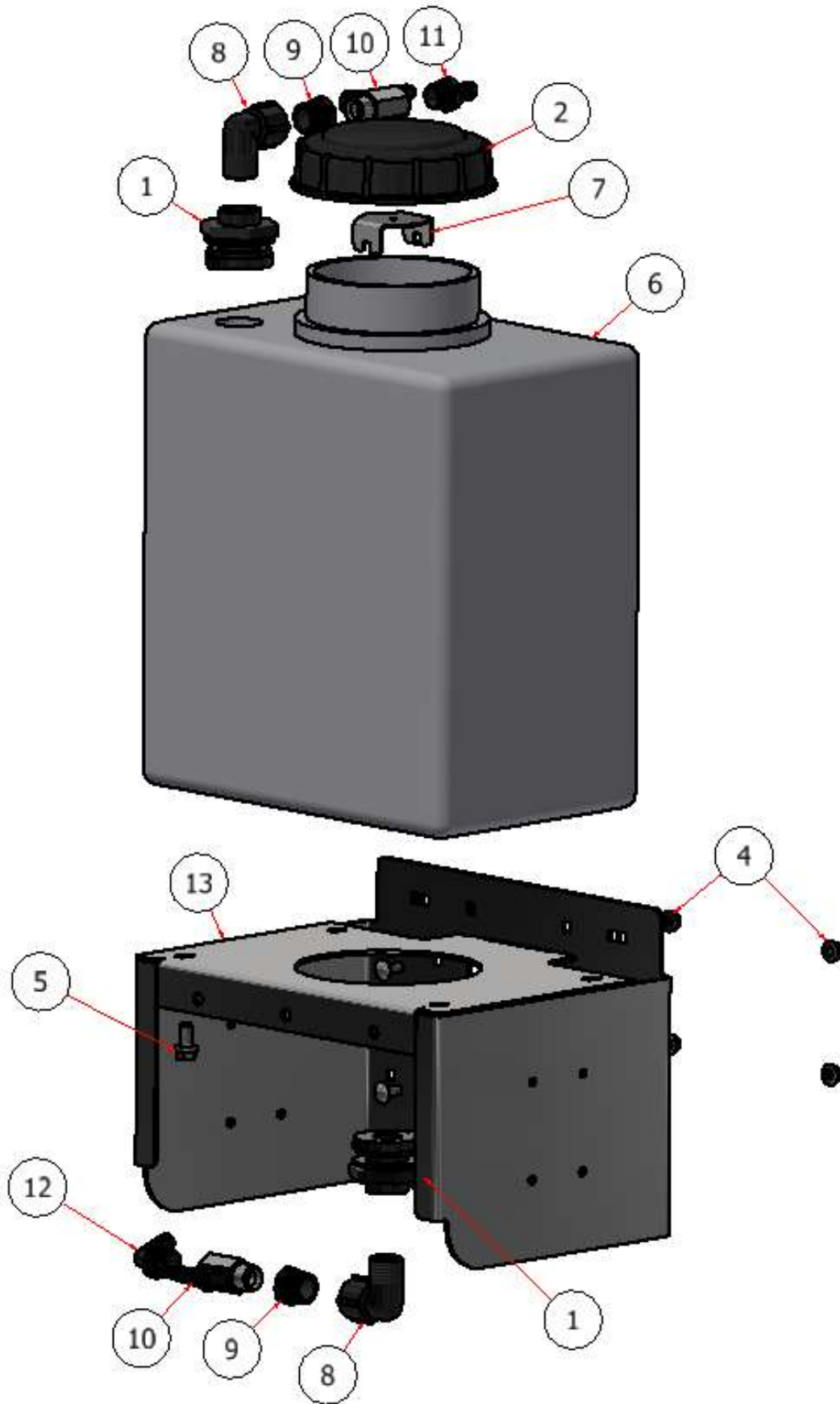

7 GAL. SUPPLEMENTAL EXPLODED VIEW \ RIGHT SIDE

PARTS LIST			
ITEM	QTY	PART NUMBER	DESCRIPTION
1	2	S51242	BULKHEAD FITTING, TANK
2	1	S51243	CAP, TANK
3	4	CB-51634	CARRIAGE BOLT, SS - 5/16-18 x 3/4
4	4	HFNCS-516S	HEX FLANGE NUT, SS - 5/16-18
5	4	HFSSC-3875	HEX FLANGE BOLT, 3/8 X 3/4
6	1	M10007-R	TANK, 7 GALLON
7	1	R21-113	ANTI VORTEX PLATE
8	2	S52041	90 ELBOW, 3/4 MNPT X 3/4 FNPT
9	2	S52051	BUSHING, PIPE, 3/4 X 1/2
10	2	S51266	1/2 BALL VALVE
11	1	S52013	1/2 MNPT X 1/2 HOSE BARB
12	1	S52025	1/2 MPT X 1/2 BARB
13	1	W22-183	TANK SUPPORT, 7 GAL. SG46/52

7 GAL. SUPPLEMENTAL TANK ASSEMBLY INSTRUCTIONS

STEP ONE: Disconnect the battery, *ground* first and then *power* wire.



GROUND

POWER

STEP TWO: Remove existing storage container and support bracket from the frame.

NOTE: *Instructions are the same for the right and left side.*

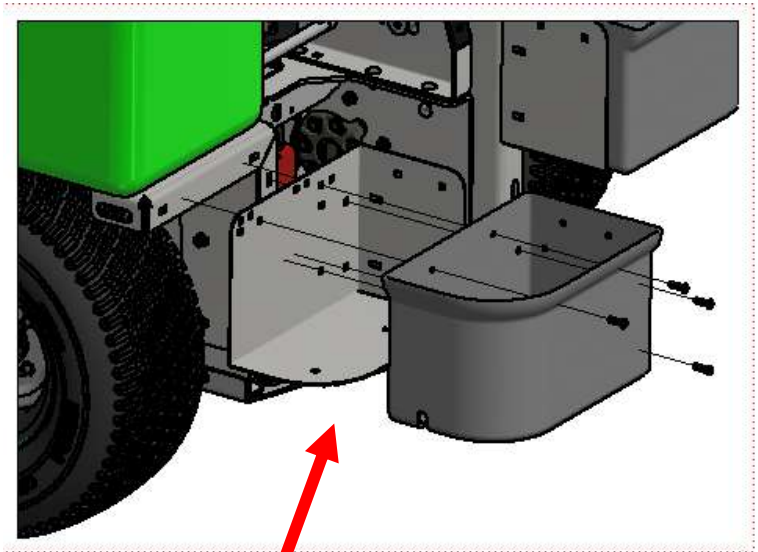

7 GAL. SUPPLEMENTAL TANK ASSEMBLY INSTRUCTIONS

STEP THREE: Install the supplemental tank to the frame as shown.

NOTE:

- *Instructions are the same for the right and left side.*
- *Parts shown clear for clarity.*

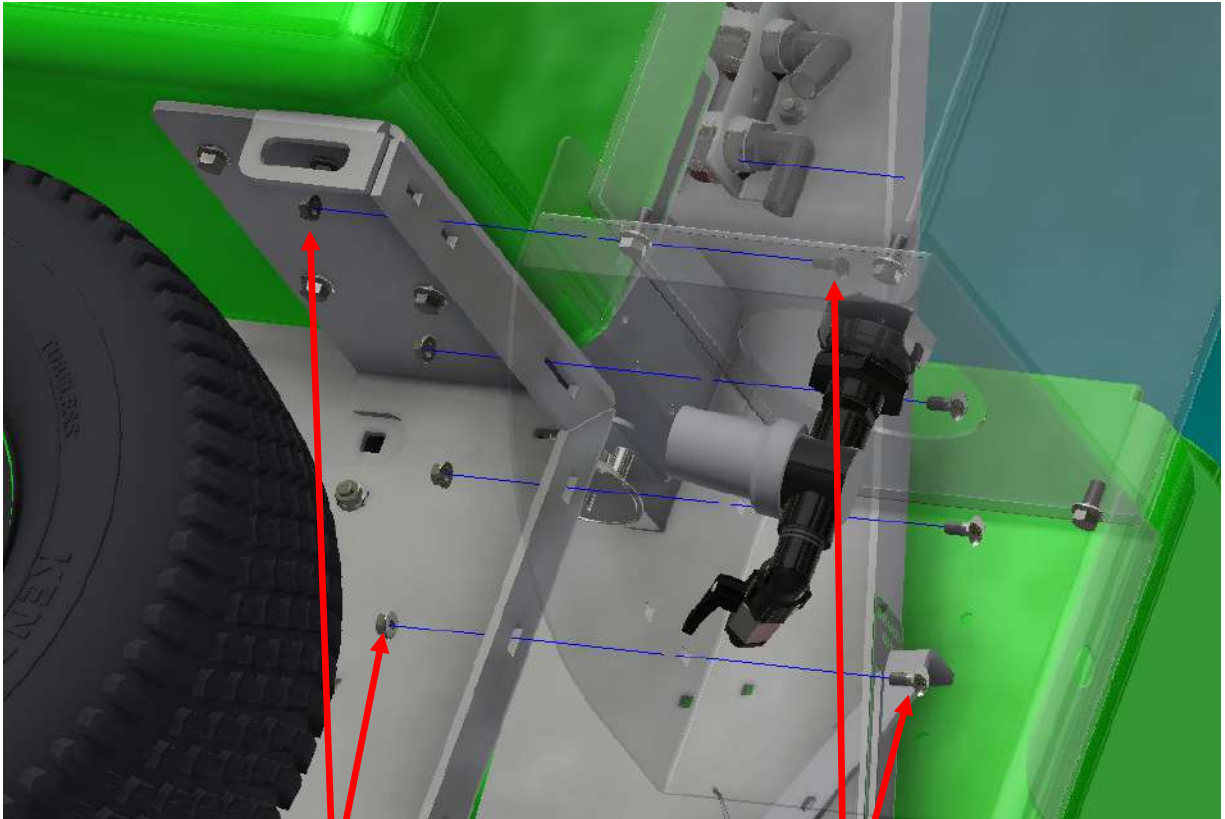

Hex nuts HFNCS-516S qty. (4)

Carriage bolts CB-51634 qty. (4)

7 GAL. SUPPLEMENTAL TANK ASSEMBLY INSTRUCTIONS

NOTE:

- Before beginning step four, BE SURE there is no pressure on the lines and fluid is drained.
- Parts removed for clarity.

STEP FOUR:

- Carefully cut and install the “tee” fittings in the “suction” and “return” lines as shown (blue arrows). Securely fasten with 3/4 hose clamps.
- Next install the 90 degree elbows.

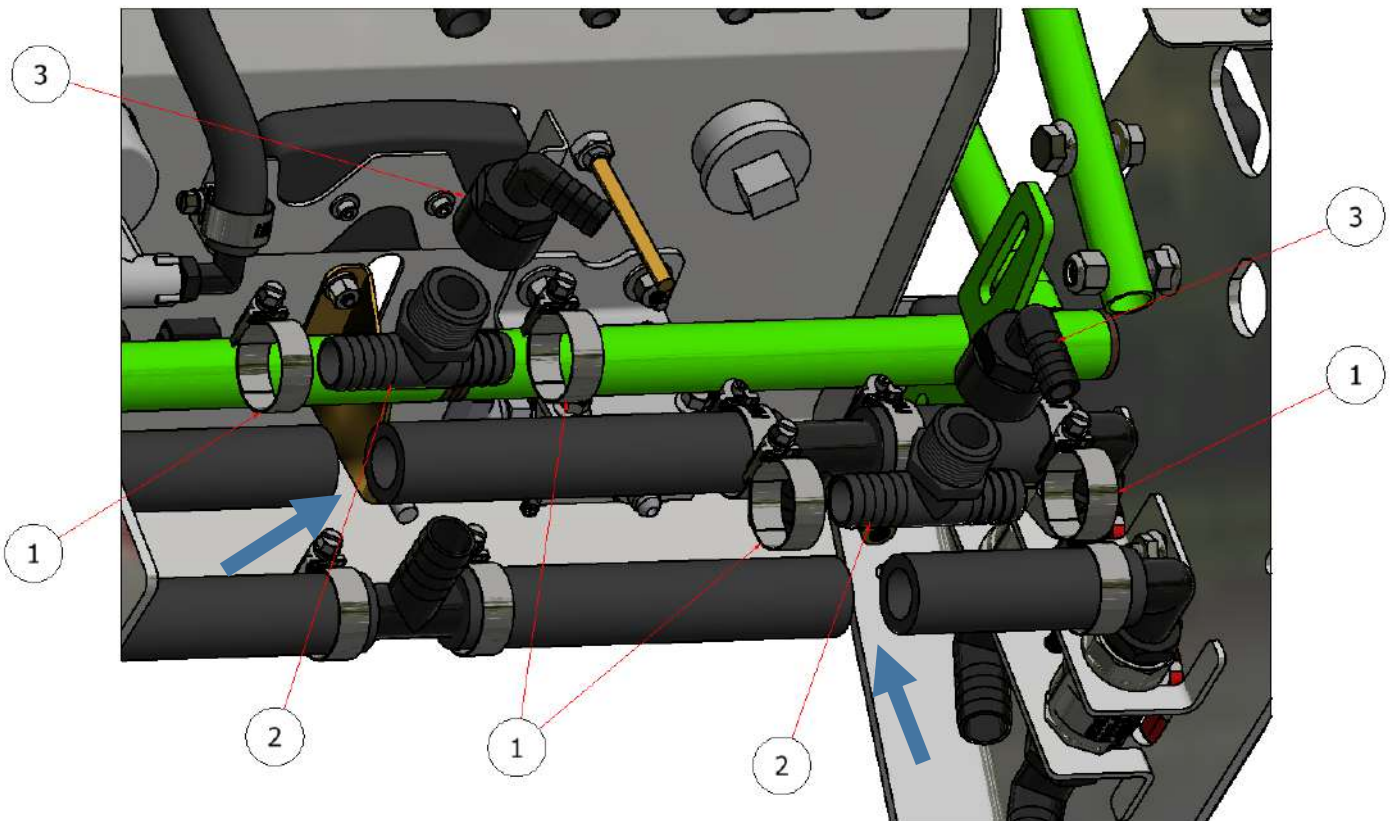

PARTS LIST

ITEM	QTY	PART NUMBER	DESCRIPTION
1	4	12HS	HOSE CLAMP, 3/4
2	2	S52009	TEE FITTING, 3/4 HOSE X 3/4 MNPT
3	2	S52035	3/4 FNPT X 1/2 HOSE BARB

7 GAL. SUPPLEMENTAL TANK ASSEMBLY INSTRUCTIONS

STEP FIVE:

NOTE: Slide the protective wrap over the hose and secure it with zip ties before connecting.

- Measure and cut 1/2" hose and connect one end to the suction port on the bottom of the 7 gallon tank and the other end to the "tee" fitting in the suction line.
- Route the hose between the upright and the tank.
- Securely fasten each end with 1/2" hose clamp.

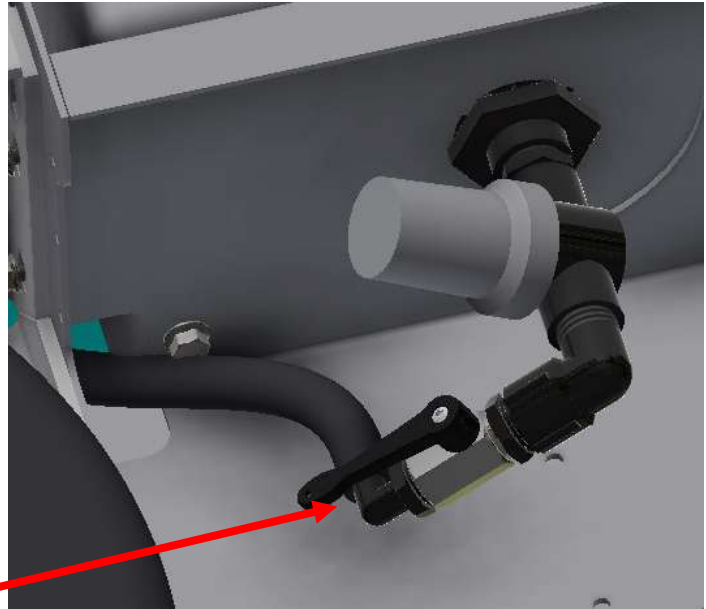

A

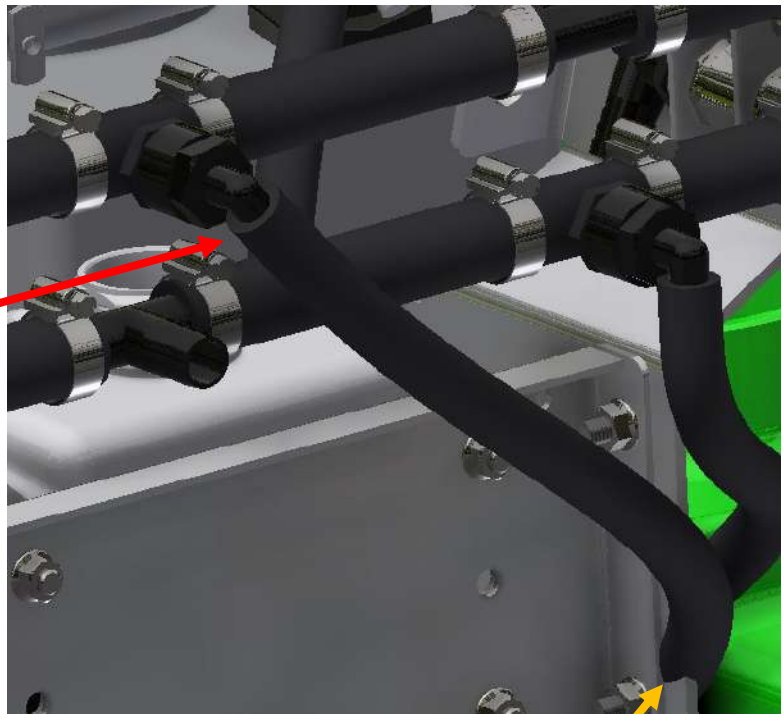

A

7 GAL. SUPPLEMENTAL TANK ASSEMBLY INSTRUCTIONS

STEP SIX:

NOTE: Slide the protective wrap over the hose and secure it with zip ties before connecting.

- Measure and cut 1/2" hose, connecting one end to the return port on the top of the 7 gallon tank and the other end to the "tee" fitting in the return line.
- Route the hose between the upright and the tank.
- Securely fasten each end with 1/2" hose clamps.

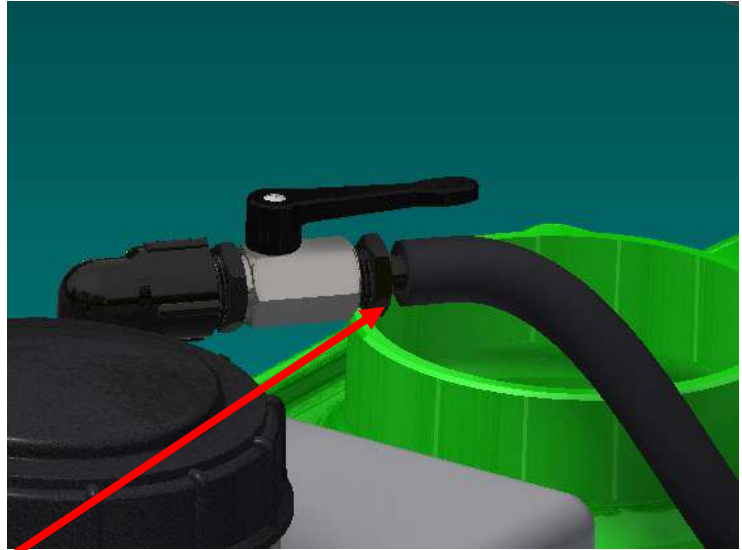

B

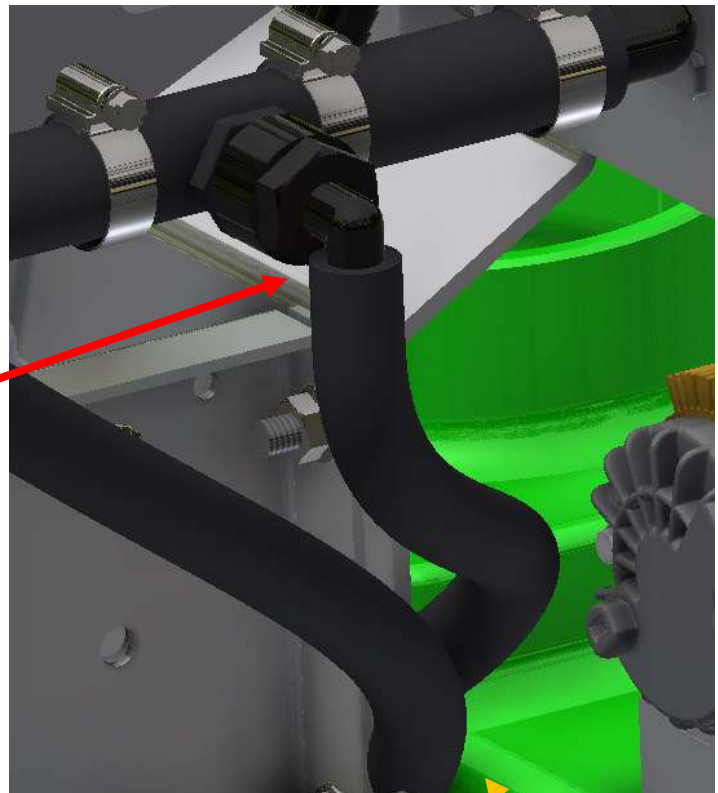

B

7 GAL. SUPPLEMENTAL TANK ASSEMBLY INSTRUCTIONS

STEP SEVEN: Reconnect the battery *power wire* first along with the *pump power wire* from the wiring harness, and then reconnect the *ground wire*.



GROUND

POWER



Steel Green Mfg.
824 S State Road 39
Lebanon, IN 46052
(765)-481-2890
www.steelgreenmfg.com

MANUAL PART NO.	MANUAL REV.	DESCRIPTION	KIT PART NO.
SGM-011	B	SG46-52 7 GALLON SUPPLIMENTAL TANK	P10032