

INSTRUCTION MANUAL

STAINLESS STEEL RATE DIAL HOLDER OPTION

Models: SG36, SG42, SG46, & SG52



RATE DIAL HOLDER INSTALL INSTRUCTIONS

STEP ONE: Remove the clip and spinner.

CAUTION!

Be sure the hopper is empty before starting the following steps.

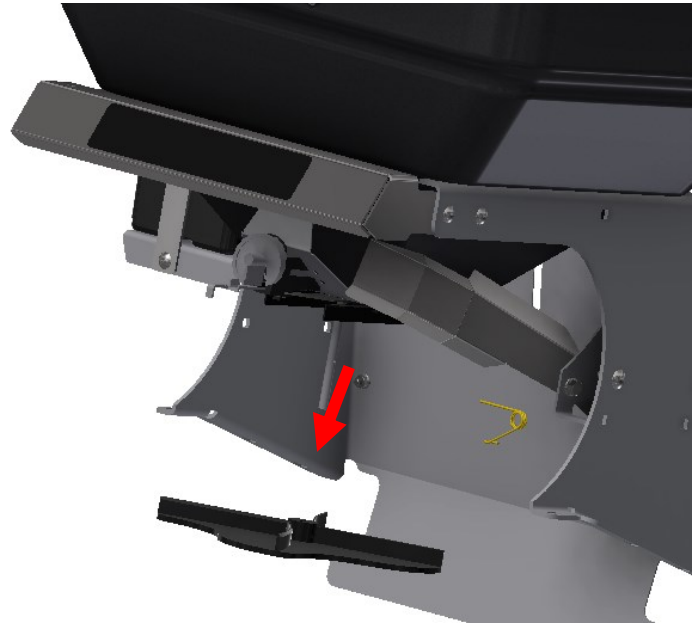

STEP TWO: Set the rate dial to "6" and measure the gate opening .

NOTE: Write down the measurement to be used to install the new dial holder.

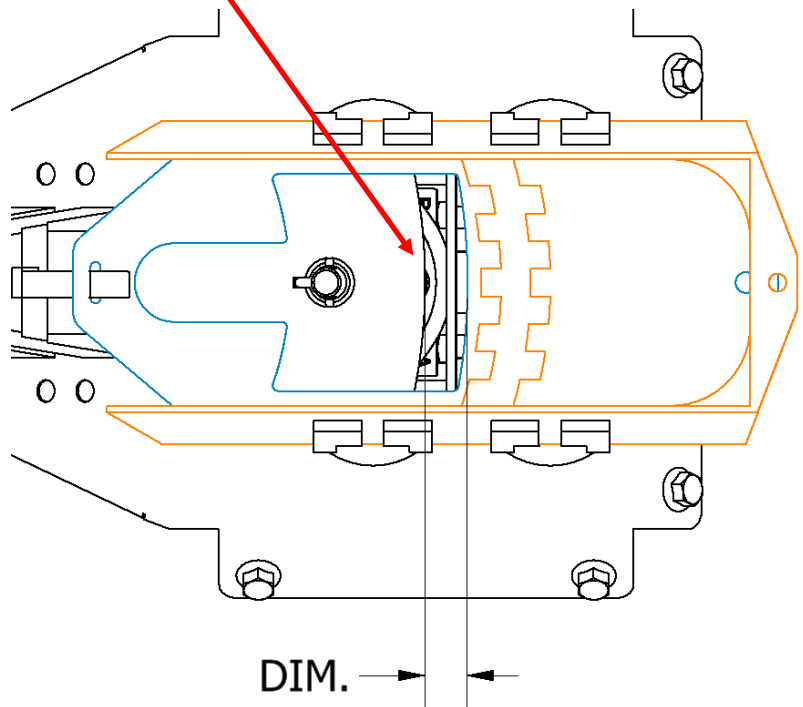

HOPPER BOTTOM VIEW

RATE DIAL HOLDER INSTALL INSTRUCTIONS

NOTE: Holes will need to be drilled in gate frame. Step 3 is optional, the gate assembly is siliconed to the hopper tub. It will have to be re-siliconed if removed.

NOTE: If you choose to leave the assembly on the unit, remove the hopper shaft to slide the rate dial holder assembly out.

STEP THREE:

- Disconnect the gate and diffuser cable.
- Remove the (8) bolts and remove the gate assembly from the hopper tub.

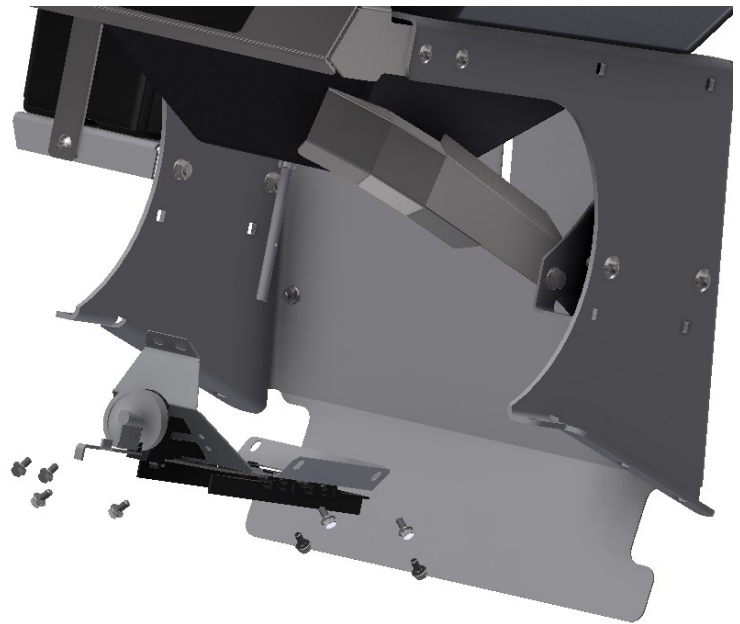

WARNING!

If you choose to leave the assembly attached to the tub, place a piece of wood between the frame and hopper tub to keep from drilling through the hopper tub.

STEP FOUR:

- Squeeze the rate dial holder to disconnect it from the gate assembly.
- Slide the rate dial assembly along with the gate out of the frame.

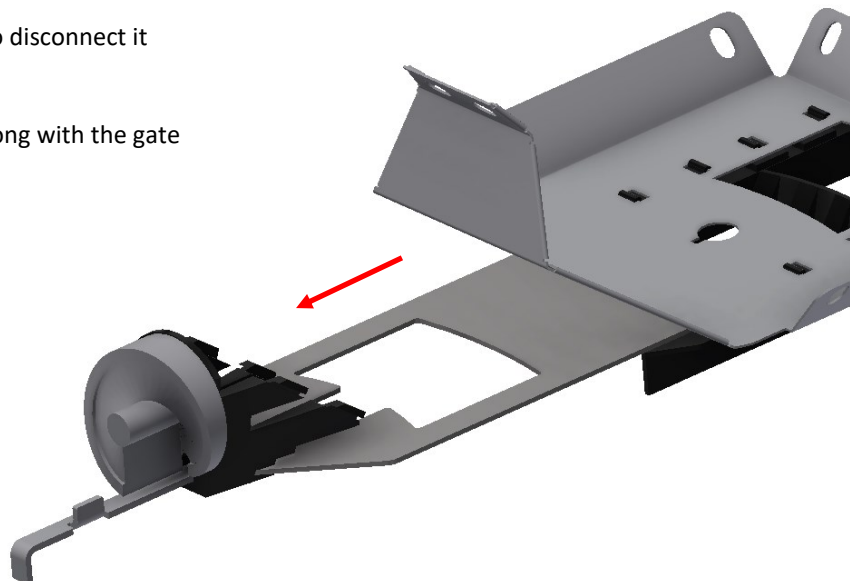

RATE DIAL HOLDER INSTALL INSTRUCTIONS

STEP FIVE: Disconnect the gate from the guide.

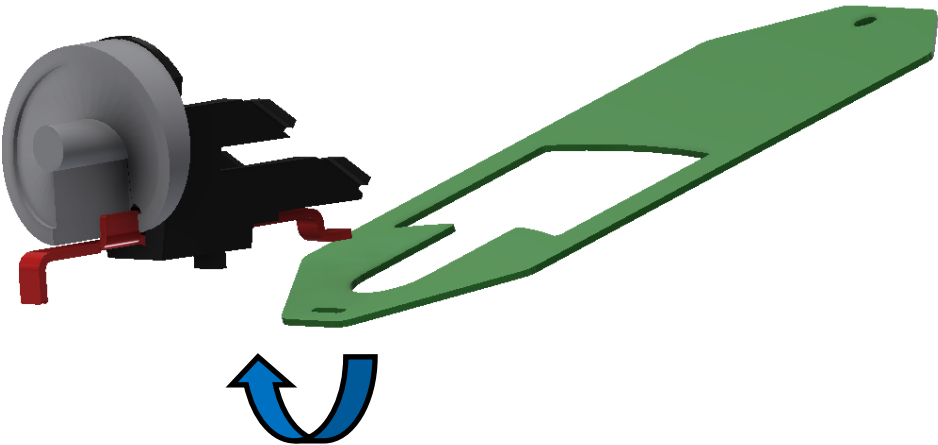

STEP SIX:

- Insert the guide through the opening of the rate dial provided with the kit.
- Re attach the gate to the guide.

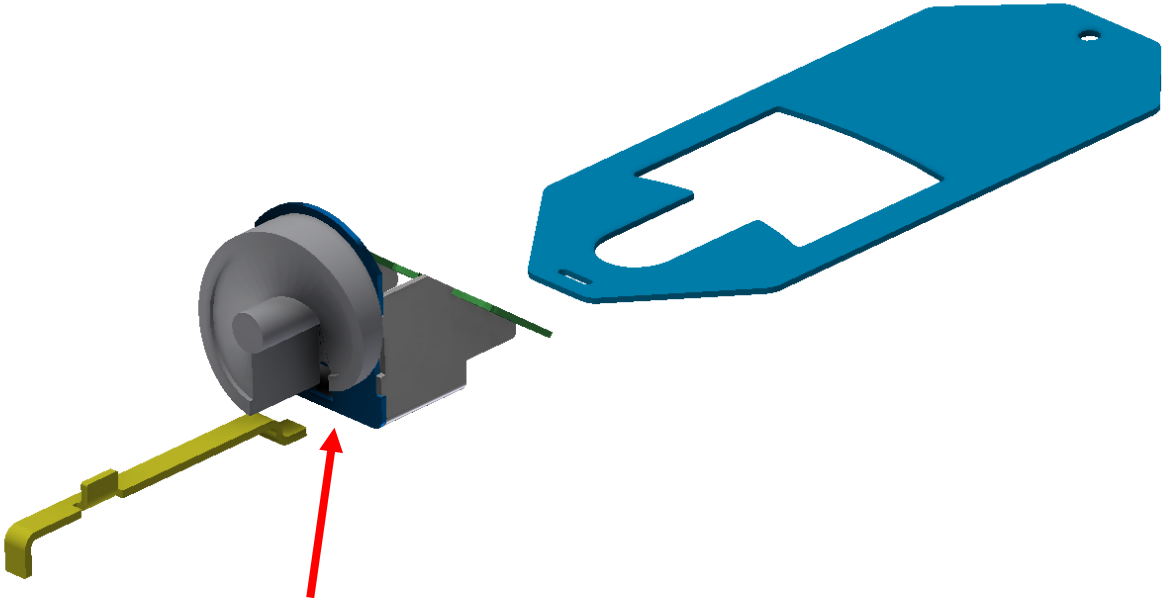

RATE DIAL HOLDER INSTALL INSTRUCTIONS

STEP SEVEN: Slide the new rate dial holder assembly into the frame.

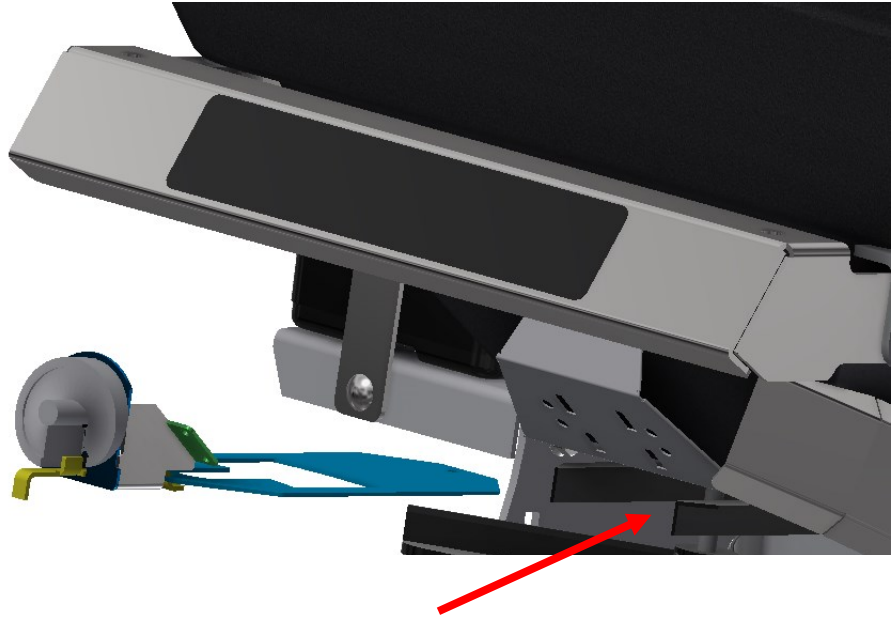

STEP EIGHT:

- Set the new rate dial to "6".
- Mark the holes on the plate using the measurement from step 2.
- Remove the rate dial and gate assembly.
- Drill the holes in the plate.

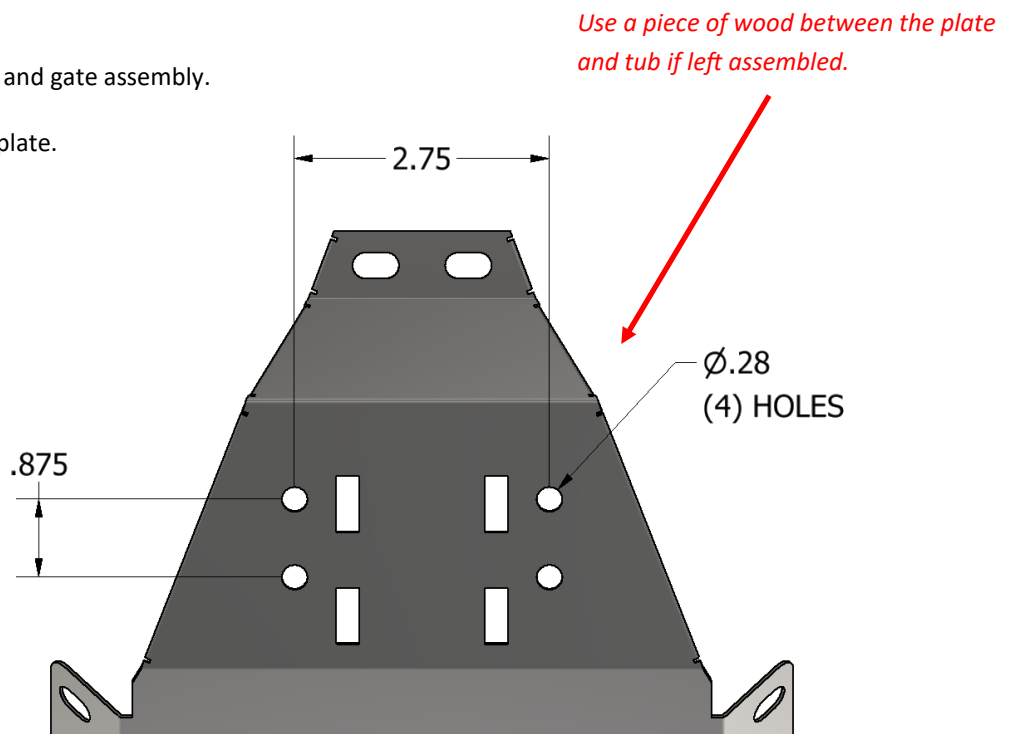

RATE DIAL HOLDER INSTALL INSTRUCTIONS

STEP NINE:

- Re attach the assembly to the hopper tub if it was removed.

NOTE: Be sure to re-silicone between the rate dial assembly and hopper tub.

- Re connect the gate and diffuser cables.
- Re install the new rate dial holder assembly.
- Attach the rate dial holder assembly to the frame with the (4) 1/4" X 1/2" bolts & (4) 1/4" nylock nuts provided with the kit.

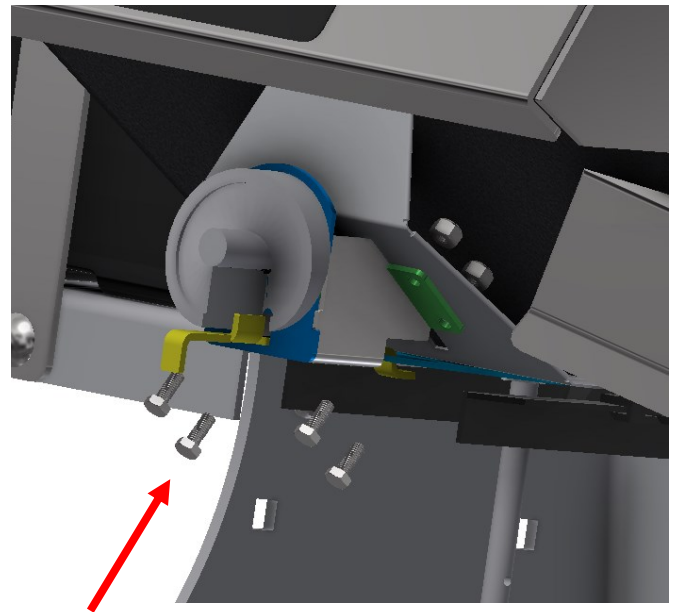
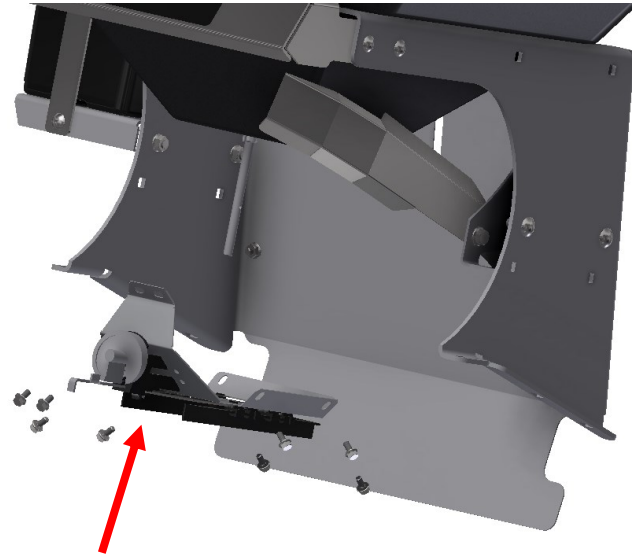

STEP TEN:

- Re attach the hopper shaft if it was removed.
- Re attach the spinner and clip.

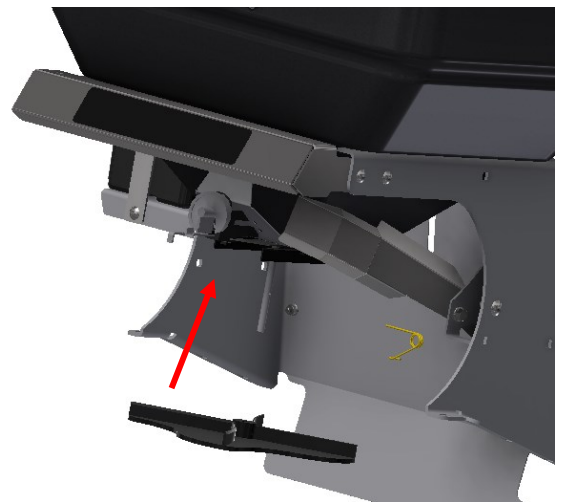

RATE DIAL HOLDER INSTALL INSTRUCTIONS

NOTES:



Steel Green Mfg.
824 S State Road 39
Lebanon, IN 46052
(765)-481-2890
www.steelgreenmfg.com

MANUAL PART NO.	MANUAL REV.	DESCRIPTION	KIT PART NO.
SGM-036	C	STAINLESS STEEL RATE DIAL HOLDER OPTION	K10027