

STEELGREEN[™]

MANUFACTURING

INSTRUCTION MANUAL

2.5 GALLON FOAM MARKER ATTACHMENT

Models: SG36, SG42, SG46, & SG52



2.5 GALLON FOAM MARKER EXPLODED

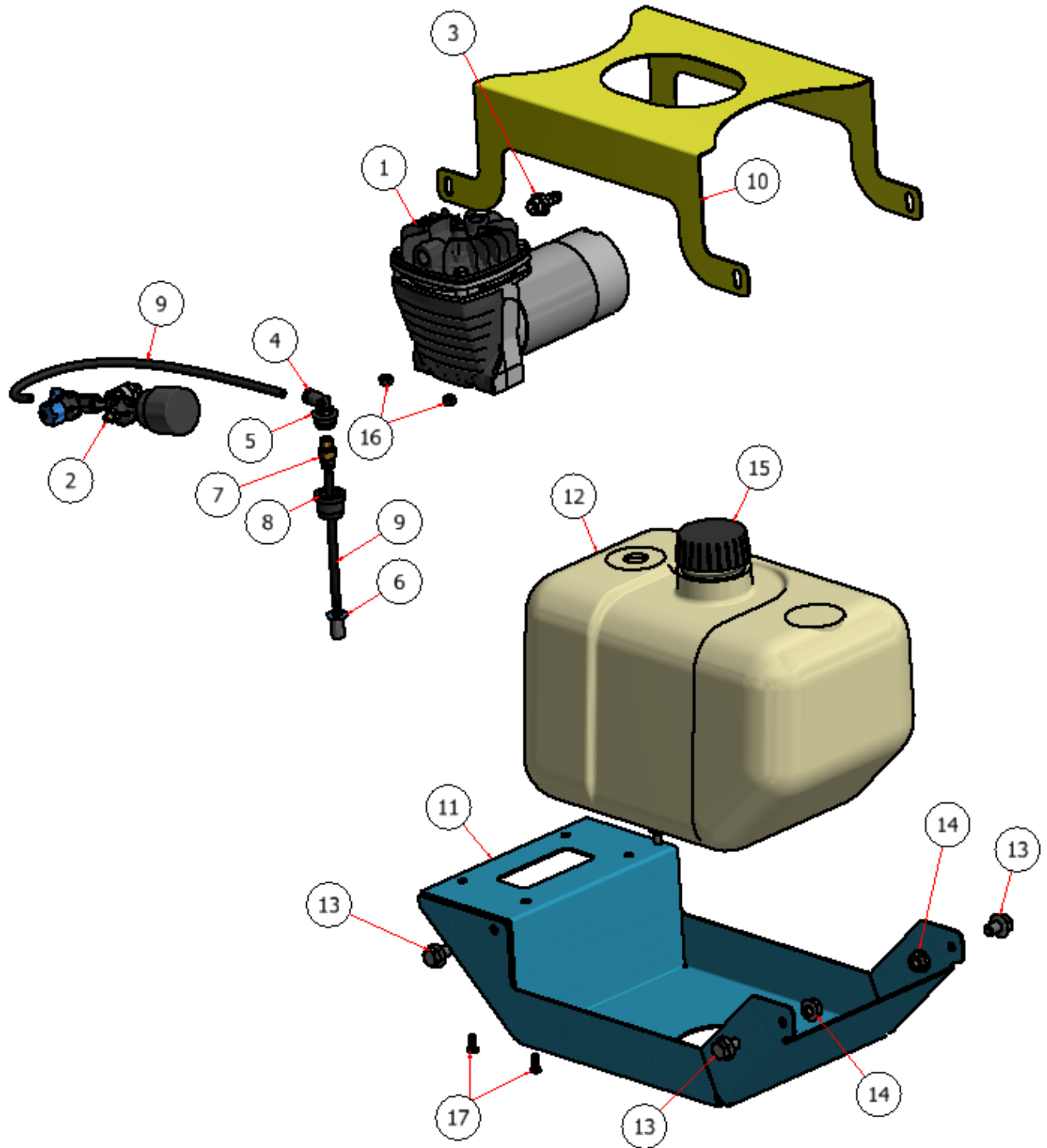

2.5 GALLON FOAM MARKER EXPLODED

FOAM MARKER PARTS LIST			
ITEM	QTY	PART NUMBER	DESCRIPTION
FOAM MARKER KIT K299501			
1	1	299501.09	MOTOR, FOAM MARKER
2	1	901843	VALVE ASSEMBLY, FOAM MARKER
3	1	200214	3/8" NPT X 3/8" BARB STG.
4	1	200186	TUBE ADAPTER, ELBOW, FOAM MARKER
5	1	901847	CONNECTER, PLASTIC, FOAM MARKER
6	1	S51280	CHECK VALVE 50 MESH
7	1	KQ2H07-34AS	CONNECTOR, TUBE, 1/4" X 1/8"
8	1	RUBBER SOCKET	RUBBER SOCKET, FOAM MARKER
9	1	230006	1/8" TUBE
10	1	R22-111	TANK TIE DOWN, FOAM MARKER
11	1	R22-110	TANK SUPPORT, FOAM MARKER
12	1	F10025	TANK, 2.5 GALLON, FOAM MARKER
13	4	HFSSC-3812	HEX BOLT, 3/8" X 1/2"
14	4	HFNCS-38S	HEX FLANGE NUT - 3/8-16
15	1	F10001	CAP, FOAM MARKER
16	2	SS NYLOCK 10-32	HEX NUT, NYLOCK, 10-32SS
17	2	TRPC-1012S	PHILLIPS SCREW, #10 X 1/2
18	1	SG-7G1	7 GAL. WIRE HARNESS

2.5 GALLON FOAM MARKER EXPLODED

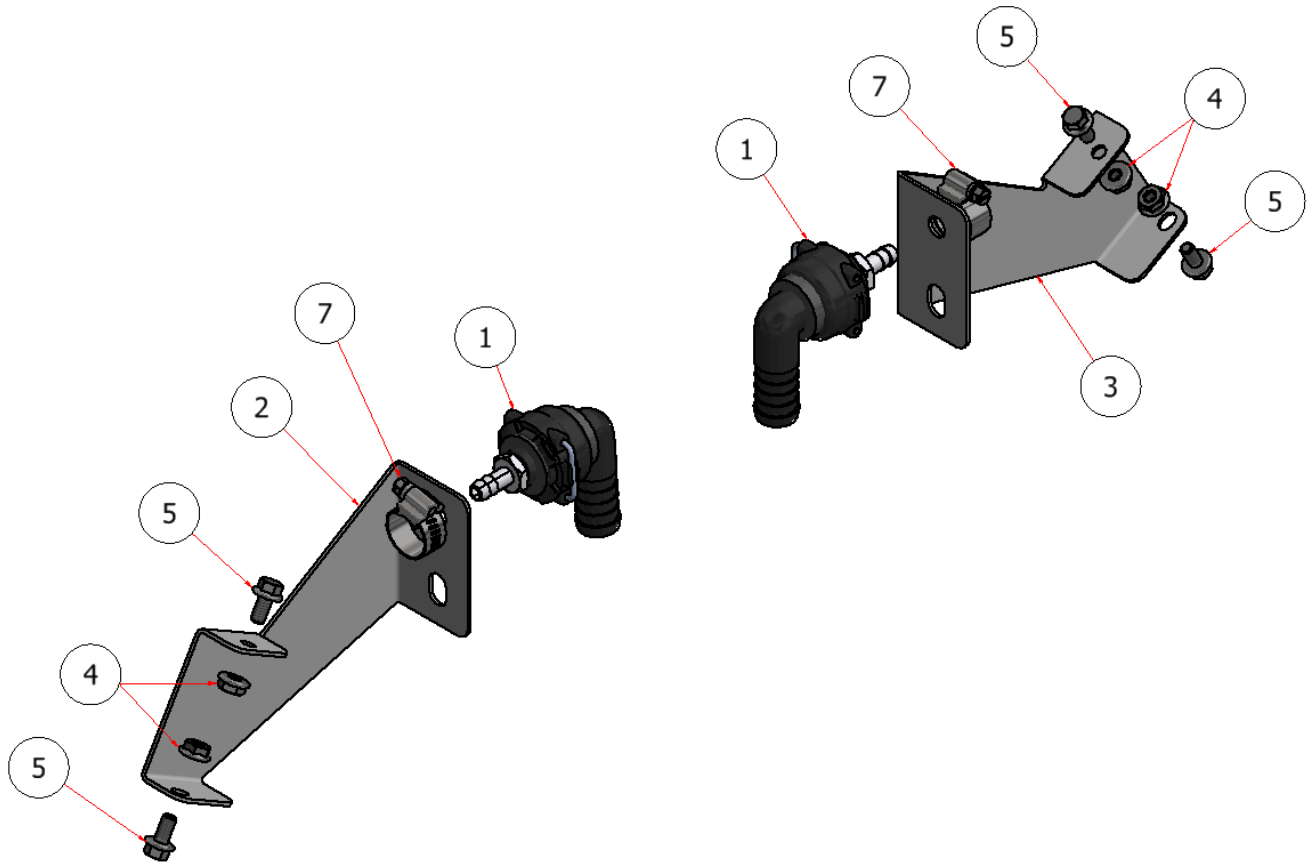

FOAM MARKER DROPPER PARTS LIST			
ITEM	QTY	PART NUMBER	DESCRIPTION
1	2	901699	DROPPER, FOAM MARKER
2	1	R22-114-R	BRACKET, DROPPER, FOAM MARKER, RIGHT
3	1	R22-114-L	BRACKET, DROPPER, FOAM MARKER, LEFT
4	8	SSHFN 0.25-20	HEX NUT, 1/4-20
5	4	HFSSC-145	HEX FLANGE BOLT, SS - 1/4-20 x 1/2
6	1	230039	3/8" HOSE
7	2	MS4	3/5" HOSE CLAMP
8	1	S50060	TEE FITTING, BARB, 3/8"

2.5 GALLON FOAM MARKER EXPLODED

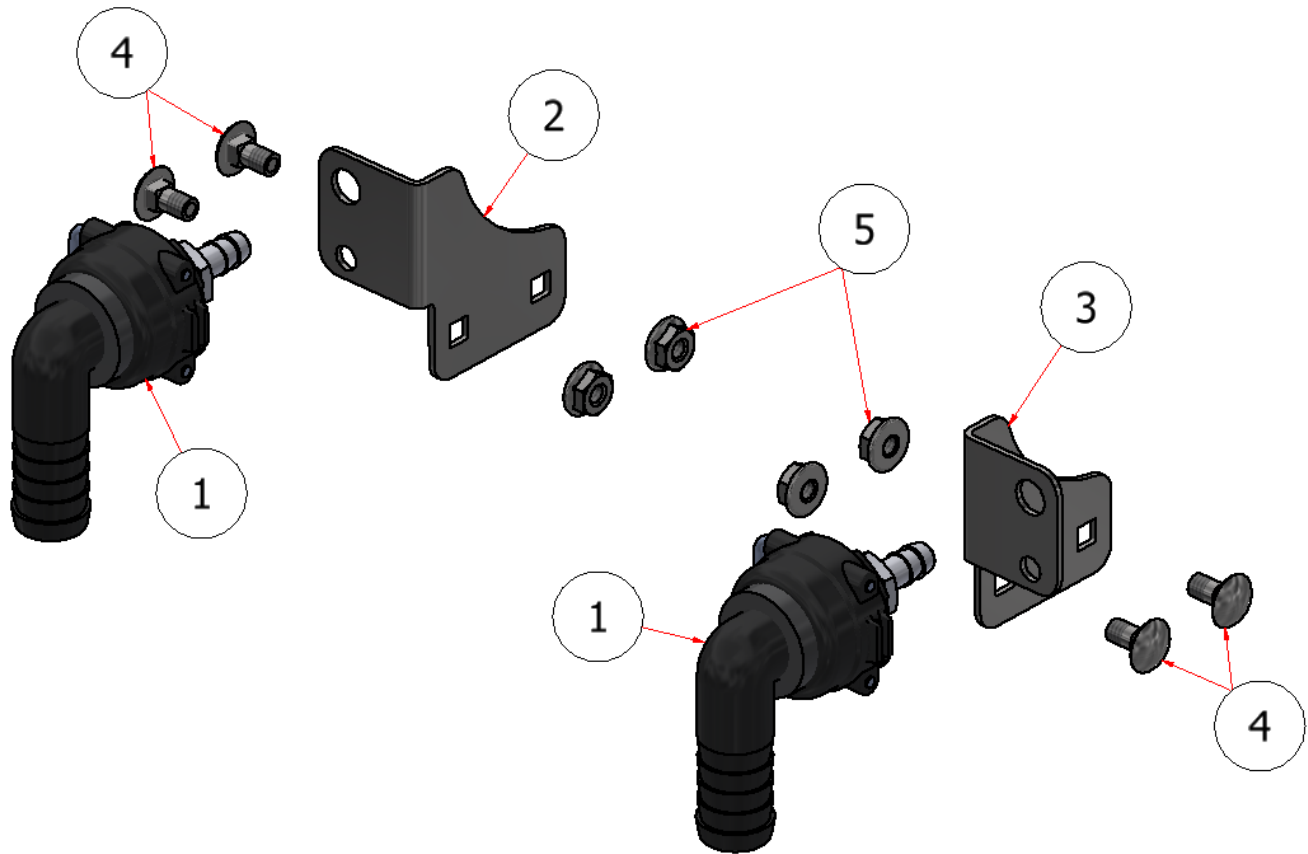

6 NOZZLE SPRAY BOOM DROPPER ASSY			
ITEM	QTY	PART NUMBER	DESCRIPTION
1	2	901699	DROPPER, FOAM MARKER
2	1	R22-149	BRACKET, FOAM MARKER, 6 NOZZLE BOOM
3	1	R22-149_MIR	BRACKET, FOAM MARKER, 6 NOZZLE BOOM, LEFT
4	4	CB-145SS	CARRIAGE BOLT, 1/4 X 1/2
5	4	HFNCS-14SS	HEX FLANGE NUT, 1/4-20

2.5 GAL. FOAM MARKER ASSEMBLY INSTRUCTIONS

STEP ONE: Disconnect the battery, *ground* first and then *power* wire.



GROUND

POWER

STEP TWO:

- Squeeze the hose clamp and slide it back.
- Disconnect both fuel lines.
- Remove the fuel tank.

ENGINE SUPPLY LINE

PRESSURE RELIEF



CAUTION!

- Beware of excess fuel in the lines.
- Fuel spillage.

WARNING!

- Flammable gas.

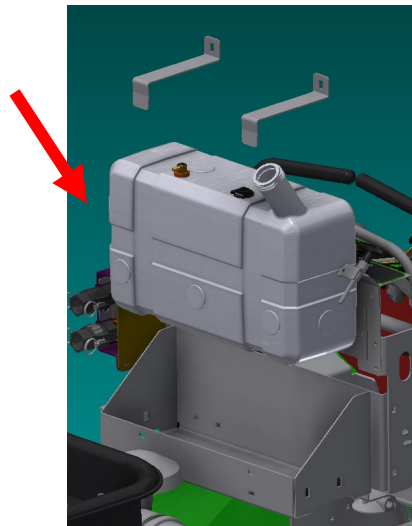

2.5 GAL. FOAM MARKER ASSEMBLY INSTRUCTIONS

STEP THREE:

Install the foam marker pump assembly.

NOTE: *If the machine is equipped with 35 gallon tank, see the next page for lower bracket assembly.*

- Attach the lower support bracket to the side of the hopper with 3/8" X 1" carriage bolts. (part shown below in purple)
- Attach the upper support bracket to the lower support bracket & the gas tank support. Lower bracket - 3/8" X 3/4", gas tank support - 1/4" X 3/4" carriage bolts.

NOTE: *Parts are shown in colors for clarity.*

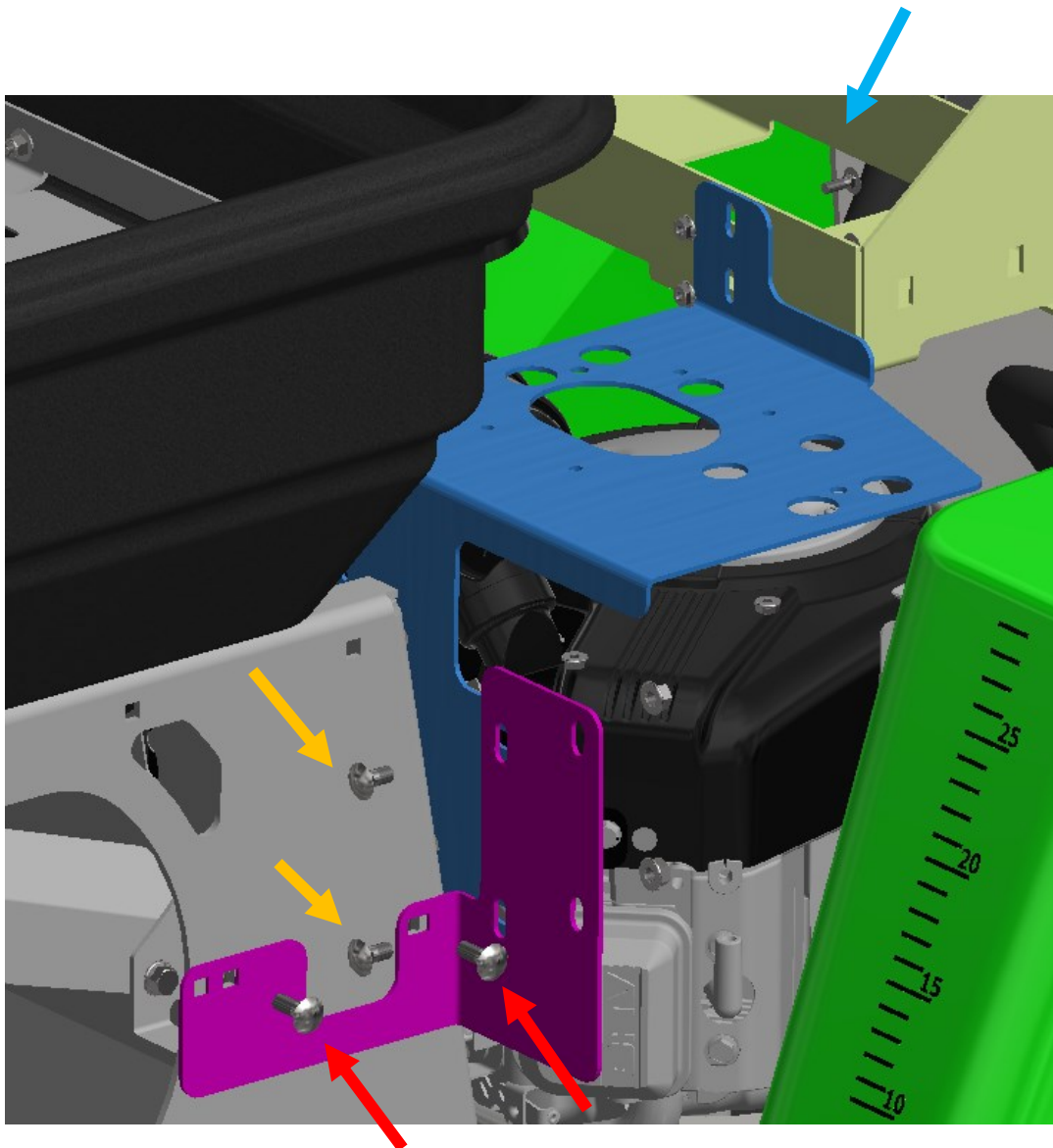

2.5 GAL. FOAM MARKER ASSEMBLY INSTRUCTIONS

35 GALLON TANK ATTACHMENT

- Attach the lower support bracket to the back of the 35 gallon tank frame with 3/8" X 1" carriage bolts.
- Attach the upper support bracket & the gas tank support. Lower bracket - 3/8" X 3/4", gas tank support - 1/4" X 3/4" carriage bolts.

NOTE: *Parts are shown in colors for clarity.*

35 GALLON TANK LOWER SUPPORT (R22-159)

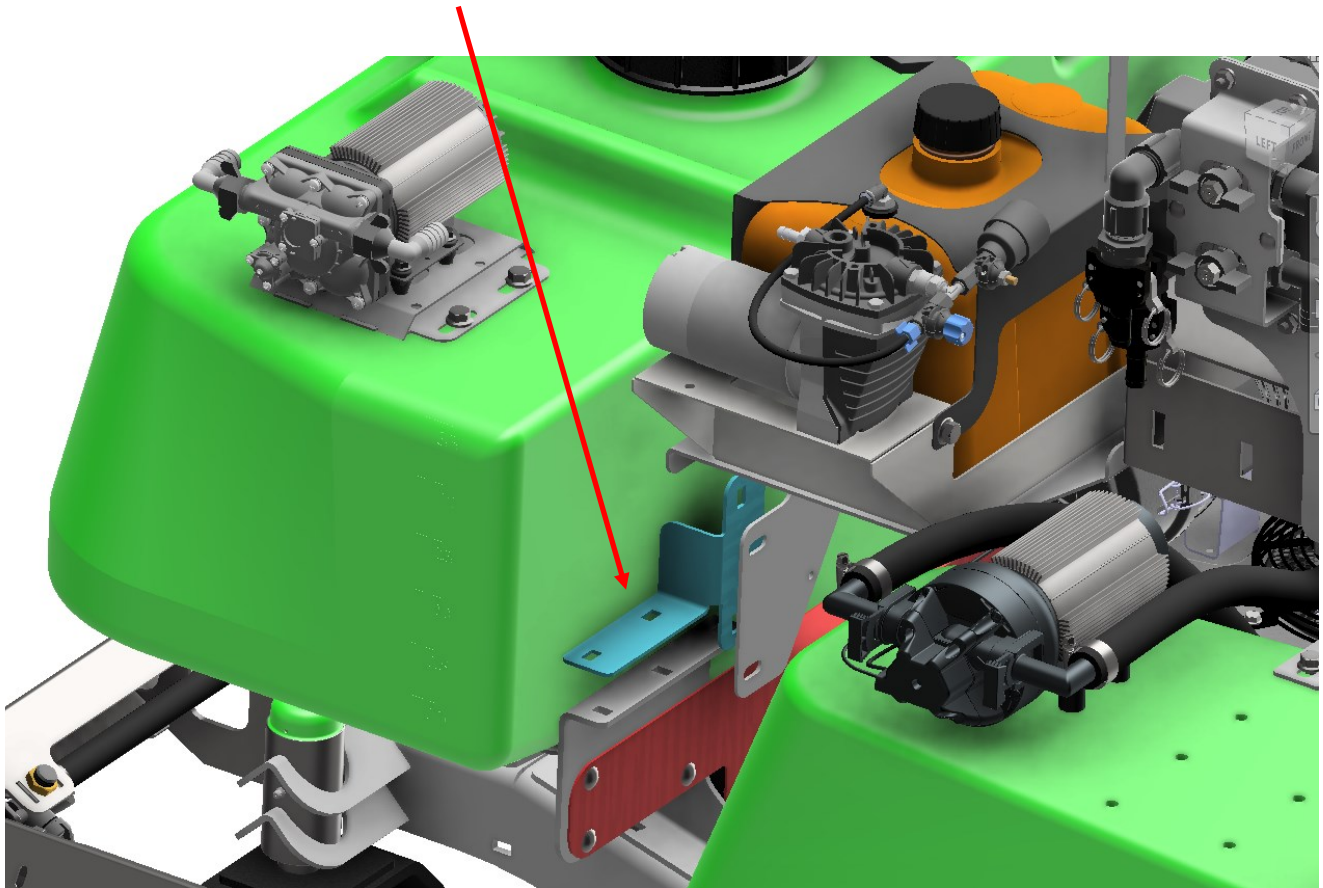

2.5 GAL. FOAM MARKER ASSEMBLY INSTRUCTIONS

- Attach the foam marker assembly to the support bracket (2) 1/4" X 1/2" carriage bolts.

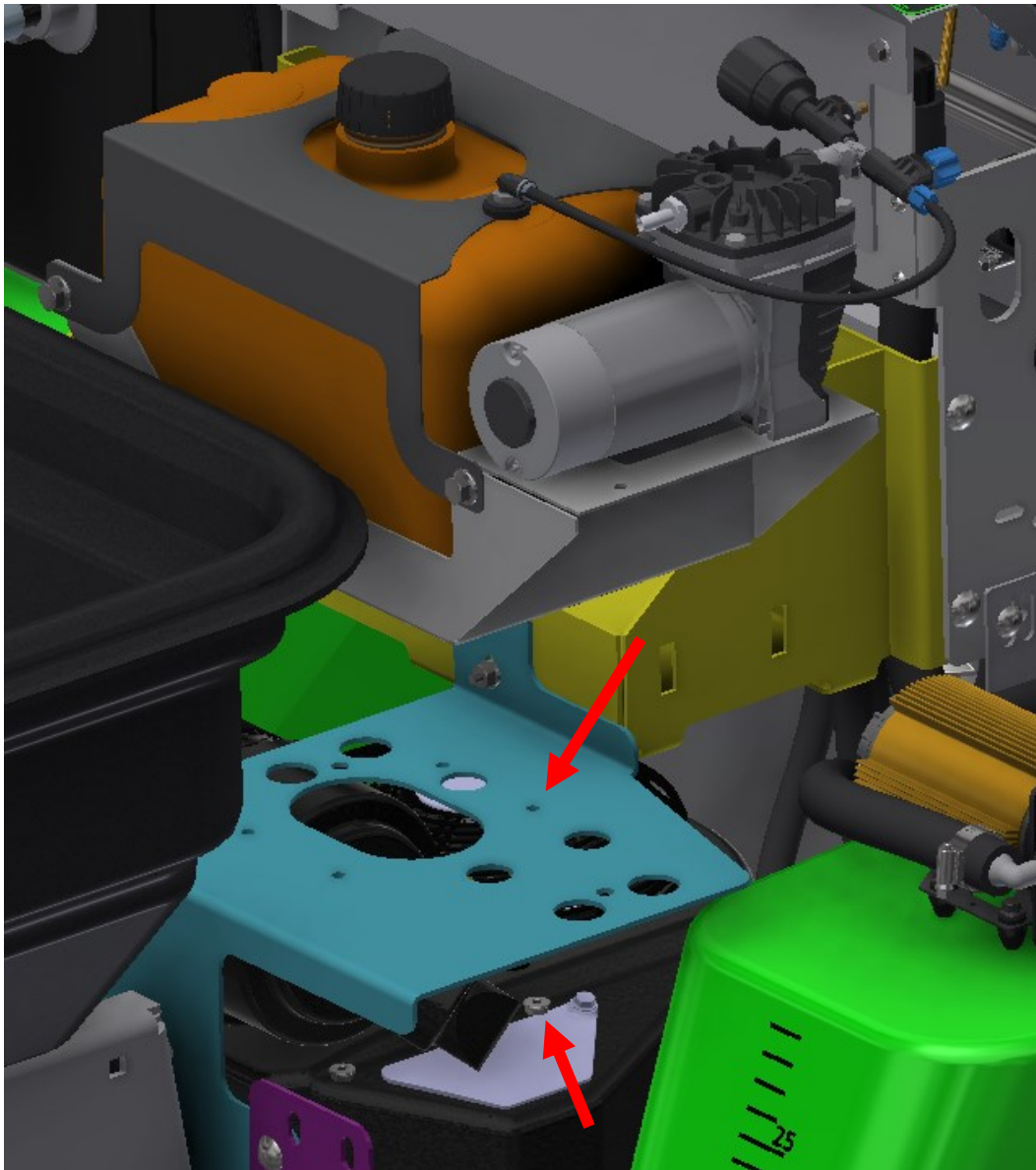

2.5 GAL. FOAM MARKER ASSEMBLY INSTRUCTIONS

STEP FOUR:

- Connect one end of the 3/8" hose to barb fitting on the motor.

A

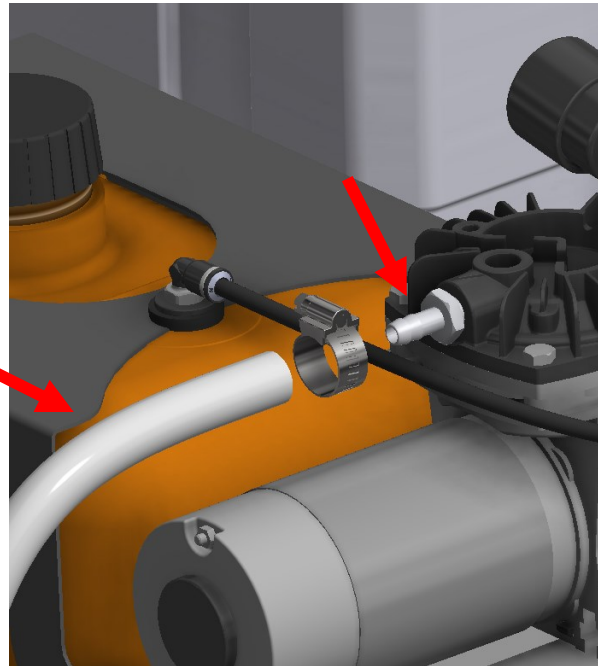

- Route the hose down and along the inside of the hopper.
- Zip tie the hose to the support bracket.

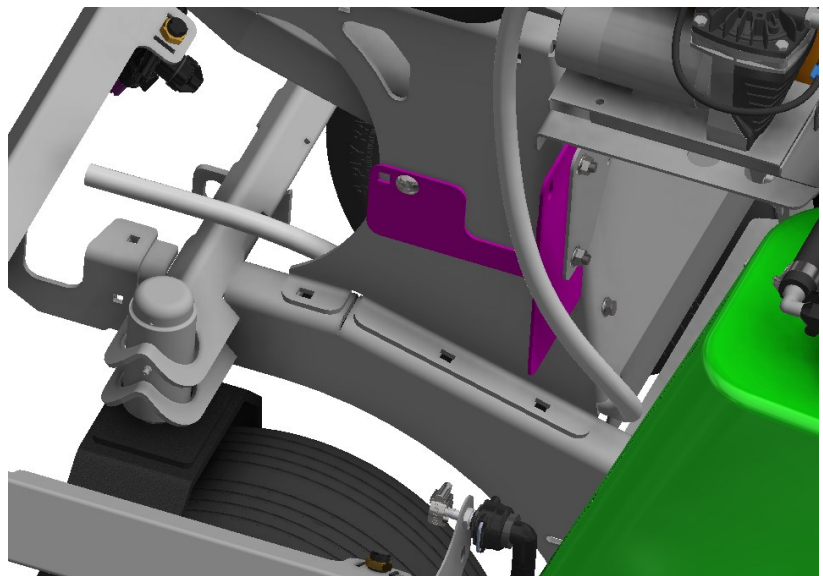
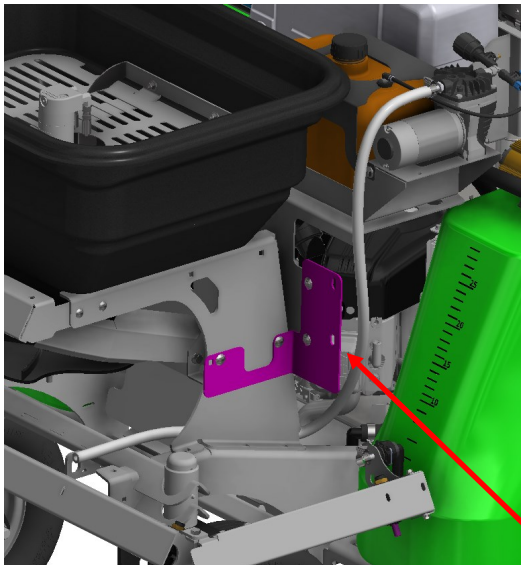

Zip tie

2.5 GAL. FOAM MARKER ASSEMBLY INSTRUCTIONS

STEP FIVE:

- Connect the other end of the 3/8" hose to the barb tee fitting.

A

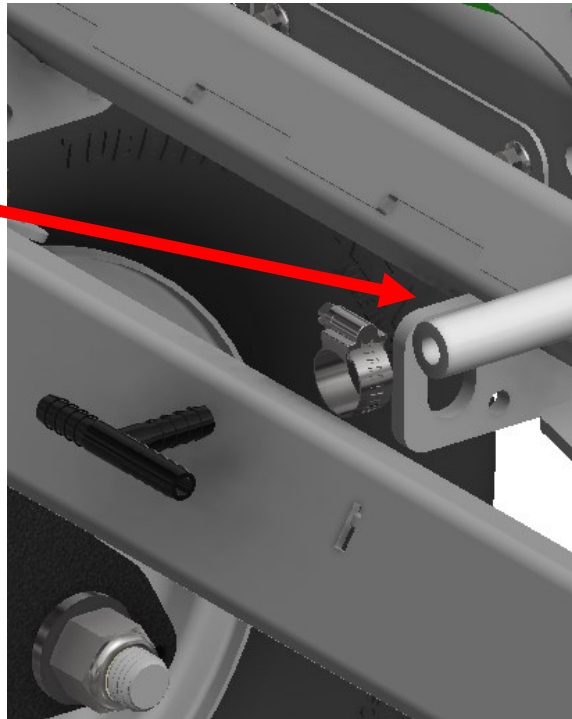

STEP SIX:

- Attach the foam marker bracket to the end of the boom.

NOTE:

- *Repeat step four for the other side of the boom.*
- *Note the orientation of the bracket for left and right side.*

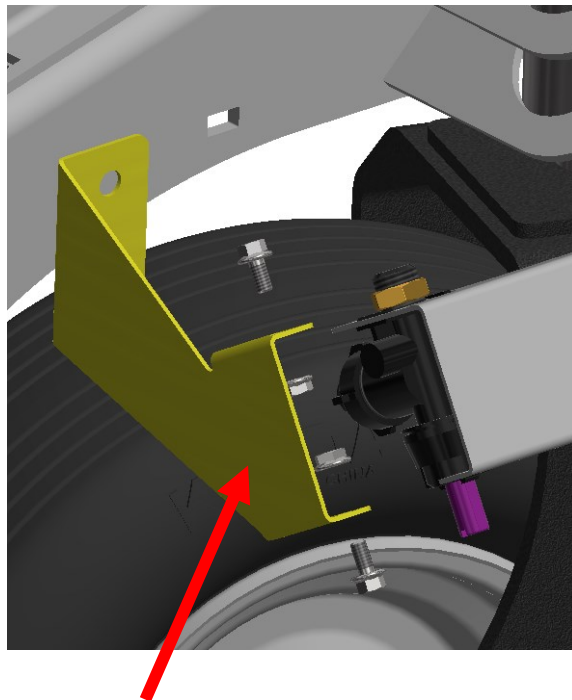

RIGHT SIDE

2.5 GAL. FOAM MARKER ASSEMBLY INSTRUCTIONS

- Attach the foam marker bracket to the end of the boom.

NOTE:

- *Repeat this step for the other side.*
- *Note the orientation of the bracket for left and right side.*

Fig. 1

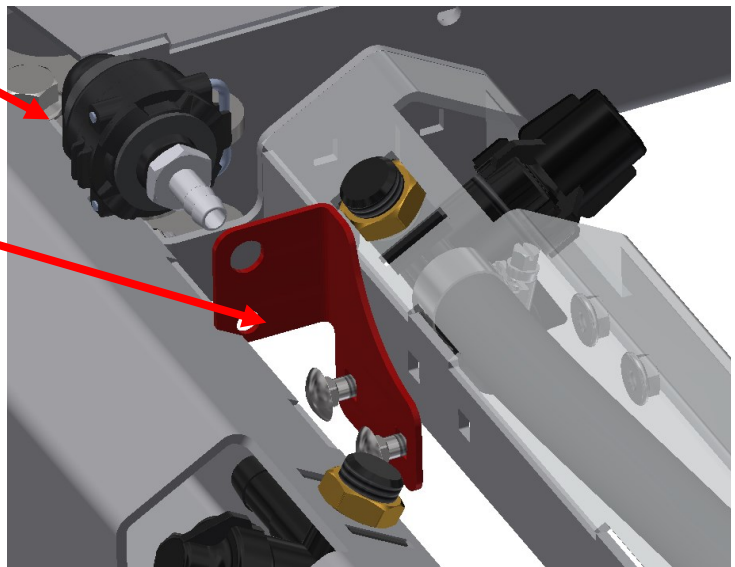

6 NOZZLE BOOM OPTION

LEFT SIDE

2.5 GAL. FOAM MARKER ASSEMBLY INSTRUCTIONS

STEP SEVEN: *LEFT SIDE*

- Attach the foam marker dropper to the bracket, securing it with 3/8" hose and hose clamp.

NOTE: *Instructions are the same for the 6 nozzle spray boom (see Fig. 1 page 11).*

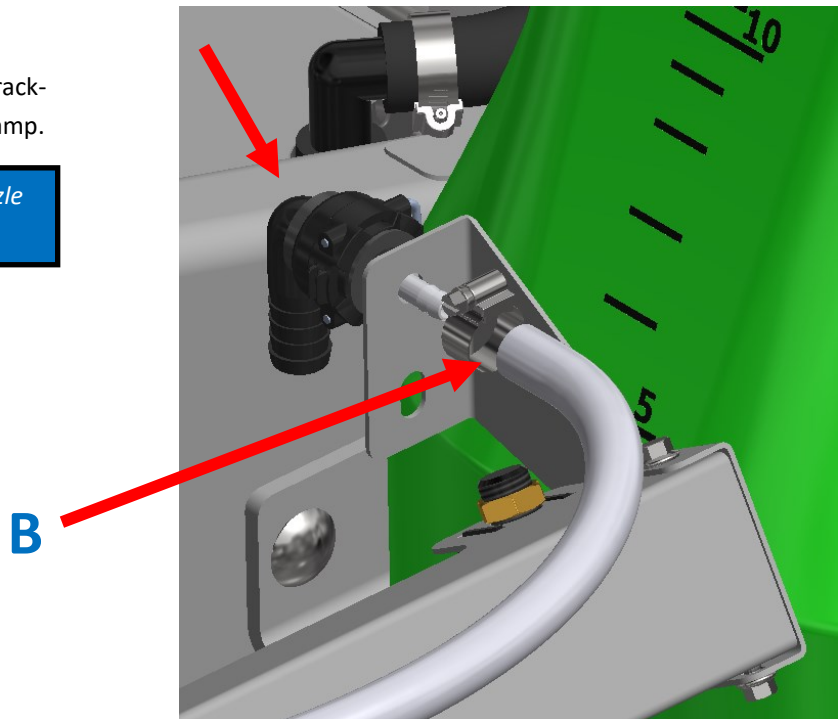

- Connect the other end of the hose to the 3/8" hose barb tee fitting, securing it with 3/8" hose clamp.

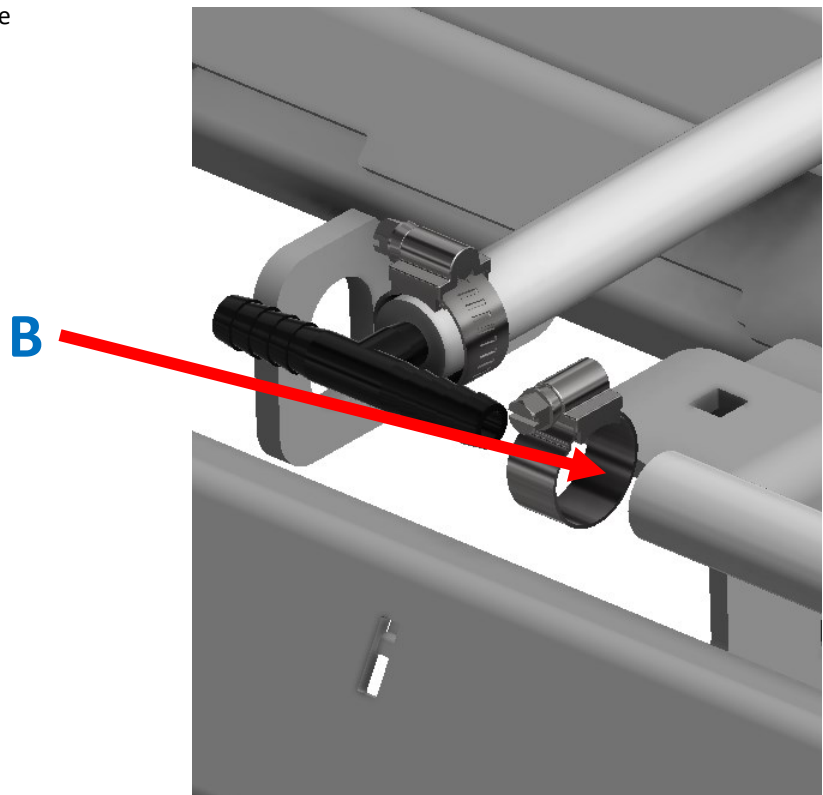

2.5 GAL. FOAM MARKER ASSEMBLY INSTRUCTIONS

STEP EIGHT: **RIGHT SIDE**

- Attach the foam marker dropper to the bracket, securing it with 3/8" hose and hose clamp.

NOTE: Instructions are the same for the 6 nozzle spray boom, both sides (see Fig. 1 page 11).

C

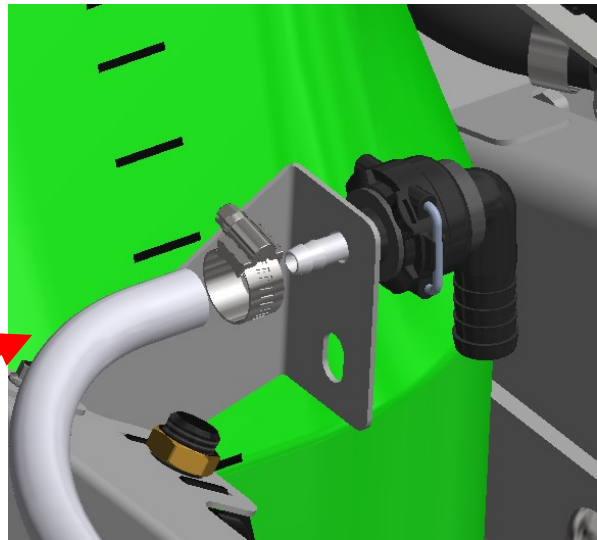

- Connect the other end of the hose to the 3/8" hose barb tee fitting, securing it with 3/8" hose clamp.

C

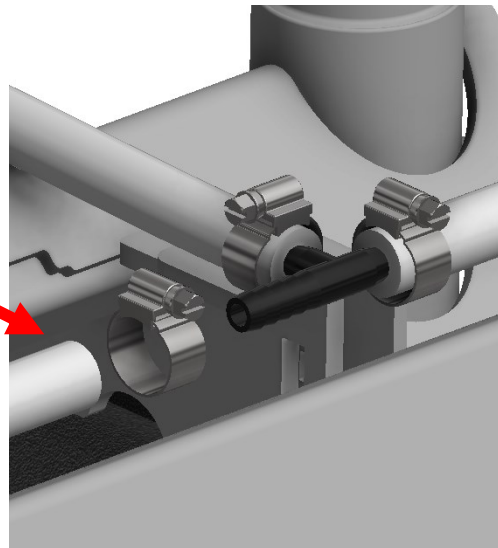

2.5 GAL. FOAM MARKER ASSEMBLY INSTRUCTIONS

WIRING HARNESS

SG-7G1

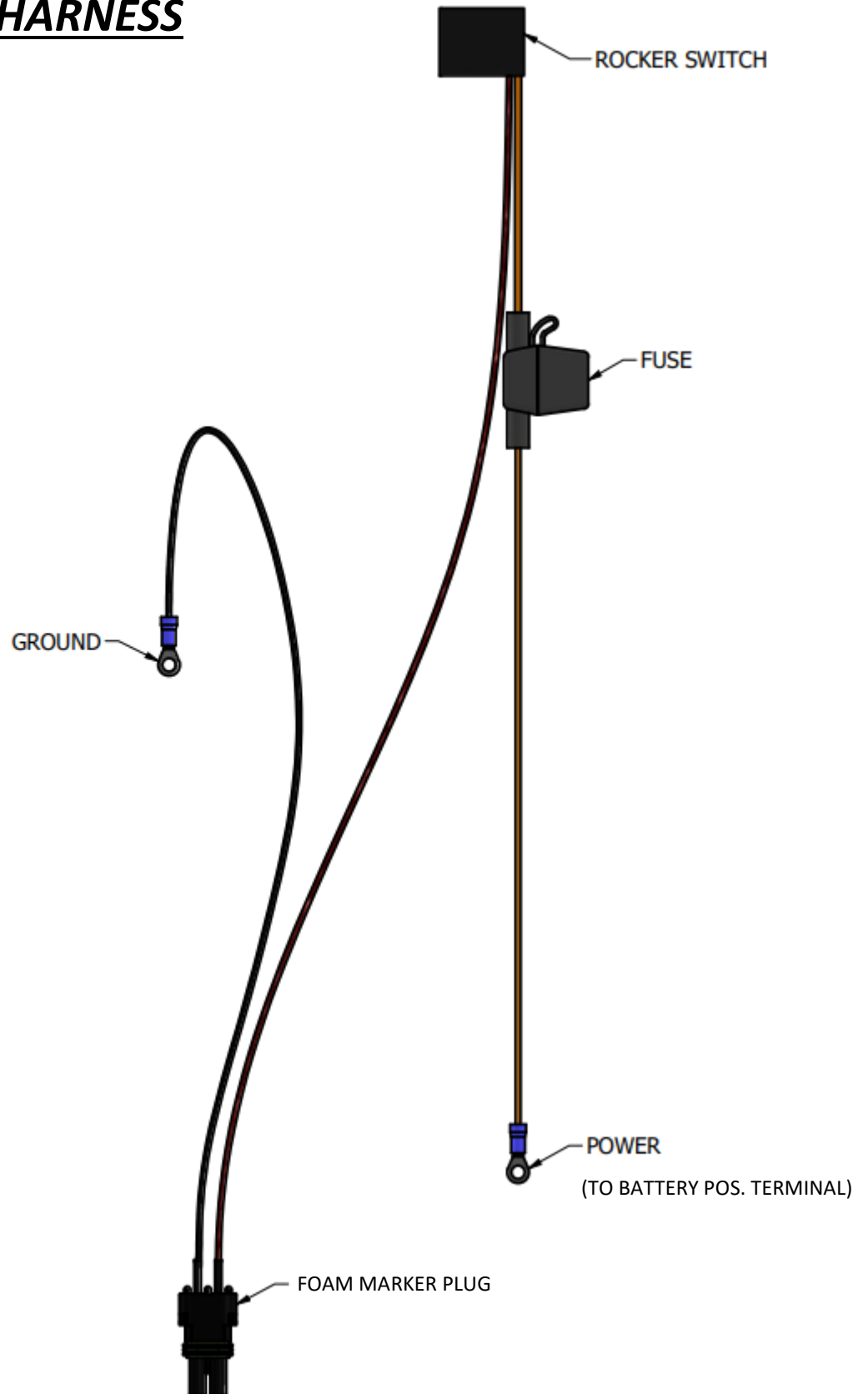

2.5 GAL. FOAM MARKER ASSEMBLY INSTRUCTIONS

STEP NINE:

- Remove the plastic cap from “aux 3” in the panel .
- Attach the “rocker switch” to the dash panel.

NOTE: *The long side of the rocker switch should face down.*

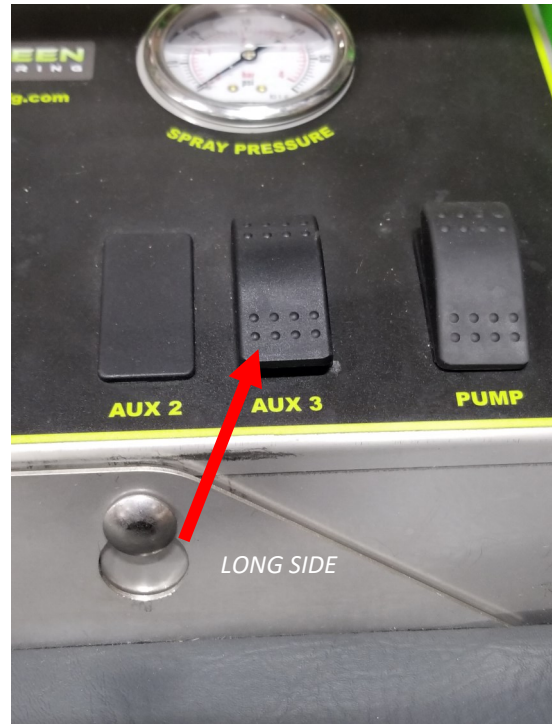

- Plug the wiring harness into the rocker switch.

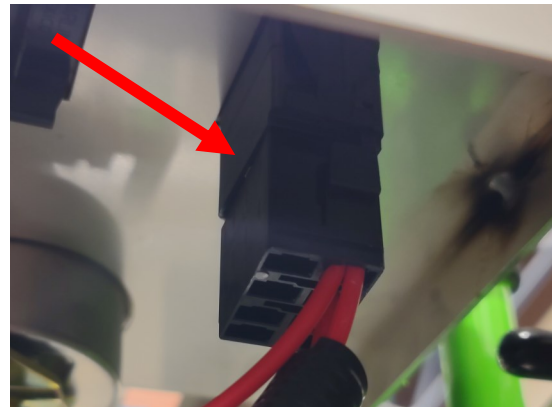

2.5 GAL. FOAM MARKER ASSEMBLY INSTRUCTIONS

STEP TEN: Continue to route the wiring harness down through the uprights attaching it with zip ties as necessary.

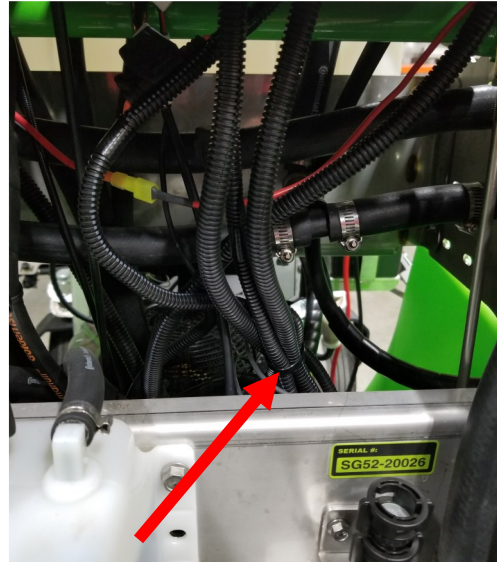

STEP ELEVEN:

- Connect the ground wire from the wiring harness to the up right cross member.
- Route the power wire neatly down and along the frame to the battery.

NOTE: Do not connect the *Power wire* until all connections are made, (see step fourteen)

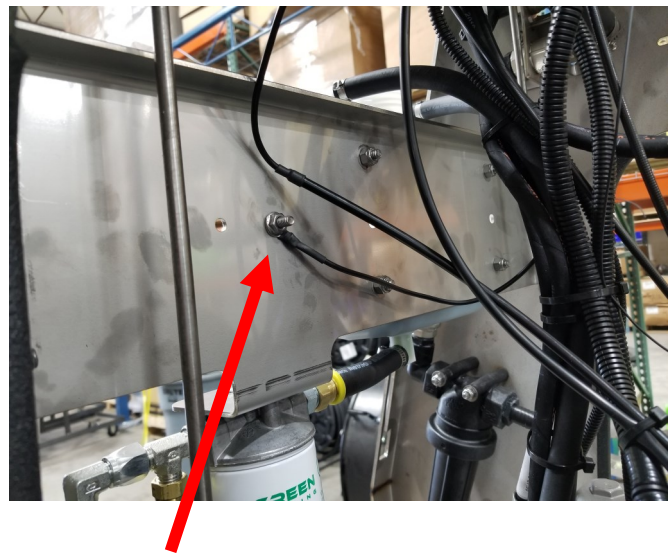

STEP TWELVE: Plug the pump power connector from the harness to the foam marker power connector.



2.5 GAL. FOAM MARKER ASSEMBLY INSTRUCTIONS

STEP THIRTEEN:

- Reinstall the fuel tank.
- Squeeze the hose clamp and slide it back.
- Reconnect both fuel lines.

CAUTION!

- Beware of excess fuel in the lines.
- Fuel spillage.

WARNING!

- Flammable gas.

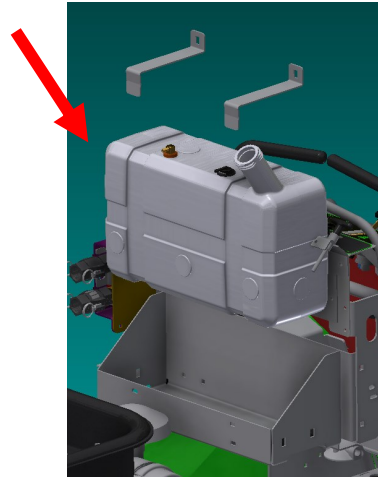

ENGINE SUPPLY LINE

PRESSURE RELIEF



STEP FOURTEEN: Reconnect the battery *power wire* first along with the *yellow power wire* from the wiring harness, and then reconnect the *ground wire*.



2.5 GAL. FOAM MARKER ASSEMBLY INSTRUCTIONS

OPERATION

FILLING THE TANK

CAUTION!

- *Wear safety goggles & all proper clothing when operating, servicing or refilling this machine.*
- *Always read & follow manufactures recommendations when handling any chemical.*
- *Do not pump combustible liquids or vapors with this product.*
- *When filling the tank, add WATER FIRST and then FOAMING AGENT.*

- Be sure the power is off and remove the cap from the top of the tank.
- Starting with a small amount of water (2 gal.), mix the foam concentrate according to the label directions on the foaming agent. If considerably more concentrate is needed above the manufacturer's suggested ratio (usually 2-5 ounces per gallon) to produce good foam, use of a softener or soft water may be required. If the foam is too stiff or (dry), it may surge out at irregular intervals. Under this condition. Add water until the foam becomes more wet.
- Replace the cap on the tank.

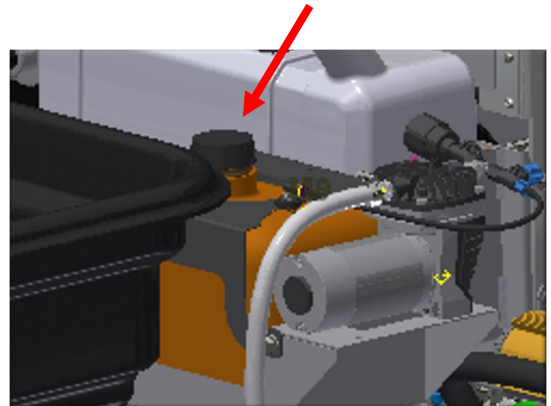

NOTE: *Mixing foam takes some experience. Different water sources may require different amounts of concentrate to obtain the desired foam density. Water hardness, pH, and impurities will affect the rate of concentrate required for a consistent, long-lasting foam.*

Different conditions may require different mixing ratios to produce desirable results. It's worthwhile to determine the proper foam/water mixing ratio for your water source with the initial filling. Doing so will save time in the future and aid in consistent foam quality.

If hard water is a problem, commercial softening agents are available. You can make your own softening agent by dissolving a commercial water softening powder (available at most grocery stores) in hot water and adding a portion of the mixture to your tank each time you fill. Experimentation will reveal the correct amount to use. A good starting point is 1-1/2 ounces per gallon of water.

Mix ratios for foam concentrates advertised as 80:1 or 160:1 must be adjusted for use with your water. Such ratios are only a guideline.

Heat, humidity, & wind will also affect the life of the foam. Using a good quality marking agent, such as RUNWAY, may be very important. Liquid dish detergent also works in the foam marker system. You will have to experiment with detergents before using on any special turf applications.

2.5 GAL. FOAM MARKER ASSEMBLY INSTRUCTIONS

- Start the machine and activate the foam marker and let it prime until it starts dropping suds.

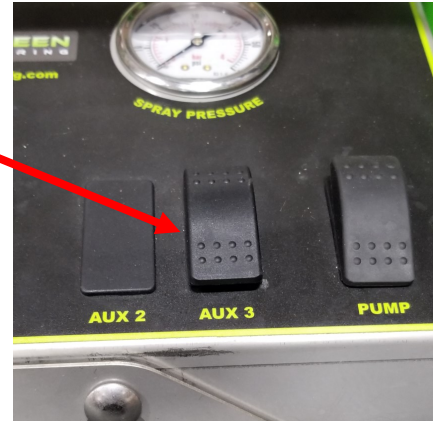

- Turn the foam marker and machine off, Adjust the foam marker for desired timing.

A - Flow control valve, adjust the flow control valve for more or less flow.

B - Air valve.

NOTE: *The air valve is factory preset.*

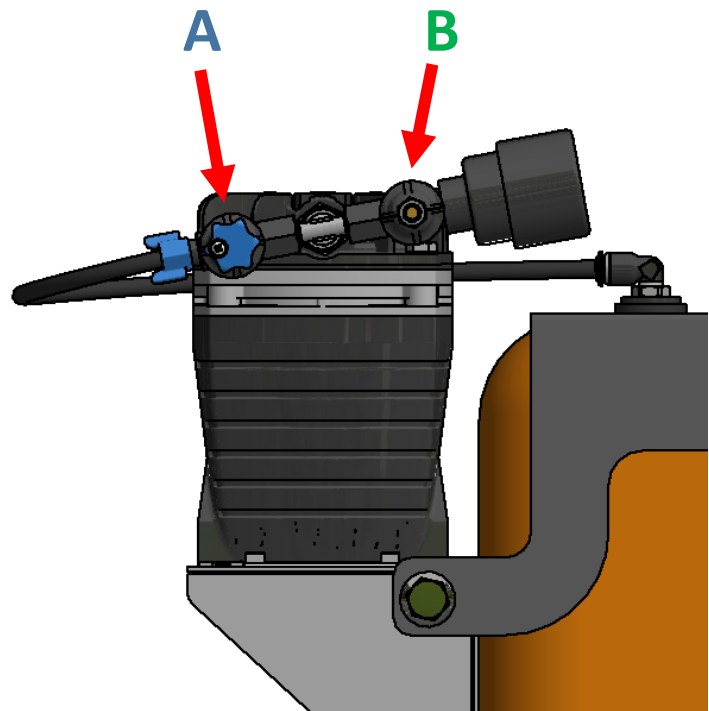

2.5 GAL. FOAM MARKER ASSEMBLY INSTRUCTIONS

TROUBLE SHOOTING

PROBLEM	SOLUTION
NOT ENOUGH FOAM	<ul style="list-style-type: none">• ADD MORE FOAM CONCENTRATE TO THE TANK.• CHECK FOR HOLES IN THE AIR LINE.• CHECK FOR PINCHED AIR OR LIQUID LINES.• CLEAN SCREEN-STRAINER/FOAM HEAD.• ADJUST THE LIQUID FLOW CONTROL VALVE.
WET FOAM	<ul style="list-style-type: none">• ADD MORE FOAM CONCENTRATE TO THE TANK.• CLEAN SCREEN-STRAINER/FOAM HEAD.• REDUCE LIQUID FLOW
FOAM IS SURGING	USE LESS CONCENTRATE.
FOAM DOES NOT LAST LONG ON THE GROUND	<ul style="list-style-type: none">• ADD MORE FOAM CONCENTRATE TO THE TANK.• USE A HIGH QUALITY FOAM CONCENTRATE LIKE RUNWAY.• USE COLLECTOR HEADS.
BLOWING FOAM IN WINDY WEATHER	<ul style="list-style-type: none">• USE LESS CONCENTRATE TO MAKE WETTER FOAM.• ADD MORE WATER TO FOAM SOLUTION• INCREASE THE LIQUID FLOW.



Steel Green Mfg.
824 S State Road 39
Lebanon, IN 46052
(765)-481-2890
www.steelgreenmfg.com

MANUAL PART NO.	MANUAL REV.	DESCRIPTION	KIT PART NO.
SGM-003	D	2.5 GALLON FOAM MARKER SG46/52 KIT	K299501