



INSTRUCTION MANUAL

SNOW PLOW ATTACHMENT

Models: SG36, SG42, SG46, & SG52



SNOW PLOW KIT INSTRUCTIONS

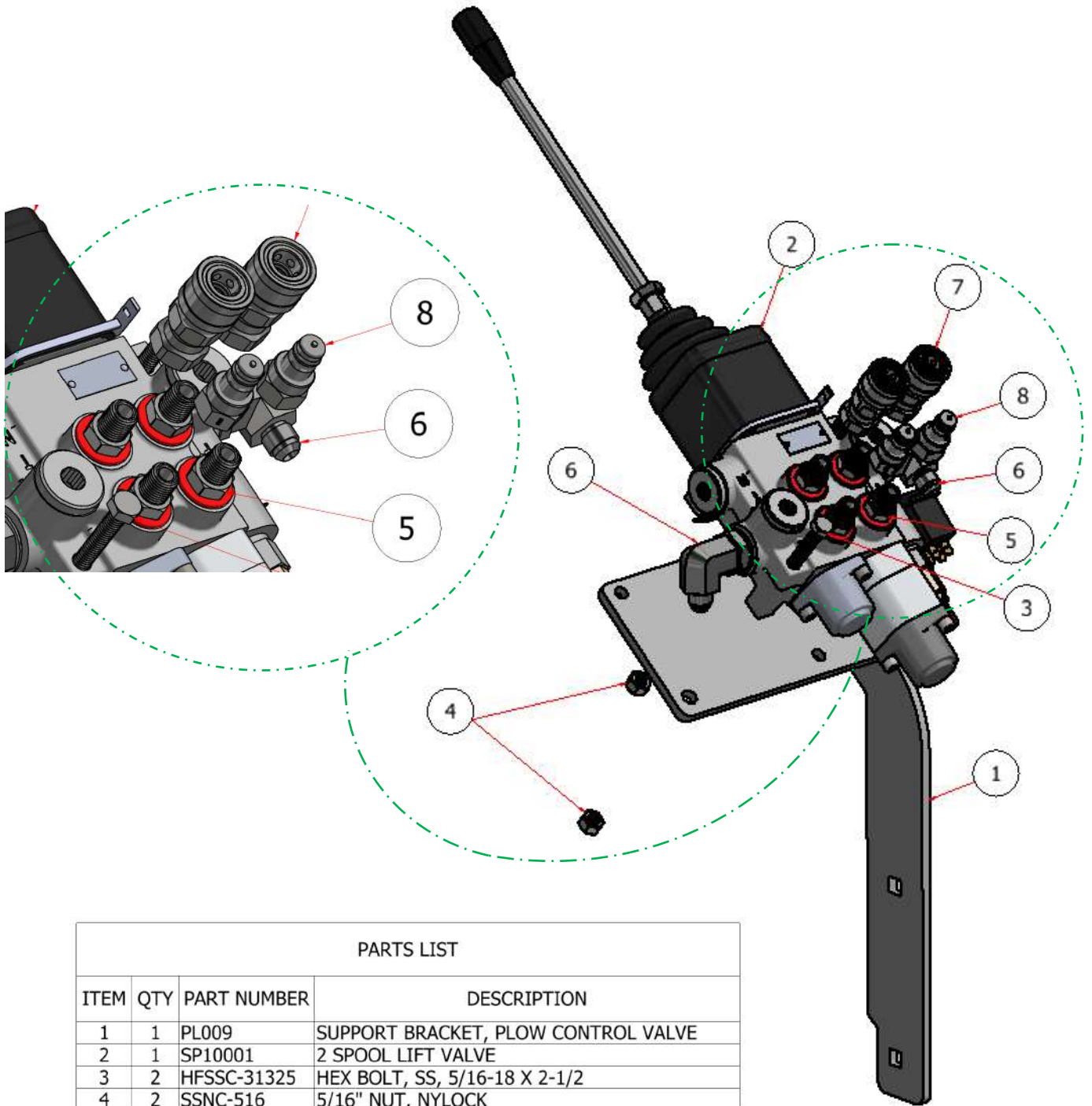

PARTS LIST			
ITEM	QTY	PART NUMBER	DESCRIPTION
1	1	PL009	SUPPORT BRACKET, PLOW CONTROL VALVE
2	1	SP10001	2 SPOOL LIFT VALVE
3	2	HFSSC-31325	HEX BOLT, SS, 5/16-18 X 2-1/2
4	2	SSNC-516	5/16" NUT, NYLOCK
5	4	H84071	FITTING, 1/2 MORB X 1/4 MNPT
6	2	H84070	FITTING 5/8 MORB X 3/8 MJIC 90
7	4	H85010	QUICK DISCONNECT, 1/4, FEMALE
8	4	H85011	QUICK DISCONNECT, 1/4, MALE

SNOW PLOW KIT INSTRUCTIONS

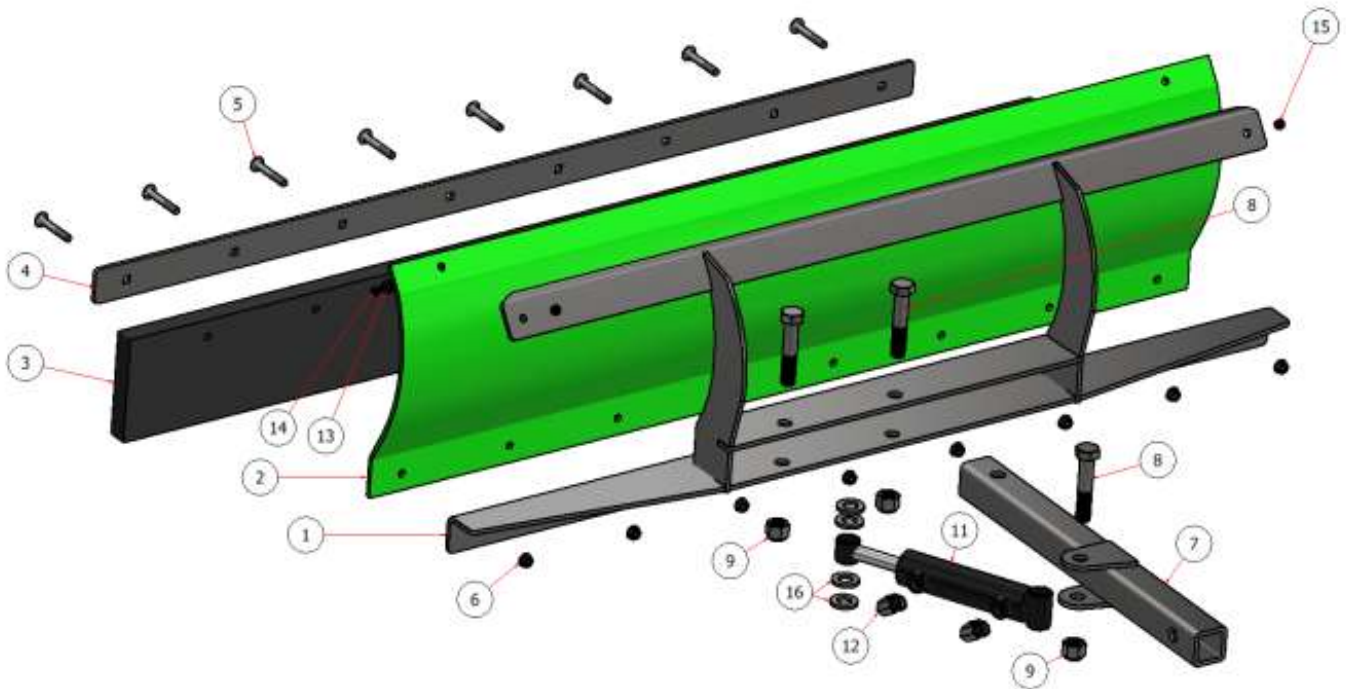

SNOW PLOW PARTS LIST			
ITEM	QTY	PART NUMBER	DESCRIPTION
1	1	W-PL001	FRAME, SNOW PLOW
2	1	SP10005	SKIN,PLOW
3	1	SP10006	CUTTING EDGE, RUBBER
4	1	PL002	EDGE CAP, PLOW
5	8	CB.375-16X2.5	CARRIAGE BOLT 3/8" X 2.5"
6	8	HFNCS-38S	HEX FLANGE NUT - 3/8-16
7	1	PL016	ATTACHMENT ARM, SNOW PLOW
8	3	HFB .750-10X3.75	HEX BOLT, 3/4 X 3.75
9	3	SSNNC-34	NYLOCK, SS - 3/4-10
11	1	SP10003	CYLINDER, HYDRAULIC, 1.5 X 4 X .75
12	2	SG-K10007-SPHK	3/8" MNPT X 1/4" FNPT SWIVEL 90
13	2	SP10007	WASHER,PLASTIC, 1/4"
14	2	PTSS-141	BOLT,BUTTON HEAD 1/4" X 1"
15	2	SSNNC-14	NYLOCK, SS - 1/4-20
16	4	FWSS-34	FLAT WASHER, SS - 3/4

SNOW PLOW KIT INSTRUCTIONS

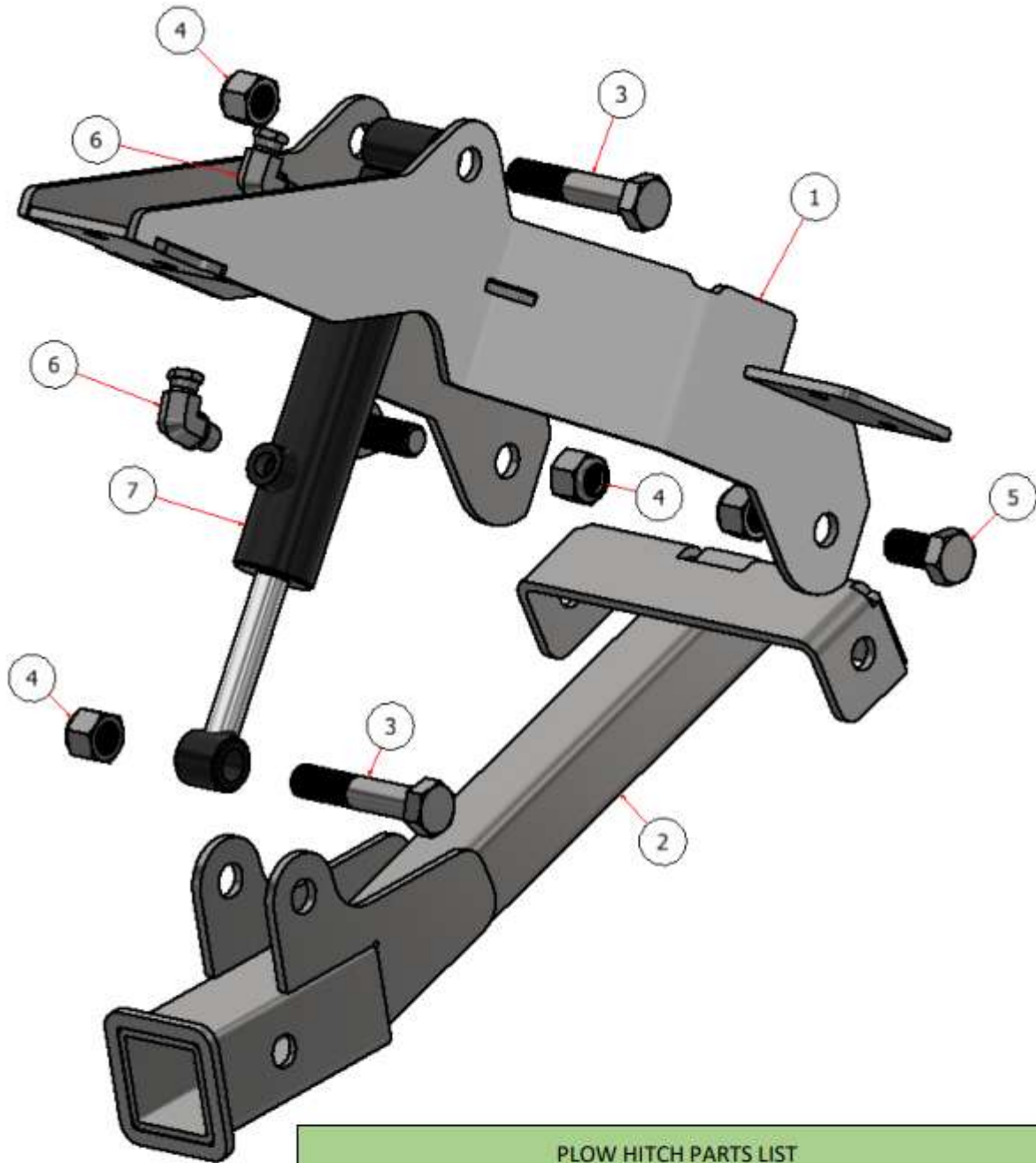

PLOW HITCH PARTS LIST			
ITEM	QTY	PART NUMBER	DESCRIPTION
1	1	W-PL007	PLOW HITCH, UPPER
2	1	W-PL004	PLOW HITCH, LOWER
3	2	HFB .750-10X3.75	HEX BOLT, 3/4 X 3.75
4	5	SS NYLOCK .750-10	HEX NUT, 3/4 NYLOCK SS
5	2	HFB .750-10X1.5	HEX BOLT, 3/4 X 1.5
6	2	SG-K10007-SPHK	3/8" MNPT X 1/4" FNPT SWIVEL 90
7	1	SP10002	CYLINDER, HYDRAULIC, 1.5 X 6 X .75

SNOW PLOW KIT INSTRUCTIONS

STEP ONE:

NOTE:

- If your machine is already equipped with the hydraulic lift kit (A10081) proceed to step eight.
- Some parts not shown for clarity.

- Set the plow hitch in the frame by resting the front of the plow hitch on top of the frame rail and the back of the hitch will attach to the bottom of the frame rail.

ASSEMBLY TIP: Use a floor jack or block of wood to support the back of the plow hitch.

- Attach the plow hitch to the frame using the top brackets and (6) CB-375275 3/8" X 2-3/4" carriage bolts and (6) SSNNC-38 3/8" nuts provided with the kit.

NOTE: Note the orientation of the back brackets. Be sure the tab is facing the correct direction (One will face left and the other will face right) so the hitch is centered in the frame.

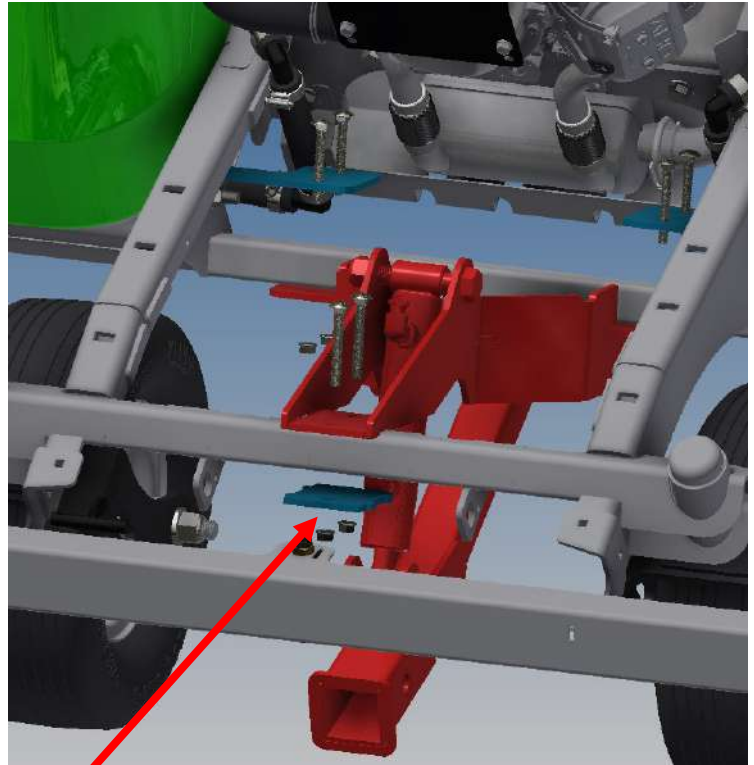

PL003 FRONT BRACKET

PL005 REAR BRACKET

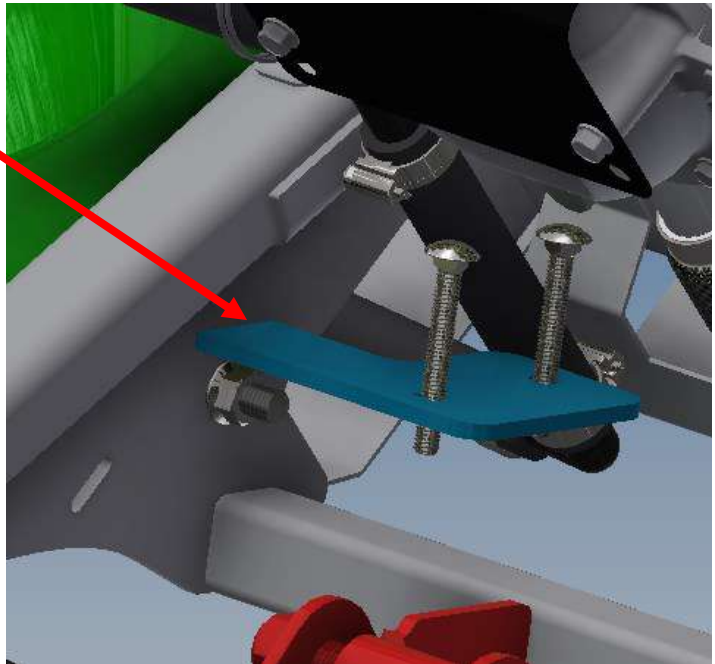

SNOW PLOW KIT INSTRUCTIONS

- After the hitch is tightened to the frame adjust the exhaust shield so it rests in the grooves of the plow hitch.

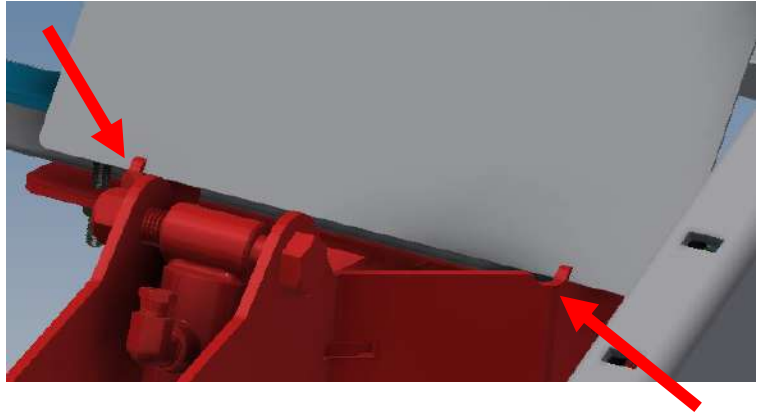

STEP TWO:

- Remove the existing (2) bolts from the gas tank support.

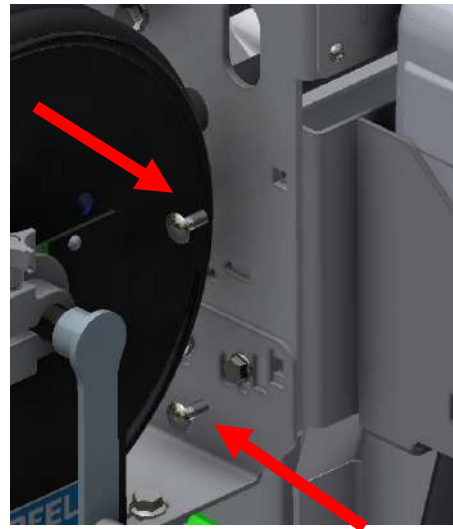

- Attach the control valve assembly to the side of the upright using (2) 3/8 X 1" carriage bolts provided with the kit and reuse the nuts that were removed.

NOTE:

- *If your machine is equipped with an "all liquid" tank and is the Steel Green current design (pictured below). You can move the valve assembly to the other side of the upright.*
- *If your machine is equipped with the old valve design, you can purchase the updated brackets.*

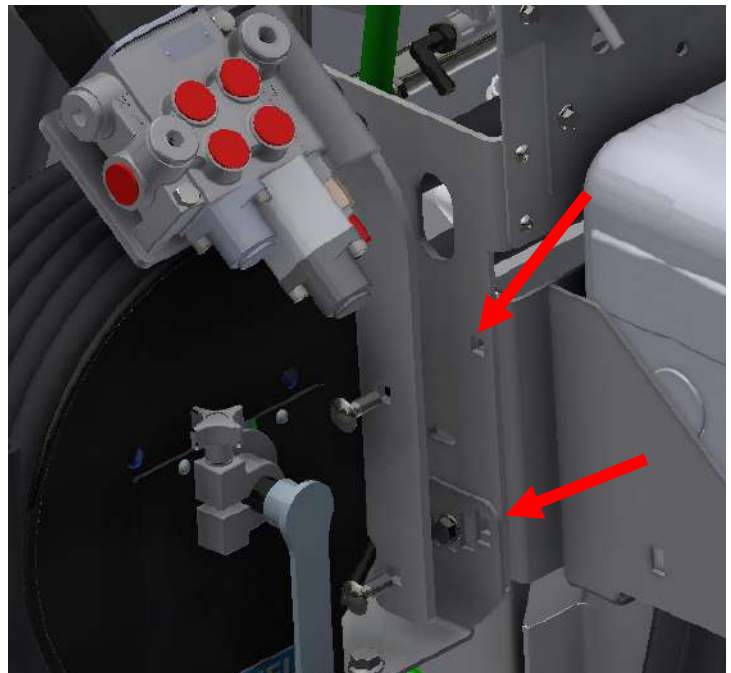

SNOW PLOW KIT INSTRUCTIONS

NOTE: Before starting the following steps, drain the hydraulic oil from the machine. Refer to Steel Green Hydraulic oil change manual.

WARNING!

Connecting the hoses incorrectly will blow the seals out of the snow plow valve & void the Steel Green Warranty.

STEP THREE:

- Locate the hose that runs from the bottom port of the hopper control valve down to the left pump.
- Disconnect each end of the hose and use the (2) 1/4" jic red plugs provided with the kit to cap the ends of the hose.

NOTE: Leave the hose zip tied in the bundle and tuck the ends out of the way.

TIP: Disconnect the end from the hopper control valve first and hold the end of the hose up to prevent excess oil spillage. Then turn the end down into a container to drain the rest of the excess oil. Have a rag and or container ready to catch excess oil.

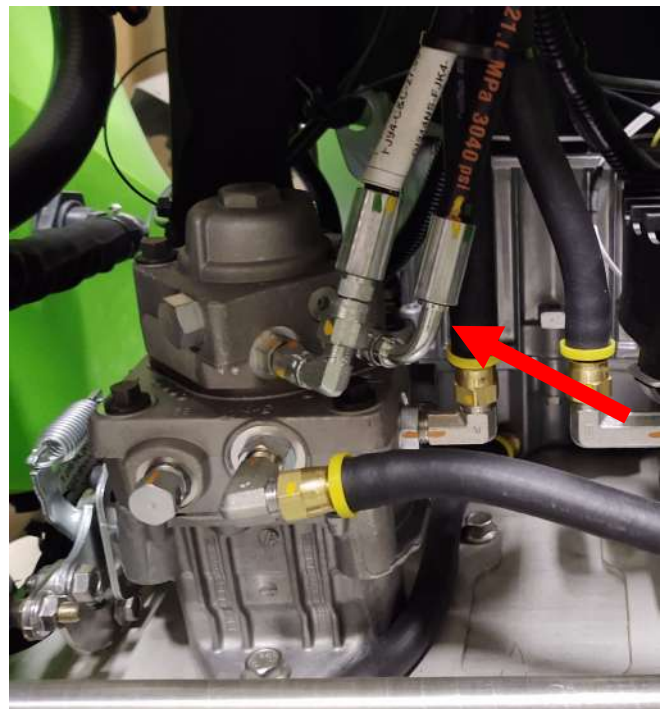
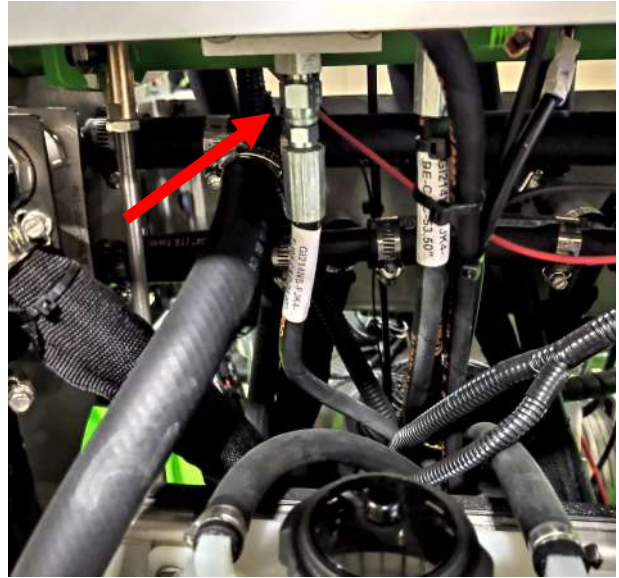

SNOW PLOW KIT INSTRUCTIONS

NOTE: *If your machine is equipped with a Hill Side Assist system, Proceed to Page 10.*

STEP FOUR:

- Using (1) of the 38" hoses provided with the kit, attach the end with the straight fitting to the return port of the control valve.

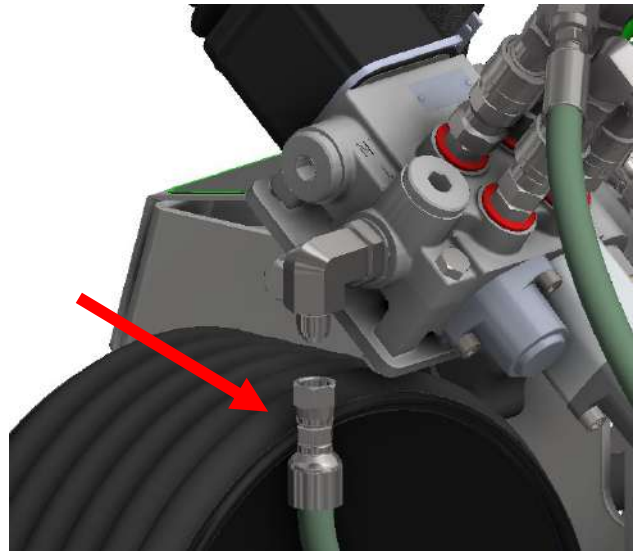

- Attach the other end of the hose to the input port of the hopper control valve. *(end with 90° fitting)*

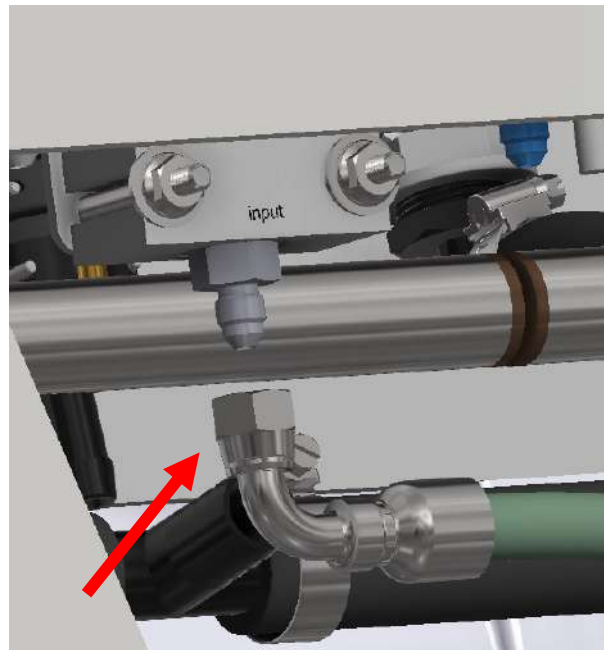

SNOW PLOW KIT INSTRUCTIONS

STEP FIVE:

- Using the other 38" hose provided with the kit, attach the end with the straight fitting to the supply port of the control valve.

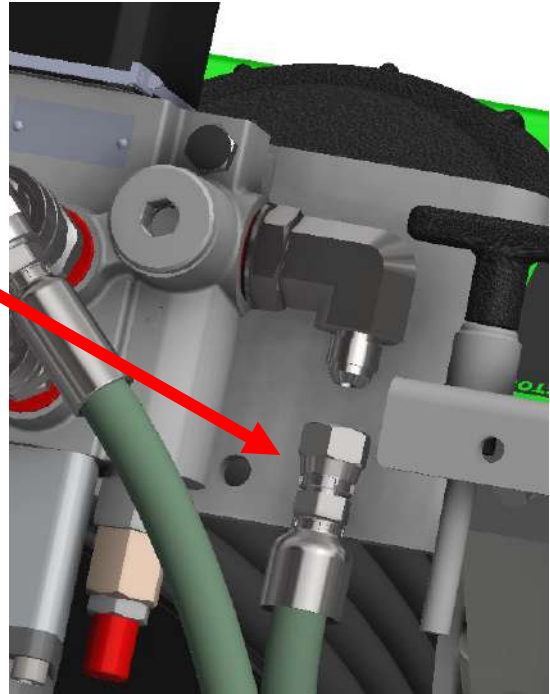

- Attach the other end of the hose to the hydraulic pump. (*end with 90° fitting*)

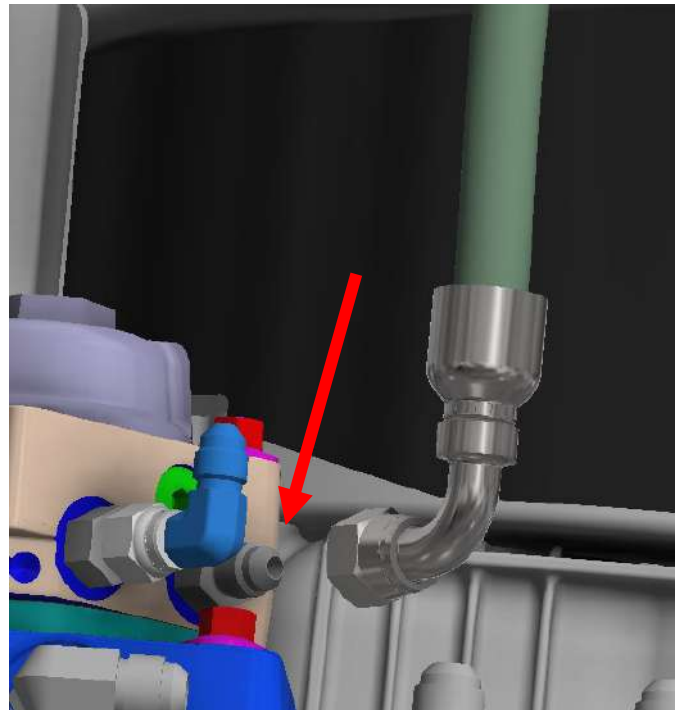

SNOW PLOW KIT INSTRUCTIONS

NOTE:

- *Some parts not shown for clarity.*
- *Before starting the following steps, remove the supply hose from the Hill Side Assist system. Refer to the Steel Green HSA manual.*

STEP FOUR: (HSA)

- Using a 38" hose provided with the kit, attach the end with the 90° fitting to the tee fitting hydraulic control valve.

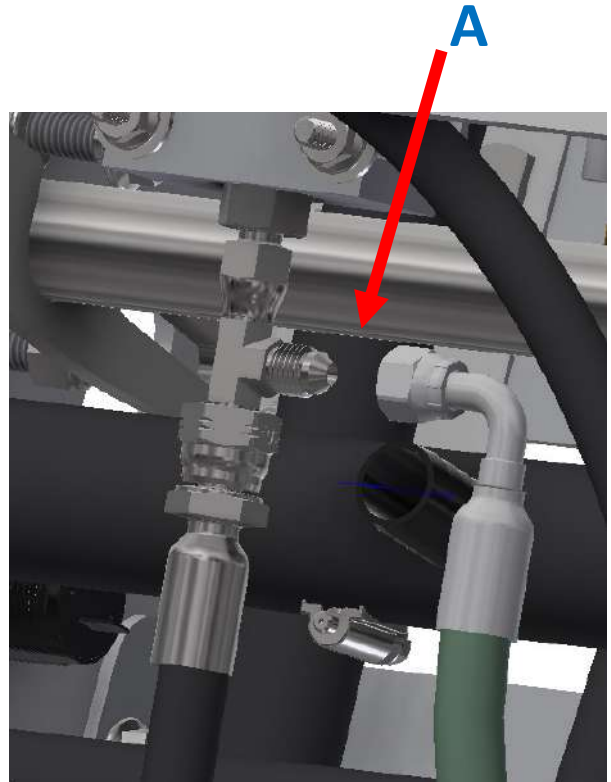

- Attach the other end of the hose to the inlet port on the plow control valve.

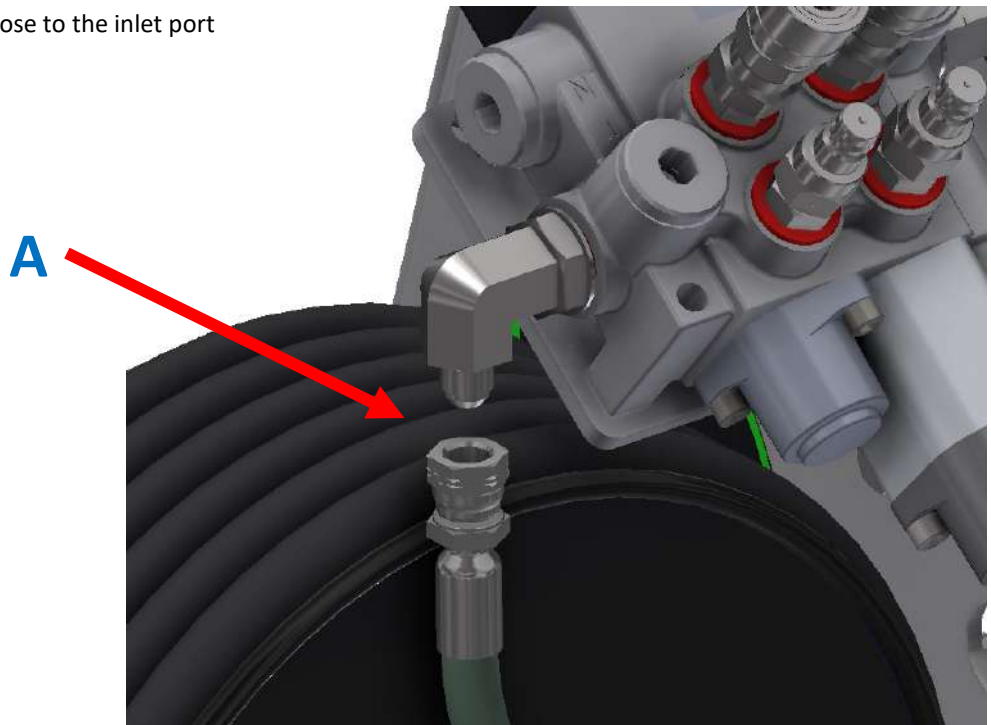

SNOW PLOW KIT INSTRUCTIONS

STEP FIVE: (HSA)

- Using the other 38" hose provided with the kit, attach the straight end to the outlet port on the plow control valve.

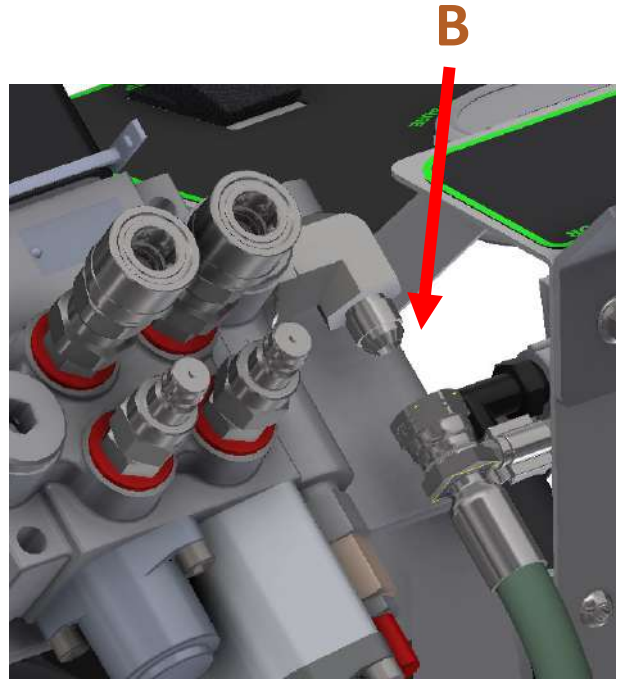

- Attach the other end to inlet port of the hsa valve.

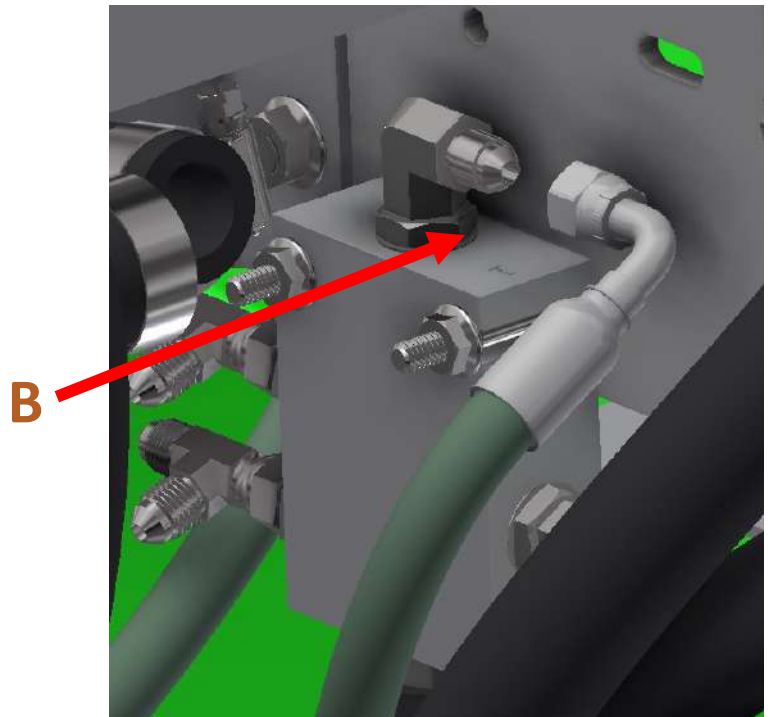

SNOW PLOW KIT INSTRUCTIONS

STEP SIX:

- Attach the snow plow to the hitch using (1) 5/8" X 3" bolt and nut provided with the kit.

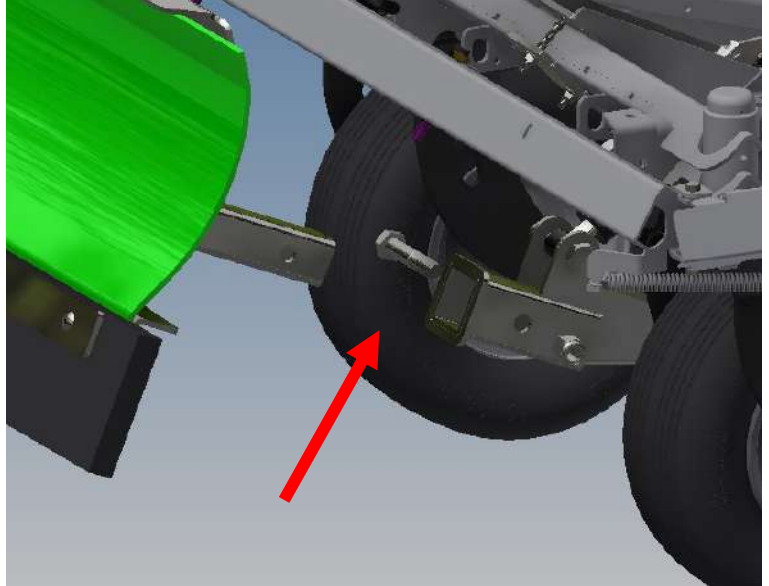

STEP SEVEN:

- Route the snow plow hoses under the lift cylinder, along the right side of the hopper, up over the battery and to the control valve.
- Route the hoses from the plow hitch along the right side of the hopper, up through the opening in the hopper shield, and to the control valve.

NOTE: Zip tie both hose assemblies away from any moving parts to prevent damage.

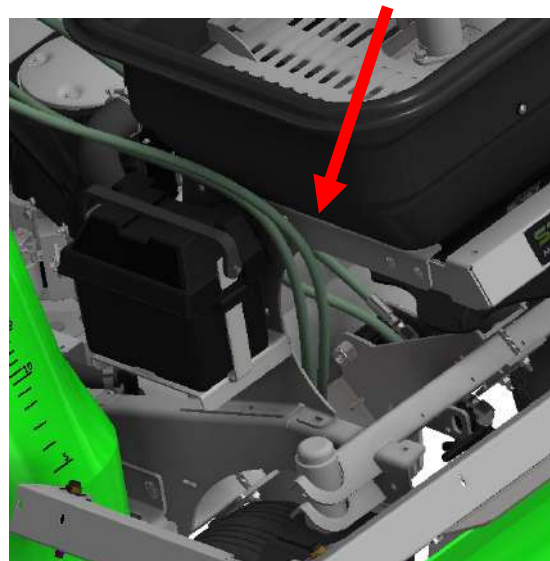
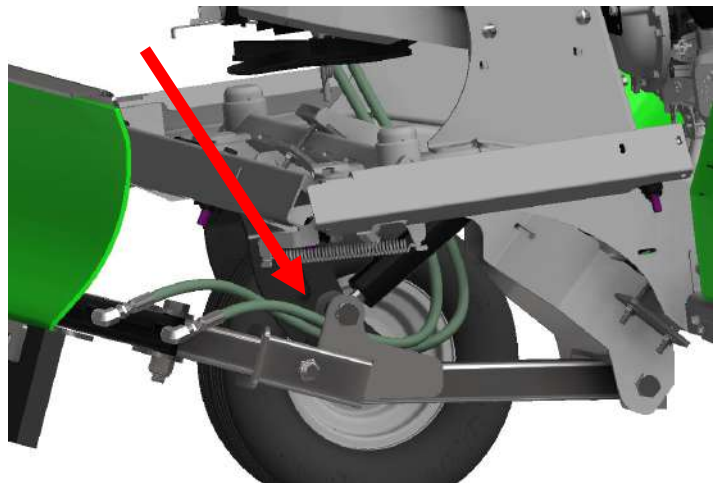

SNOW PLOW KIT INSTRUCTIONS

- Route the hoses from the plow hitch along the right side of the hopper, up through the opening in the hopper shield, and to the control valve.

NOTE: *Zip tie both hose assemblies away from any moving parts to prevent damage.*

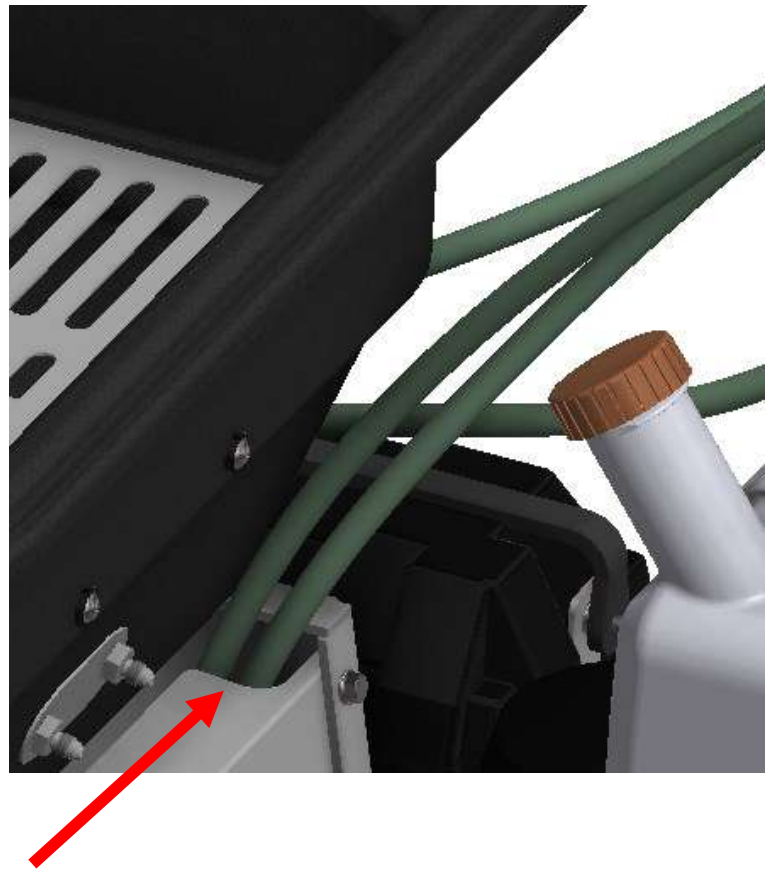
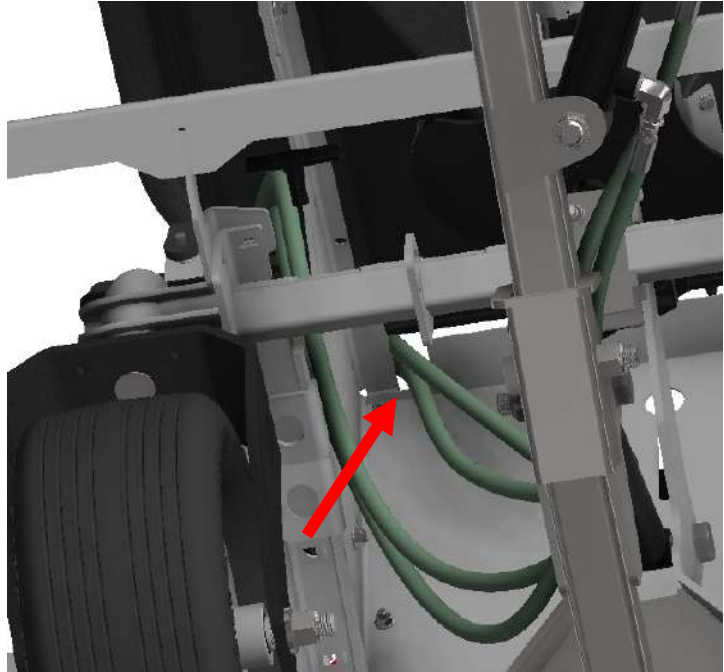

SNOW PLOW KIT INSTRUCTIONS

- Connect the hoses from the snow plow to *left side (ANGLE)* of the control valve.

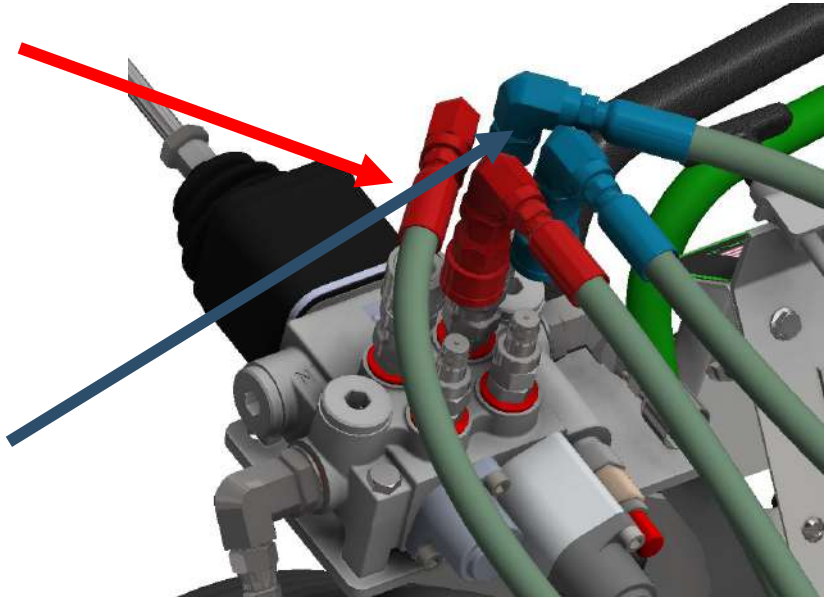

- Connect the hoses from the plow hitch to the *right side (LIFT)* of the control valve.

STEP EIGHT:

- Top off the hydraulic oil tank and start the machine.
- Operate the plow left/right and up/down.

NOTE: *The cylinders and control valve are empty so it will take a few cycles to fill them and get the air out of the system.*

CAUTION!

DO NOT let the machine run out of hydraulic oil

- Top off the oil tank as it gets low, it should take approx. (2) quarts.

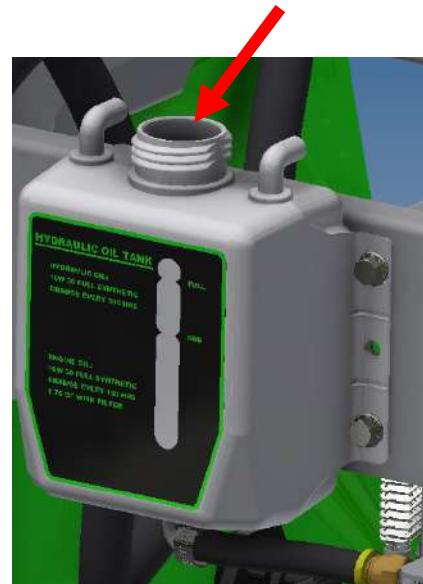

SNOW PLOW KIT INSTRUCTIONS

STEP NINE:

- For SG52 /46 Units, remove the rear tires and install the snow tires provided with the kit.

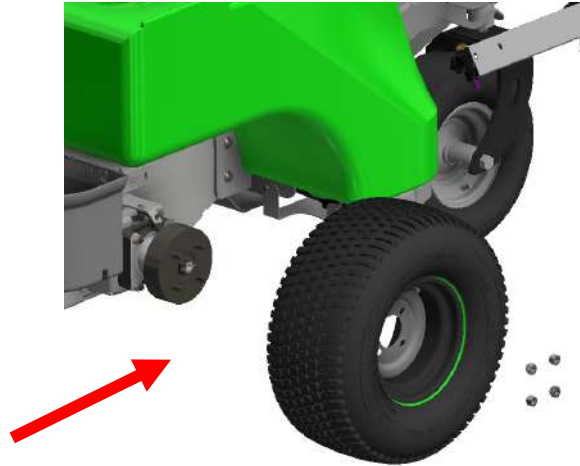

- For SG36 & SG42 Units

- 1 remove the rear tires.
- 2 Install the wheel spacers (T90030).
- 3 Install snow tires.

NOTE: The SG42 dose NOT use wheel spacers.

Both the spacer and snow tires provided with the kit.

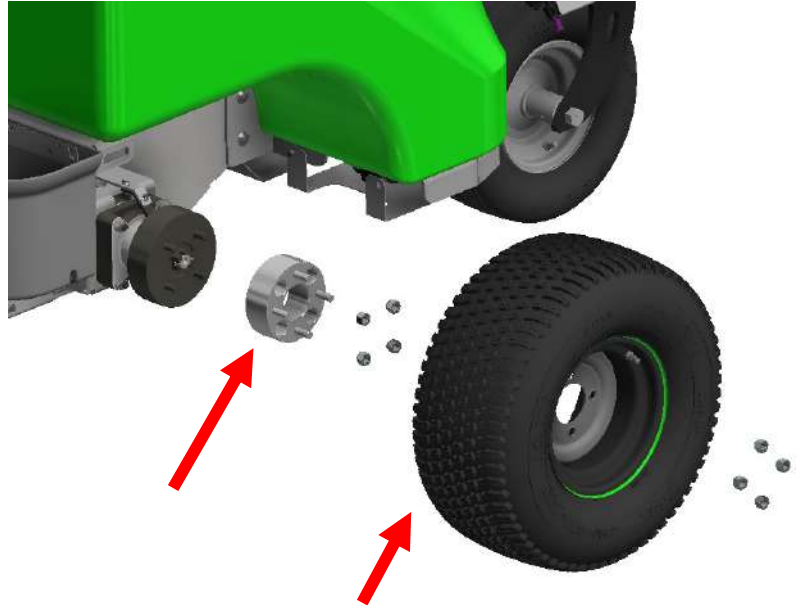

- 4 Remove the front tires and install the 13" front tires provided with the kit.

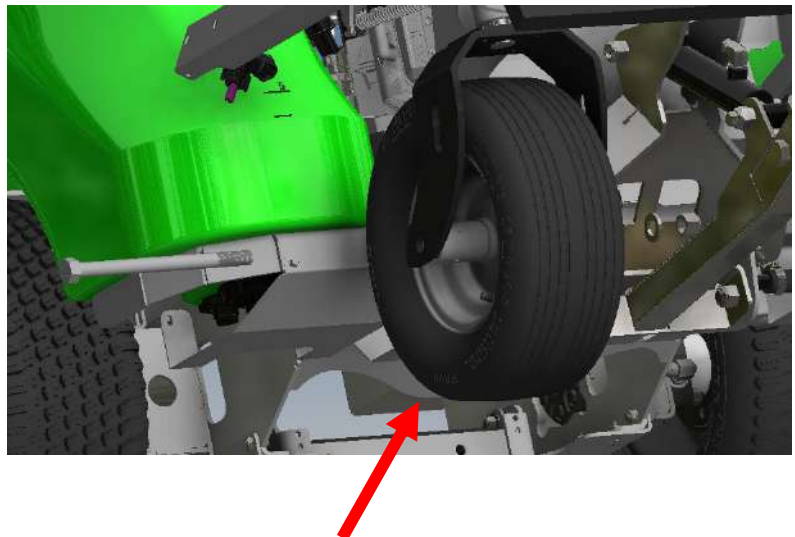



Steel Green Mfg.
 824 S State Road 39
 Lebanon, IN 46052
 (765)-481-2890
www.steelgreenmfg.com

MANUAL PART NO.	MANUAL REV.	DESCRIPTION	KIT PART NO.
SGM-034	D	SG SNOW PLOW ATTACHMENT	SP-36 SP-52