



OPERATOR'S MANUAL



MADE IN THE USA

TABLE OF CONTENTS

GENERAL INFORMATION	3
SPECIFICATIONS	4
SAFE OPERATION	5
CONTROLS AND OPERATION :	
STRIKER SET-UP	6
DASH PANEL	7
MACHINE OPERATION	8
SPRAY PUMP CONTROLS	11
SPRAY BOOM CONTROLS & FOAM MARKER	12
HOSE REEL OPERATION	13
STANDARD VOLUME SPRAY CHART	14
CARE & MAINTENANCE	15
NOTES	18
WARRANTY	21

GENERAL INFORMATION

Thank you for purchasing a Steel Green machine! Please read and understand this manual before operating this piece of equipment. This manual will assist you in areas of operation, safety, and maintenance. Any unresolved question can be directed to Steel Green Mfg. We at Steel Green are excited to hear feedback from our customer base so we can continue to provide you with the most productive and efficient equipment possible.

NOTE: *This manual and all information and illustrations were accurate at the time of publication. Steel Green Mfg. reserves the right to make changes without notice.*

IMPORTANT: READ SAFETY RULES AND INSTRUCTIONS CAREFULLY.

WARNING!

Steel Green units are equipped with an internal combustion engine and should not be used on or near any unimproved forest-covered, brush-covered or grass-covered land unless the engine's exhaust system is equipped with a spark arrester meeting applicable local or state laws (if any). If a spark arrester is used, it should be maintained in effective working order by the operator. In the State of California, the above is required by law (Section 4442 of the California Public Resources Code). Other states may have similar laws. Federal laws apply on federal lands. A spark arrester for the muffler is available through your nearest engine authorized service dealer or contact the service department

Serial Number: _____

Date Purchased: _____

Dealer Name: _____

Dealer Phone Number: _____

SPECIFICATIONS

Dimensions:

MODEL SG54

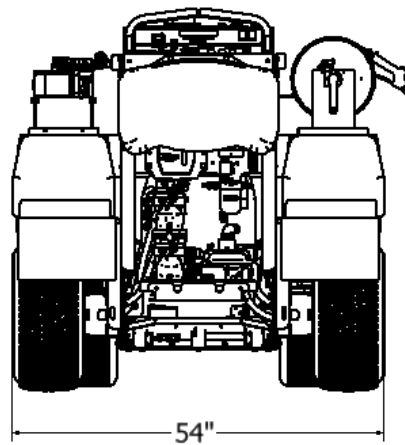
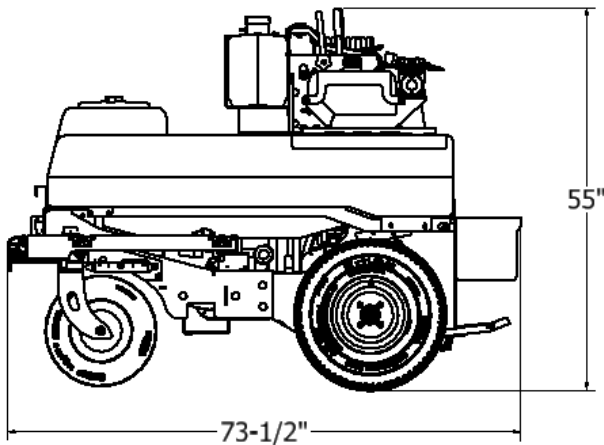
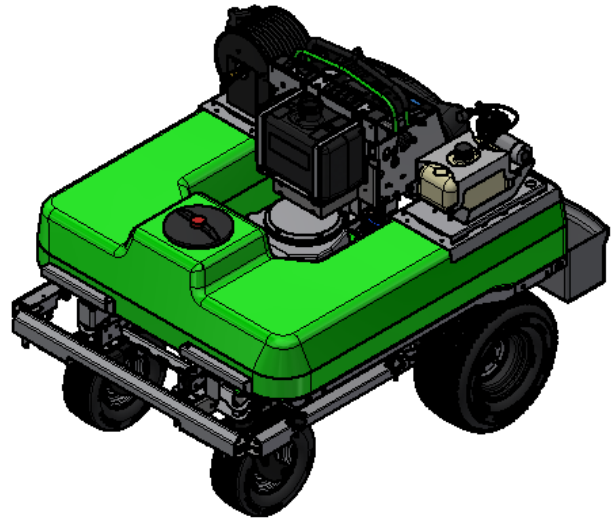
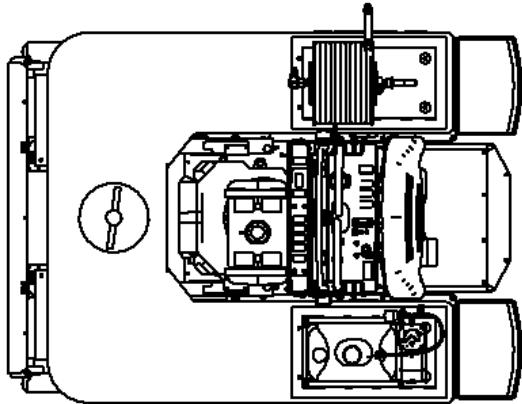

DESCRIPTION	SG54
Weight	970
Front tire	16 x 6.50-8
Rear tire	22 x 11.00-10
Spray Capacity	100 gal.
Spray Width	2', 6', 8', or 10'
Fuel Capacity	5 gal.
Transport Speed	Up to 10 mph
Rate Production	240,000 sq. ft. per fill based on 1/4 gal. spray nozzles

SAFE OPERATION

CAUTION!

THE FOLLOWING IMPORTANT SAFETY INSTRUCTIONS WHICH, IF NOT FOLLOWED, COULD ENDANGER THE PERSONAL SAFETY AND/OR PROPERTY OF YOURSELF AND OTHERS. READ AND FOLLOW ALL INSTRUCTIONS IN THIS MANUAL BEFORE ATTEMPTING TO OPERATE YOUR UNIT. FAILURE TO COMPLY WITH THESE INSTRUCTIONS MAY RESULT IN PERSONAL INJURY.



GENERAL OPERATION

- Do not operate the machine while under the influence of alcohol or drugs.
- Only allow responsible adults, who have practiced driving a zero radius SG unit and are familiar with the instructions to operate the machine. Local restrictions may restrict the age of the operator.

PARKING BRAKE OPERATION

- To engage the parking brake, push the pedal down.

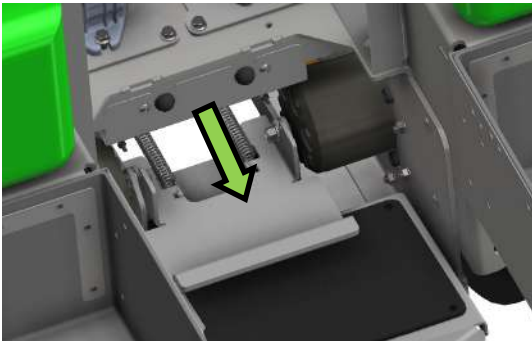

BRAKE ENGAGED

- To release the parking brake, pull the pedal up.

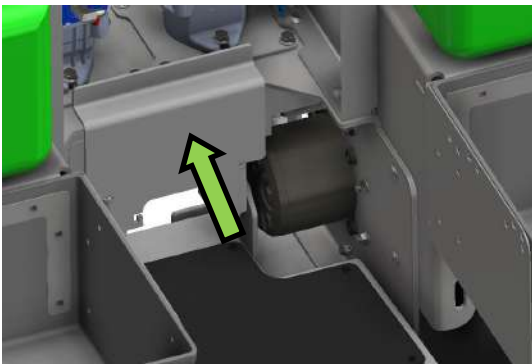

BRAKE DISENGAGED



RE-FUELING

- *ALWAYS STOP THE ENGINE* and allow it to cool before refueling. *NEVER* remove the gas cap to add fuel while the engine is running, and never fill the gas tank on an engine that has been running and is still hot – gas spilled on a hot engine can ignite.
- Never smoke while refueling.
- Do not overfill fuel tank.
- Follow warning label on fuel tank.



SLOPE OPERATION

- Cease operation if stability is questionable, or if you are unsure of the ability to continue safely.
- Keep alert for hidden hazards on the terrain.
- Stay away from drop-offs, ditches and embankments.
- Never operate on slope angles greater than 10° with the SG54 in its basic configuration. The basic configuration is the SG54 no attachments. (A 10° slope is a slope that rises 1 m (3.5 ft) over a horizontal distance of 6.1 m (20 ft.).)

CONTROLS AND OPERATION



Setup Mode

Overview:

Description: Setup mode is crucial for Striker to operate correctly.

SETTINGS ORDER	VALUE	DEFAULT
A. Distance Units	KM/H or M/H	M/H
B. Tire Size	Millimeters	2109mm
C. Clock	12Hr or 24Hr	12Hr
	Time-of-Day	12:00:00
D. Temperature	°F or °C	°F
E. LED Alerts	Temperature High Alert	000°
	Temperature Danger Alert	000°
	Voltage Low Alert	0V
	Voltage Danger Alert	0V
F. Maintenance	Oil Countdown	0000 M/H
	Care Countdown	0000 M/H
G. AVG SPD	Screen 2 or 3	Screen 3
H. Distance	Resolution	Res 2

Enter Setup Mode:

HOLD DOWN ALL THREE
BUTTONS FOR 3 SECONDS.



All segments on the screen will turn black. Release to continue.

Setup Mode

Setup Distance Units:

Striker defaults
to M/H.



TO CYCLE BETWEEN M/H AND KM/H,
PRESS THE LEFT BUTTON.



TO CONFIRM, PRESS THE CENTER BUTTON.
Striker will move on to the next setting.



Setup Wheel Size:

See "Measure Wheel Size" on
page 16 for more information.

SG52, 48, 42 with 22x11x10 tire
Enter 1755

SG36 with 21x7x10 tire enter 1705



MODIFY DIGIT: LEFT BUTTON

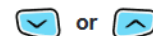

NEXT DIGIT: RIGHT BUTTON

TO CONFIRM, PRESS THE CENTER BUTTON.



Striker will move on to the next setting.

CONTROLS AND OPERATION

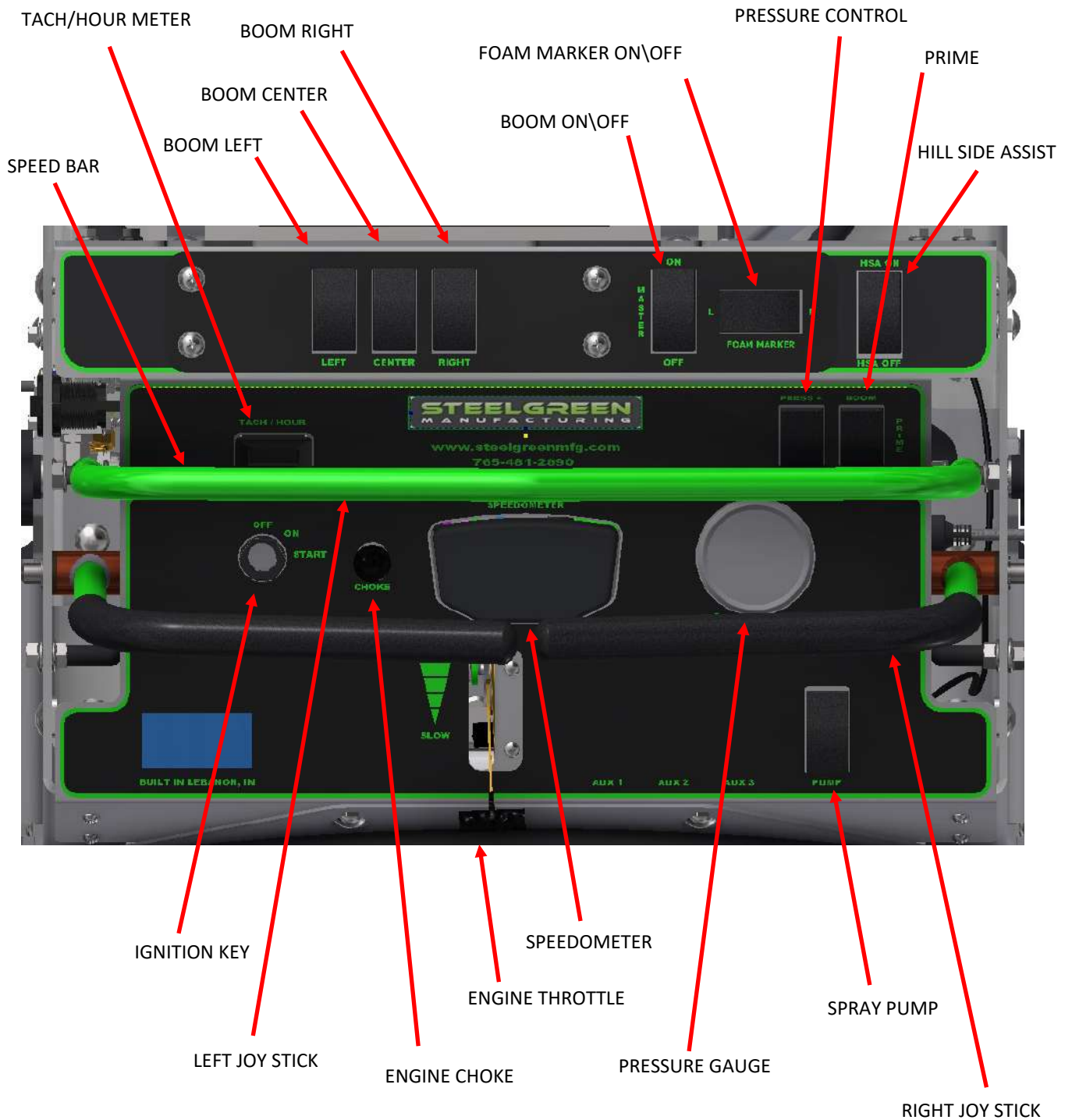

CONTROLS AND OPERATION

MACHINE OPERATION:

- To drive the machine, step up on the foot board and rest against the knee pad.

KNEE PAD

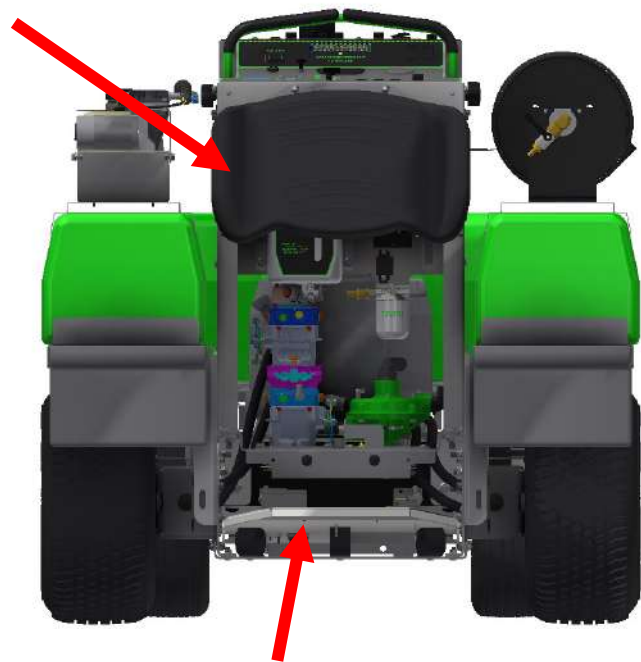

FOOT BOARD

- Start the machine by turning the key with a little throttle and choke open.

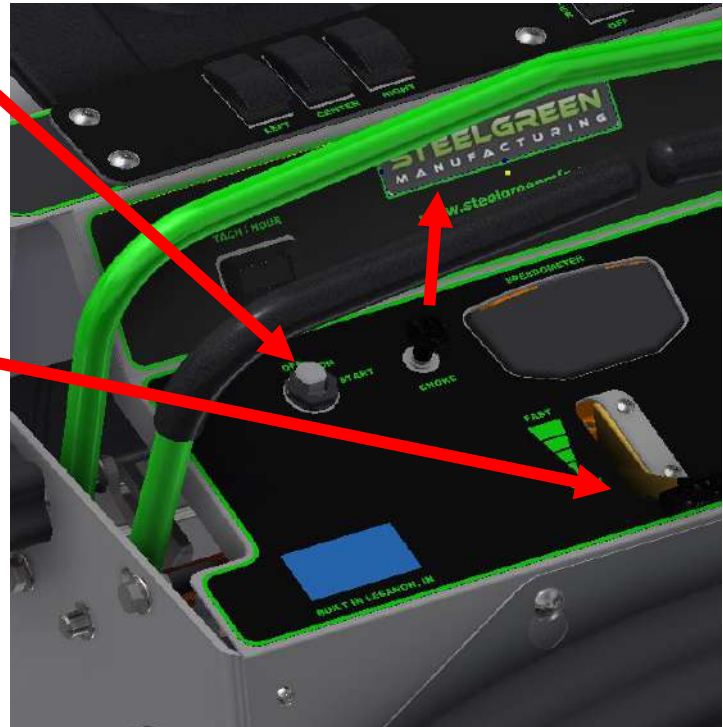

CONTROLS AND OPERATION

JOY STICKS:

- The left joy stick maneuvers the left tire forward and reverse.
- The right joy stick maneuvers the right tire forward and reverse.

DRIVING THE MACHINE:

- Move both joy sticks forward to drive forward.
- Move both joy sticks back to drive in reverse.
- To maneuver a left turn move the right joy stick forward and pull the left one back.
- To maneuver a right turn move the left joy stick forward and pull the right one back.

LEFT TURN



RIGHT TURN



SPEED BAR:

- The speed bar is used to set the maximum speed for spray applications.
- Adjust the speed bar by loosening the black knobs on both sides.
- Move both the joy sticks and speed bar together to set the desired max. speed and tighten the knobs.

SPEED BAR



CONTROLS AND OPERATION

REAR TIRE ADJUSTMENT: The rear tires can be adjusted for balance and more steering.

- Remove the 6 bolts securing the wheel motor assembly to the frame.
- Move the wheel motor assembly to the forward set of holes and reattach it.

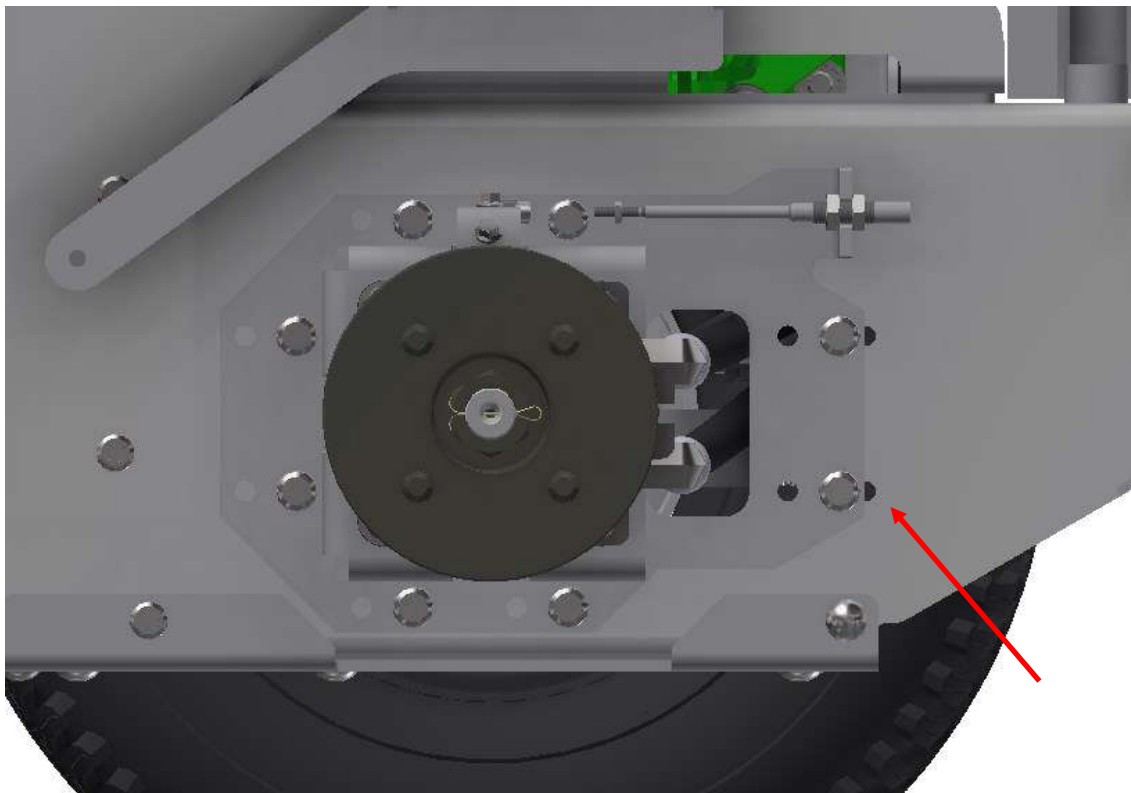

CONTROLS AND OPERATION

SPRAY PUMP CONTROL:

- The spray pump can be turned on/off by one of two ways. A constant rocker switch is located on the dash panel. The pump will constantly run when the switch is pushed in the on position.



NOTE: *If the constant rocker switch is in the "on" position, the momentary switch will not function.*

- A momentary spot spray switch is located on the left side of the operator's foot plate. This switch will only turn the pump on while depressed. Once pressure is lifted from the switch, the pump will shut off.

- Engage the spray pump by pressing the *pump switch* on the dash.



- Set the spray pressure - Increase or decrease the spray pressure by pressing the pressure switch "press +" or "press -"

NOTE: *You can increase or decrease the spray pressure one psi at a time by bumping the switch or press and hold the switch + or - to increase or decrease spray pressure.*

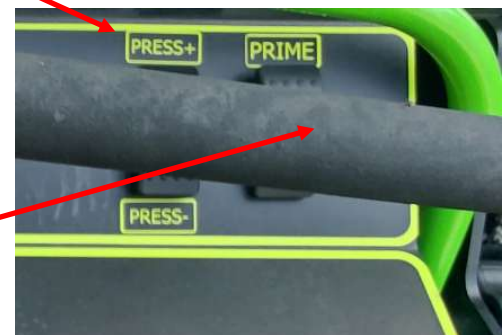

- If the tank is out of liquid press the prime switch to hold the system wide open to prime. Once the prime switch is off it will return to desired spray pressure.

- Spray pressure is measured by the pressure gauge.
- Use the **Spray Calibration Chart** to determine the desired spray pressure.



CONTROLS AND OPERATION

SPRAY BOOM CONTROLS & FOAM MARKER:

The spray boom consists of 3-sections: *Left Wing, Center Section, & Right Wing* (see below).

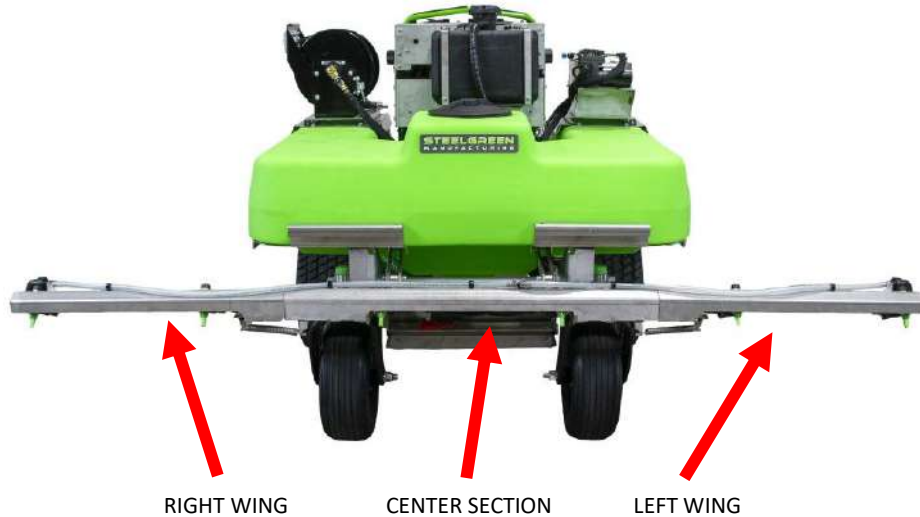

NOTE: Orientation is from the riders view, standing on the machine.



Each section of the boom is controlled by a switch located on the upper dash.

SPRAY BOOM ON & OFF

- Turn all 3 switches on for full spray width, or individually depending on the desired spray width.
The left switch controls the left boom wing.
The center switch controls the center section of the boom.
The right switch controls the right boom wing.
- Each boom wing holds 2 nozzles.
- To power on the foam marker, turn the switch to left or right position.

NOTE: Please refer to the 2.5 gal. foam marker instruction manual for operation.

CONTROLS AND OPERATION

HOSE REEL OPERATION:

- The SG54 is equipped with 100 ft. hose reel.
This is meant to assist with spot spraying and or areas that are not able to be reached by the Machine.
- To operate, turn on pump switch, make sure the spray boom is turned off.
- Use the proper pressure dictated in the *Spray Calibration chart*.
- The Hose Reel or Coil Hose is turned on by a Chrome Valve.
- To apply press the handle together and mimic the spray pattern from the boom.

NOTE: Make sure the Hose Reel or Coil Hose Valve is turned off while not in use. Otherwise back pressure may be created and will cause the nozzle tips to drip.

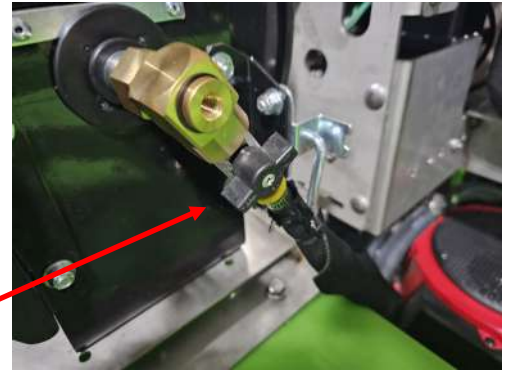

SPRAY CHART

STANDARD VOLUME SPRAY CHART									
NOZZLE	PSI	DROP SIZE	CAPACITY ONE NOZZLE IN GPM	CAPACITY ONE NOZZLE IN OZ/MIN	20"				
					GPA		GALLONS PER 1000 SQ FT		
					4 MPH	5 MPH	3 MPH	4 MPH	5 MPH
AVI-11015 (100)	30	C	0.13	17	9.7	7.7	0.29	0.22	0.18
	40	C	0.15	19	11.1	8.9	0.34	0.26	0.2
	50	C	0.17	22	12.6	10.1	0.39	0.29	0.23
	60	M	0.18	23	13.4	10.7	0.41	0.31	0.24
AVI-11002 (50)	30	VC	0.17	22	12.6	10.1	0.39	0.29	0.23
	40	C	0.2	26	14.9	11.9	0.45	0.34	0.27
	50	C	0.22	28	16.3	13.1	0.5	0.37	0.3
	60	C	0.24	31	17.8	14.3	0.54	0.41	0.33
AVI-1110025 (50)	30	XC	0.22	28	16.3	13.1	0.5	0.37	0.3
	40	VC	0.25	32	18.6	14.9	0.57	0.43	0.34
	50	C	0.28	36	21	16.6	0.63	0.48	0.38
	60	C	0.31	40	23	18.4	0.7	0.53	0.42
AVI-11003 (50)	30	XC	0.26	33	19.3	15.4	0.59	0.44	0.35
	40	VC	0.3	38	22	17.8	0.68	0.51	0.41
	50	C	0.34	44	25	20	0.77	0.58	0.46
AVI-11004 (50)	30	XC	0.35	45	26	21	0.79	0.6	0.48
	40	XC	0.4	51	30	24	0.91	0.68	0.54
	50	VC	0.45	58	33	27	1	0.77	0.61
AVI-11005 (50)	30	XC	0.43	55	32	26	0.97	0.73	0.58
	40	XC	0.5	64	37	30	1.1	0.85	0.68
	50	VC	0.56	72	62	33	1.3	0.95	0.76
AVI-11006 (50)	30	XC	0.52	67	39	31	1.2	0.68	0.71
	40	XC	0.66	77	45	36	1.4	1	0.82
	50	VC	0.67	86	50	40	1.5	1.1	0.91
HIGH VOLUME SPRAY CHART (XRC TIPS)									
XRC11010	15	VC	0.61	78	45	36	1.4	1	0.83
	20	C	0.71	91	53	42	1.6	1.2	0.97
	30	C	0.87	111	65	52	2	1.5	1.2
	40	M	1	128	74	59	2.3	1.7	1.4
XRC11015	15	VC	0.92	118	68	55	2.1	1.6	1.3
	20	VC	1.06	136	79	63	2.4	1.8	1.4
	30	VC	1.3	166	97	77	2.9	2.2	1.8
	40	C	1.5	192	111	89	3.4	2.6	2
XRC11020	15	XC	1.22	156	91		2.8	2.1	
	20	XC	1.41	180	105		3.2	2.4	
	30	VC	1.73	221	128		3.9	2.9	
	40	VC	2	256	149		4.5	3.4	

$$\text{GPM (per nozzle)} = \frac{\text{GPA} \times \text{MPH} \times \text{W}}{5,940}$$

$$\frac{1}{\text{min (per nozzle)}} = \frac{1/\text{ha} \times \text{km/hr} \times \text{W}}{60,000}$$

$$\text{GPM (per nozzle)} = \frac{\text{GAL}/1000\text{FT}^2 \times \text{MPH} \times \text{W}}{136}$$

$$\text{GAL}/1000\text{FT}^2 = \frac{136 \times \text{GPM (per nozzle)}}{\text{MPH} \times \text{W}}$$

$$\text{GPA} = \frac{5,940 \times \text{GPM (per nozzle)}}{\text{MPH} \times \text{W}}$$

$$\frac{1}{\text{min}} = \frac{60,000 \times 1/\text{min (per nozzle)}}{\text{km/hr} \times \text{W}}$$

GPM = Gallons per minute

GPA = Gallons per acre

GAL/1000FT² = Gallons per 1000 square feet

MPH = Miles per hour

W = Nozzle spacing (in or cm) for broadcast spraying

CARE & MAINTENANCE

WARNING!

- *Do not operate the engine in a confined space where carbon monoxide and other fumes can accumulate.*
- *Never lubricate, service, or adjust the machine or spreader while it is moving or running.*
- *Keep hands, feet, clothing, hair, and loose items away from any moving parts.*

CAUTION!

- *Understand service and maintenance procedure before performing any work on this machine or spreader.*
- *Disconnect the battery before making any repairs.*
- *Keep all parts in good condition & operating properly.*
- *Fix damages immediately. Replace all worn or damaged parts.*
- *Check all hardware at frequent intervals to ensure they are tight.*

MAINTENANCE TIPS

- *Always avoid letting product sit in the tanks and pump for an extended period of time.*
- *Blowing off unit is preferred over washing. But if washing unit dry it off as best as possible.*
- *Refer to engine owner's manual for all other specs.*

WINTERIZATION

- Proper winterization of the spray system helps to prevent damage to the system due to wintertime freezing. Follow these easy steps:

- 1 Drain all of the remaining liquid from the tanks and spray system.
- 2 Fill the tanks with enough RV antifreeze to fill the entire system.
- 3 Turn on the liquid pump and open all boom valves until solution is visible out of spray nozzles. Close boom valves.
- 4 Open valve for hose reel and begin spraying solution thru the nozzle.
- 5 Put the recommended amount of fuel stabilizer and (follow label for instructions).

CARE & MAINTENANCE

SUGGESTED SERVICE	ACTION	DAILY	WEEKLY	BI-WEEKLY	MONTHLY	YEARLY	HOURS
Front Caster Wheels	Grease				X		
Front Caster Yoke	Grease				X		
Front Tire Pressure	22PSI		X				
Front Tire Bearing	Preload				X		
Rear Tire Pressure	18PSI		X				
Rear Lug Nut	Torque 75Lbs				X		
Rear Hub Castle Nut	Check the cotter pin				X		
Frame Hardware	Check all bolts & fasteners				X		
Idler Pulley Arm	Grease				X		
Belt Wear	Cracks, Tears, Missing Material				X		
Engine Oil	Check	X					
	Change						
Engine Air Filter	Check/Change if needed		X			Replace	100 Hrs.
Engine Air Pre-Filter							
Engine Fuel Filter						Replace	
Engine Spark Plugs							
Hydraulic Oil	Change						500 Hrs.
Hydraulic Oil Filter							
Hydraulic Oil Level	Check	X					
Hydro System Fittings	Check for leaks		X				
Chemical Leaks	Check	X					
Spray Nozzle Tips							
Spray Nozzle Tip Screens							
Spray Gun Tip							
Spray Nozzle Gasket			X				
Spray System Hoses			X				
In-Line Filter				X			
Spray Gun Hose Reel\Coil Hose				X			

The suggested maintenance schedule above is recommended for normal use, maintenance will vary for heavier use. Steel Green Mfg. reserves the right to determine usage.

CARE & MAINTENANCE

GREASE POINTS

There are 5 grease points on a SG machine:

- 1 on each front tire.
- 1 on each of the caster tubes.
- 1 on the idler arm.

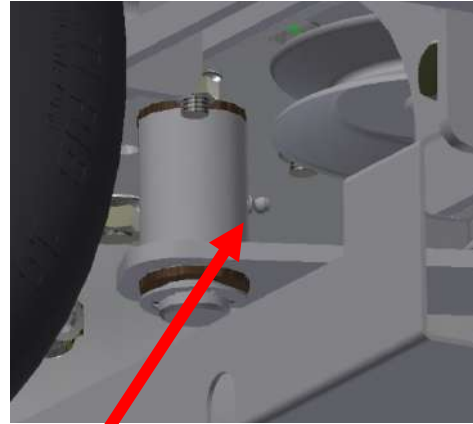

Idler Arm grease point

Caster Tube Grease Point
(BOTH SIDES)

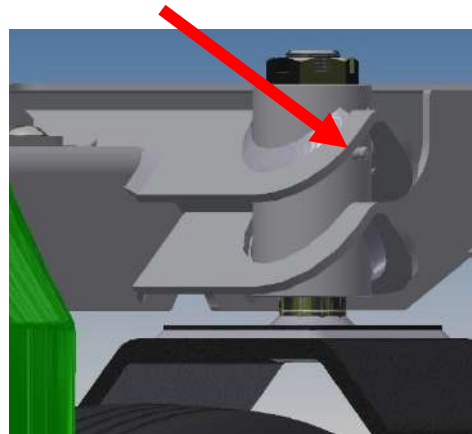

Tire Grease point
(BOTH FRONT TIRES)

NOTES

NOTES

NOTES

Steel Green Manufacturing, LLC

1-Year Limited Warranty

A. WHAT IS COVERED – This Warranty applies to equipment having model numbers SG54, SG52, SG46, SG42, and SG36 (“Equipment”) manufactured by Steel Green Manufacturing, LLC, an Indiana limited liability company (“Steel Green”). This Warranty only applies to Equipment purchased directly from Steel Green or an authorized dealer or distributor of the Equipment (“Authorized Dealers”) in the United States. Except for Excluded Parts (as hereinafter defined), Steel Green agrees to repair or replace, at its option, any original component of the Equipment that is defective in material or workmanship (collectively “Warranty Service”). This Warranty begins on the date the product is delivered to the original purchaser and continues for a period of twelve (12) months thereafter (the “Warranty Term”).

B. WHAT IS NOT COVERED – This Warranty does not apply to the following categories of equipment: (1) used Equipment, unless there has been an Approved Transfer (as hereinafter defined); or (2) Equipment that has been altered or modified in ways not approved by Steel Green, including, but not limited to, setting injection pump fuel delivery above specifications stated in the owner’s manual. Furthermore, this Warranty does not apply to damage due to any of the following: (1) normal wear and tear; (2) the failure to perform reasonable and proper maintenance; (3) the failure to follow instructions and recommendations in the owner’s manual; (4) negligent or intentional misuse; (5) failure to properly store the Equipment; (6) vandalism; (7) the elements and inclement weather; or (8) collision or accident. “Excluded Parts” means the following parts, which are not covered by and are expressly excluded from this Warranty: (1) consumable parts, such as oil, filters, belts, brakes, and spark plugs; (2) tires; (3) batteries; and (4) the engine. The manufacturers of the Excluded Parts may provide a separate warranty. See manufacturers’ manuals for details.

C. WHO IS COVERED – This Warranty extends to the original purchaser of the Equipment who completes and returns the warranty registration card included with the Equipment to Steel Green and to any subsequent owner (collectively “you”), provided the subsequent owner notifies Steel Green of the change in ownership and Steel Green approves the transfer of this Warranty (“Approved Transfer”). An Approved Transfer does not extend the Warranty Term.

D. HOW IS WARRANTY SERVICE OBTAINED – To obtain Warranty Service, you must: (1) report the Equipment defect to Steel Green within the Warranty Term; and (2) deliver the Equipment for Warranty Service within a reasonable time thereafter. All Warranty Service must use new or remanufactured parts or components furnished or approved by Steel Green and must be performed by Steel Green, an Authorized Dealer, or a service center approved by Steel Green (“Authorized Service Center”), as directed by Steel Green. This Warranty only covers the costs of parts and labor associated with Warranty Service. You are responsible for delivering the Equipment for Warranty Service, at your sole cost and expense. Steel Green is not responsible for any costs or liability associated with any pickup, delivery, or other transportation required to obtain Warranty Service.

E. ADDITIONAL LIMITATIONS AND EXCLUSIONS – Except as expressly provided herein, Steel Green makes no warranties, representations, conditions or promises, express or implied, as to the quality, performance or freedom from defect of the Equipment covered by this Warranty. STEEL GREEN DOES NOT MAKE ANY STATUTORY OR IMPLIED WARRANTIES OR CONDITIONS OF MERCHANTABILITY OR FITNESS FOR A PARTICULAR PURPOSE, AND SUCH WARRANTIES ARE EXPRESSLY DISCLAIMED. TO THE EXTENT THEY ARE LEGALLY REQUIRED, ANY IMPLIED WARRANTIES OR CONDITIONS SHALL BE LIMITED IN DURATION TO THE WARRANTY TERM.

STEEL GREEN'S ONLY LIABILITY WITH RESPECT TO THIS WARRANTY AND YOUR EXCLUSIVE REMEDY SHALL BE FOR THE REPAIR OR REPLACEMENT OF PARTS AS SET FORTH HEREIN. NO CLAIM FOR BREACH OF WARRANTY SHALL ENTITLE YOU TO CANCELLATION OR RESCISSION OF THE PURCHASE OF THE EQUIPMENT.

IN NO EVENT WILL ANY AUTHORIZED DEALER, ANY AUTHORIZED SERVICE CENTER, STEEL GREEN OR ANY COMPANY AFFILIATED WITH STEEL GREEN BE LIABLE FOR INCIDENTAL OR CONSEQUENTIAL DAMAGES. Examples of such damages include, but are not limited to: (1) the loss or damage to person or property other than that covered by this Warranty; (2) attorneys' fees; (3) claims for lost revenue or lost profits; and (4) rental costs of similar equipment to the Equipment.

SOME STATES DO NOT ALLOW THE EXCLUSION OR LIMITATION OF INCIDENTAL OR CONSEQUENTIAL DAMAGES, OR LIMITATIONS ON THE DURATION OF AN IMPLIED WARRANTY, SO THE ABOVE LIMITATIONS AND EXCLUSIONS MAY NOT APPLY TO YOU. THIS WARRANTY GIVES YOU SPECIFIC LEGAL RIGHTS, BUT YOU MAY ALSO HAVE OTHER RIGHTS, WHICH VARY FROM STATE TO STATE.

F. NO OTHER WARRANTIES – NO OTHER PERSON OR ENTITY, INCLUDING ANY AUTHORIZED DEALER, HAS AUTHORITY TO MAKE ANY WARRANTY, REPRESENTATION, CONDITION OR PROMISE ON BEHALF OF STEEL GREEN, OR TO MODIFY THE TERMS OR LIMITATIONS OF THIS WARRANTY IN ANY WAY, WHETHER ORALLY OR IN WRITING. STEEL GREEN MAKES NO OTHER WARRANTY RELATED TO THE EQUIPMENT OR ANY OTHER ITEM UNLESS IT DELIVERS TO YOU A SEPARATE WRITTEN WARRANTY.

G. CONTACT – To obtain a replacement warranty registration card or report a defect in any Equipment, to find the nearest Authorized Dealer or Authorized Service Center or report your dissatisfaction with their assistance, or to otherwise obtain information regarding this Warranty, please contact Steel Green.

Steel Green Manufacturing LLC
Attn: Customer Service
824 S State Road 39
Lebanon, Indiana 46025
(765) 481-2890
sales@steelgreenmfg.com
Steelgreenmfg.com



WARRANTY REGISTRATION FORM

Fill out form completely and return to **Steel Green Manufacturing**
Email: sales@steelgreenmfg.com
Mail: 824 S State Road 39, Lebanon, IN 46052

CONTACT INFORMATION

Company Name: _____

Contact Name: _____

Street: _____

City: _____ State: _____ ZIP Code: _____

Phone: _____ Email: _____

MACHINE INFORMATION

Serial Number: _____ Date of Purchase: _____

Dealer Name: _____

Street: _____

City: _____ State: _____ ZIP Code: _____

Phone: _____ Salesperson: _____



steelgreenmfg.com (765) 481-2890    @SteelGreenMFG

OPERATORS MANUAL		
PART NO.	REV.	DESCRIPTION
SGOM-004	B	OPERATORS MANUAL, SG54 SERIES



PRINTED IN U.S.A.