

STEELGREENTM

M A N U F A C T U R I N G

INSTRUCTION MANUAL

HYDRAULIC OIL CHANGE

Models: SG36, SG42, SG46, & SG52



HYDRAULIC OIL CHANGE INSTRUCTIONS

NOTICE

Change hydraulic oil & filter every 500 hours with 5w50 full synthetic oil. API service classification SN plus, Resource conserving; ILSAC GF-5.

STEP 1: Remove the knee pad to access the hydraulic oil reservoir.

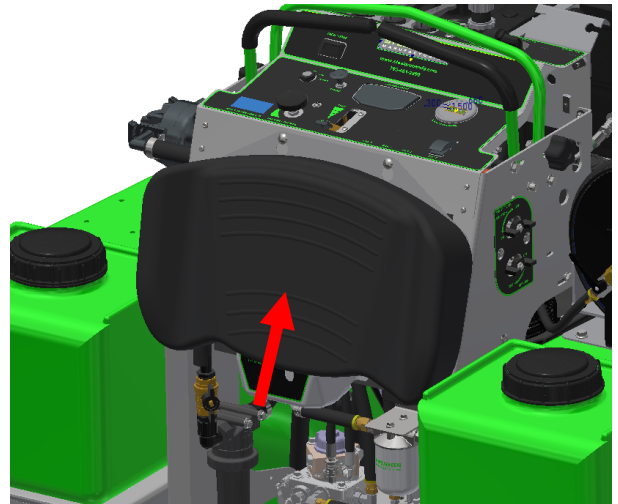

STEP 2:

- Loosen and remove the cap from the hydraulic oil reservoir.
- Disconnect the rear hoses from the hydraulic pumps, place the hoses over a proper container draining the hydraulic oil.
- Once the oil has been drained, reconnect the hoses to the pumps.

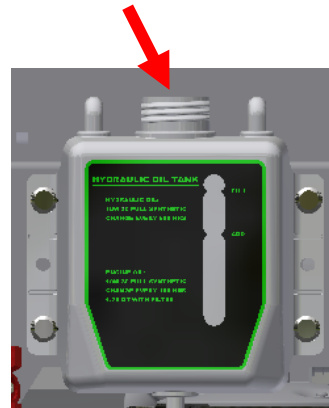

NOTICE

To drain the most oil out as possible, you can also remove the rear tires and disconnect the hoses from the wheel motors to drain the oil at the lowest point.

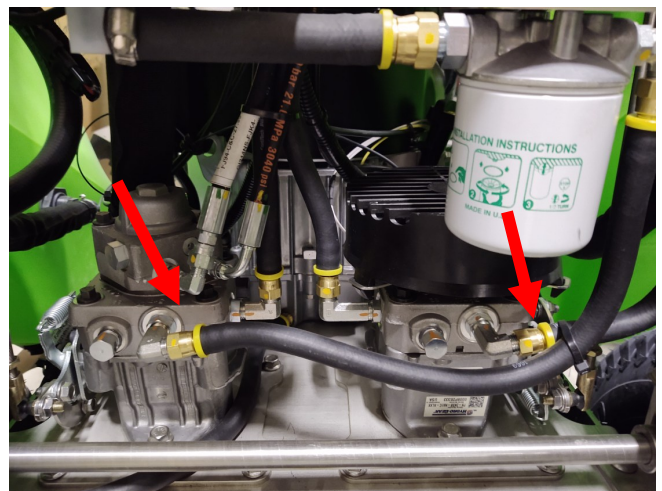
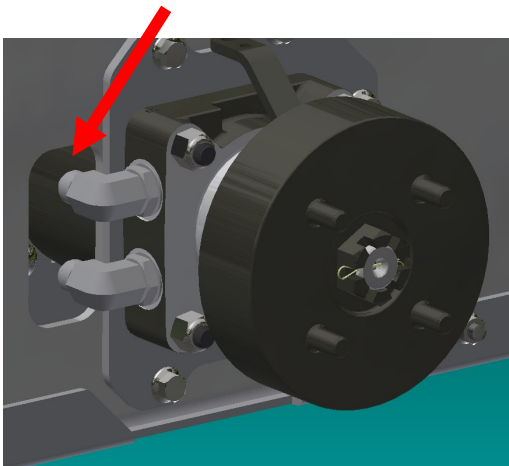

HYDRAULIC OIL CHANGE INSTRUCTIONS

STEP 3: Remove and replace the hydraulic oil filter.

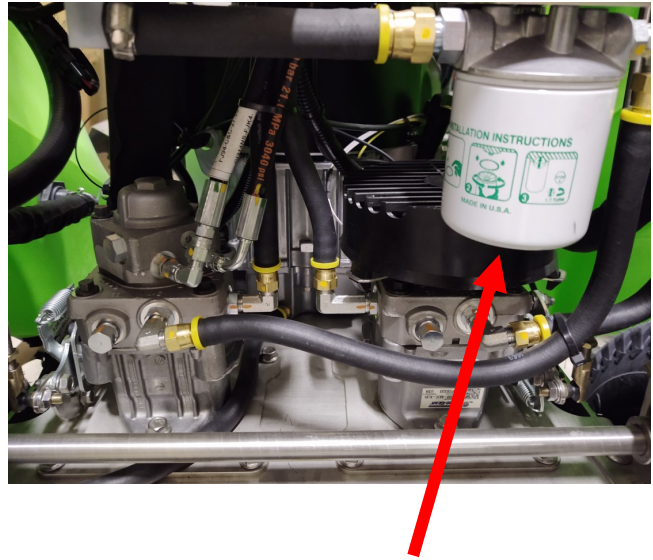

STEP 4:

- Refill the hydraulic oil to the full line. with 5w50 full synthetic oil.
- Jack up the rear of the machine so the rear tires are off of the ground.
- Start and run the machine in forward and reverse to cycle the hydraulic oil back through the system, *you will see the oil level drop in the reservoir.*
- Once the oil level has dropped, refill the reservoir to the full line and reinstall the cap.

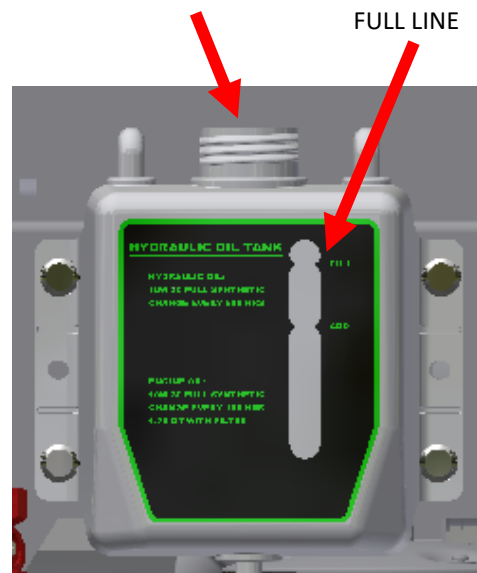



Steel Green Mfg.
824 S State Road 39
Lebanon, IN 46052
(765)-481-2890
www.steelgreenmfg.com

MANUAL PART NO.	MANUAL REV.	DESCRIPTION
SGM-027	C	SG HYDRAULIC OIL CHANGE