

# STEELGREEN MANUFACTURING™



**SGXL**

## ZERO-TURN SPREADER\SPRAYER OPERATOR & SERVICE MANUAL

For additional information, please visit us at [www.steelgreenmfg.com](http://www.steelgreenmfg.com)



**MADE IN THE USA**



# TABLE OF CONTENTS

GENERAL INFORMATION .....	3
SPECIFICATIONS .....	4
SAFE OPERATION .....	6
CONTROLS AND OPERATION .....	7
STRIKER SET-UP .....	7
CONTROL PANEL .....	8
OPERATION .....	9
SPRAY SYSTEM .....	11
STANDARD VOLUME SPRAY CHART .....	14
HOPPER ATTACHMENT .....	15
HOPPER OPERATION .....	22
SPREADER CALIBRATION / RATE CHARTS .....	25
SPREADER AND HOPPER CLEANING .....	25
HOPPER DRAIN INSTRUCTIONS .....	26
CARE & MAINTENANCE .....	27
NOTES .....	35
WARRANTY .....	37



# GENERAL INFORMATION

Thank you for purchasing a Steel Green machine! Please read and understand this manual before operating this piece of equipment. This manual will assist you in areas of operation, safety, and maintenance. Any unresolved question can be directed to Steel Green Mfg. We at Steel Green are excited to hear feedback from our customer base so we can continue to provide you with the most productive and efficient equipment possible.

## NOTICE

*This manual and all information and illustrations were accurate at the time of publication. Steel Green Mfg. reserves the right to make changes without notice.*

**IMPORTANT: READ SAFETY RULES AND INSTRUCTIONS CAREFULLY.**

## WARNING

*Steel Green units are equipped with an internal combustion engine and should not be used on or near any unimproved forest-covered, brush-covered or grass-covered land unless the engine's exhaust system is equipped with a spark arrester meeting applicable local or state laws (if any). If a spark arrester is used, it should be maintained in effective working order by the operator. In the State of California, the above is required by law (Section 4442 of the California Public Resources Code). Other states may have similar laws. Federal laws apply on federal lands. A spark arrester for the muffler is available through your nearest engine authorized service dealer or contact the service department .*

Serial Number: \_\_\_\_\_

Date Purchased: \_\_\_\_\_

Dealer Name: \_\_\_\_\_

Dealer Phone Number: \_\_\_\_\_



SPECIFICATIONS

DIMENSIONS:

SGXL SPRAY SYSTEM

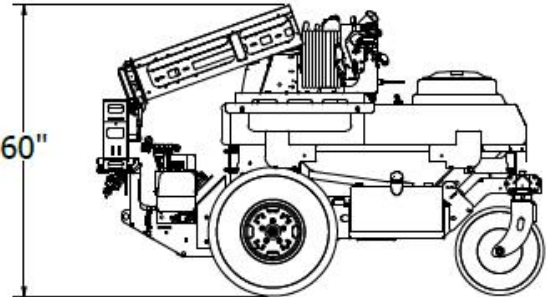
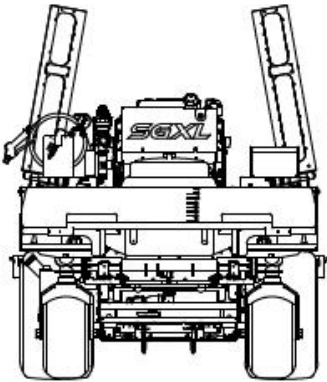
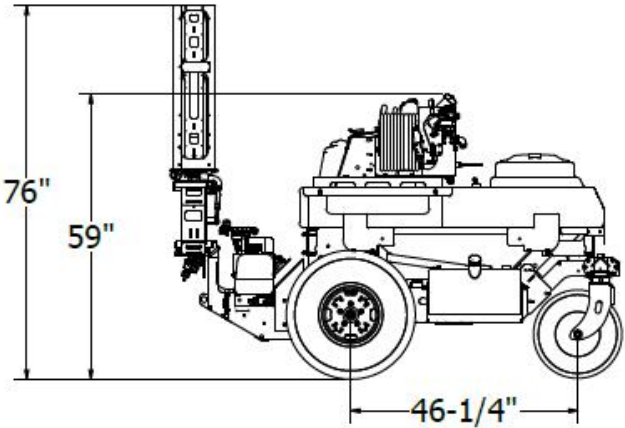
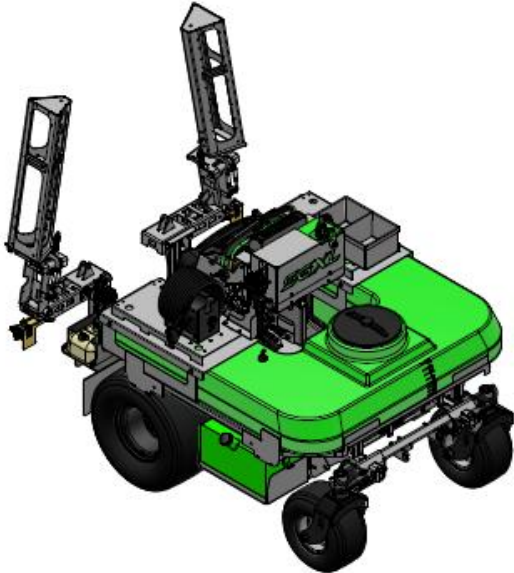
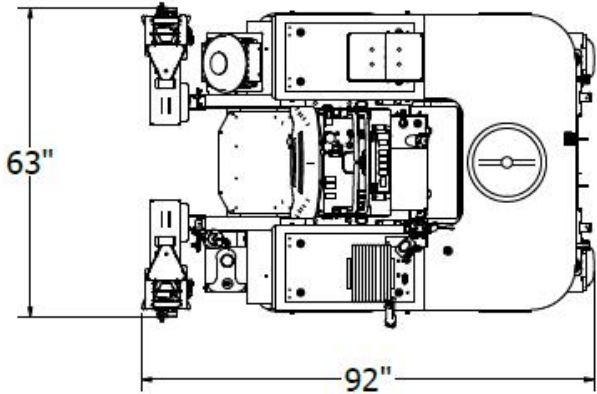



# SPECIFICATIONS

## SGXL ALL GRANULAR SYSTEM

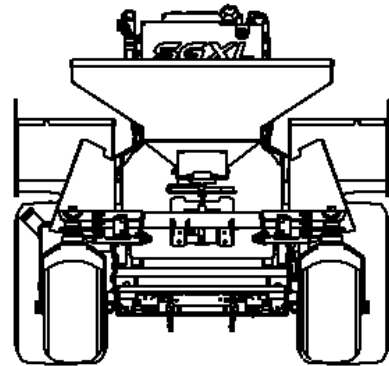
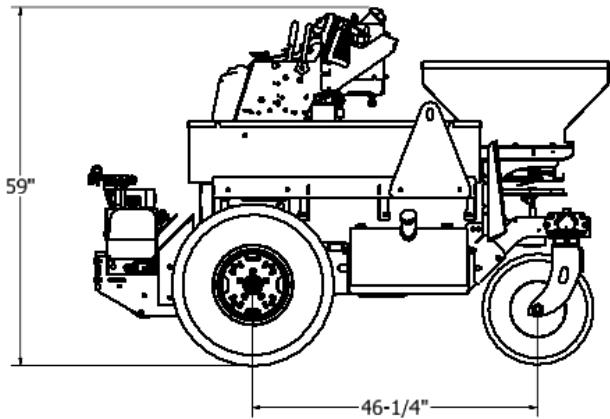
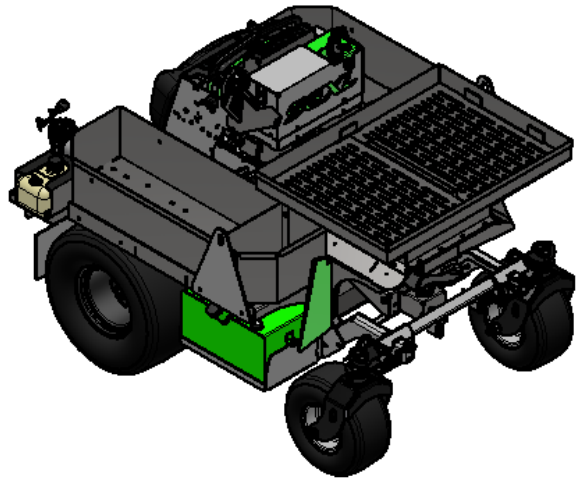
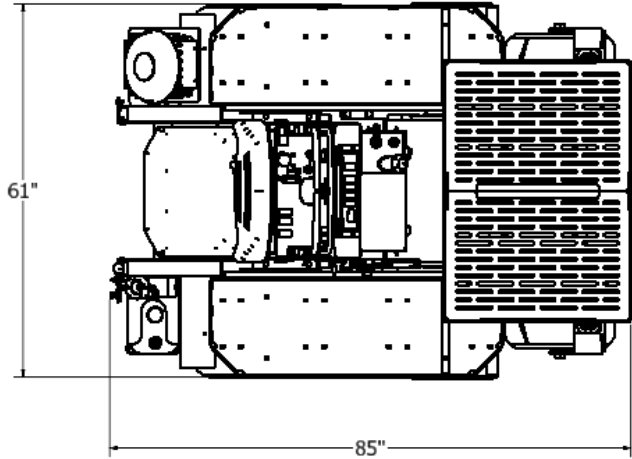

DESCRIPTION	SGXL SPRAY SYSTEM	SGXL ALL GRANULAR SYSTEM
Weight	1750	1580
Front Tire	18 X 9.5 X 8	
Rear Tire	26 X 14 X 12	
Spray Capacity	120 gal.	N/A
Spray Width	15'	N/A
Hopper Capacity	N/A	350 lbs.
Variable Spread Width	N/A	Up to 25'
Fuel Capacity	8 gal.	
Transport Speed	Up to 12 mph	
Rate Production	120,000 sq. ft. per fill based on 1 gal. spray nozzles	N/A



## SAFE OPERATION

### CAUTION

*THE FOLLOWING IMPORTANT SAFETY INSTRUCTIONS WHICH, IF NOT FOLLOWED, COULD ENDANGER THE PERSONAL SAFETY AND/OR PROPERTY OF YOURSELF AND OTHERS. READ AND FOLLOW ALL INSTRUCTIONS IN THIS MANUAL BEFORE ATTEMPTING TO OPERATE YOUR UNIT. FAILURE TO COMPLY WITH THESE INSTRUCTIONS MAY RESULT IN PERSONAL INJURY.*

#### GENERAL OPERATION:

- Do not operate the machine while under the influence of alcohol or drugs.
- Only allow responsible adults, who have practiced driving a zero radius SG unit and are familiar with the instructions to operate the machine. Local restrictions may restrict the age of the operator.

#### RE-FUELING:

- *ALWAYS STOP THE ENGINE* and allow it to cool before refueling. *NEVER* remove the gas cap to add fuel while the engine is running, and never fill the gas tank on an engine that has been running and is still hot – gas spilled on a hot engine can ignite.
- Never smoke while refueling.
- Do not overfill fuel tank.
- Follow warning label on fuel tank.

#### SLOPE OPERATION:

- Cease operation if stability is questionable, or if you are unsure of the ability to continue safely.
- Keep alert for hidden hazards on the terrain.
- Stay away from drop-offs, ditches and embankments.
- Never operate on slope angles greater than 13° with the SGXL in its basic configuration. The basic configuration is defined as an SGXL and no attachments. (A 13° slope is a slope that rises 1.4 m (4.6 ft) over a horizontal distance of 6.1 m (20 ft).)
- When using attachments, never operate the SGXL on slope angles greater than 10°. The addition of an extra tank, or other attachments will increase the risk of a rollover. (A 10° slope is a slope that rises 1 m (3.5 ft) over a horizontal distance of 6.1 m (20 ft).)



# CONTROLS AND OPERATION

## SPEED / VOLTAGE STRIKER



### Setup Mode

#### Overview:

Description: Setup mode is crucial for Striker to operate correctly.

SETTINGS ORDER	VALUE	DEFAULT
A. Distance Units	KM/H or M/H	M/H
B. Tire Size	Millimeters	2109mm
C. Clock	12Hr or 24Hr Time-of-Day	12Hr 12:00:00
D. Temperature	°F or °C	°F
E. LED Alerts	Temperature High Alert	000°
	Temperature Danger Alert	000°
	Voltage Low Alert	0V
	Voltage Danger Alert	0V
F. Maintenance	Oil Countdown	0000 M/H
	Care Countdown	0000 M/H
G. AVG SPD	Screen 2 or 3	Screen 3
H. Distance	Resolution	Res 2

#### Enter Setup Mode:

HOLD DOWN ALL THREE  
BUTTONS FOR 3 SECONDS.



All segments on the screen will turn black. Release to continue.

### Setup Mode

#### Setup Distance Units:

Striker defaults  
to M/H.



TO CYCLE BETWEEN M/H AND KM/H,  
PRESS THE LEFT BUTTON.



TO CONFIRM, PRESS THE CENTER BUTTON.  
Striker will move on to the next setting.



#### Setup Wheel Size:

See "Measure Wheel Size" on  
page 5 for more information.

SGXL tire size = 26.5 X 14.00 - 12

Enter - 1987



MODIFY DIGIT: LEFT BUTTON



or



NEXT DIGIT: RIGHT BUTTON

TO CONFIRM, PRESS THE CENTER BUTTON.



Striker will move on to the next setting.

## NOTICE

Red & Amber blinking lights indicate battery voltage is below 12 volts.

# CONTROLS AND OPERATION

## DASH PANEL

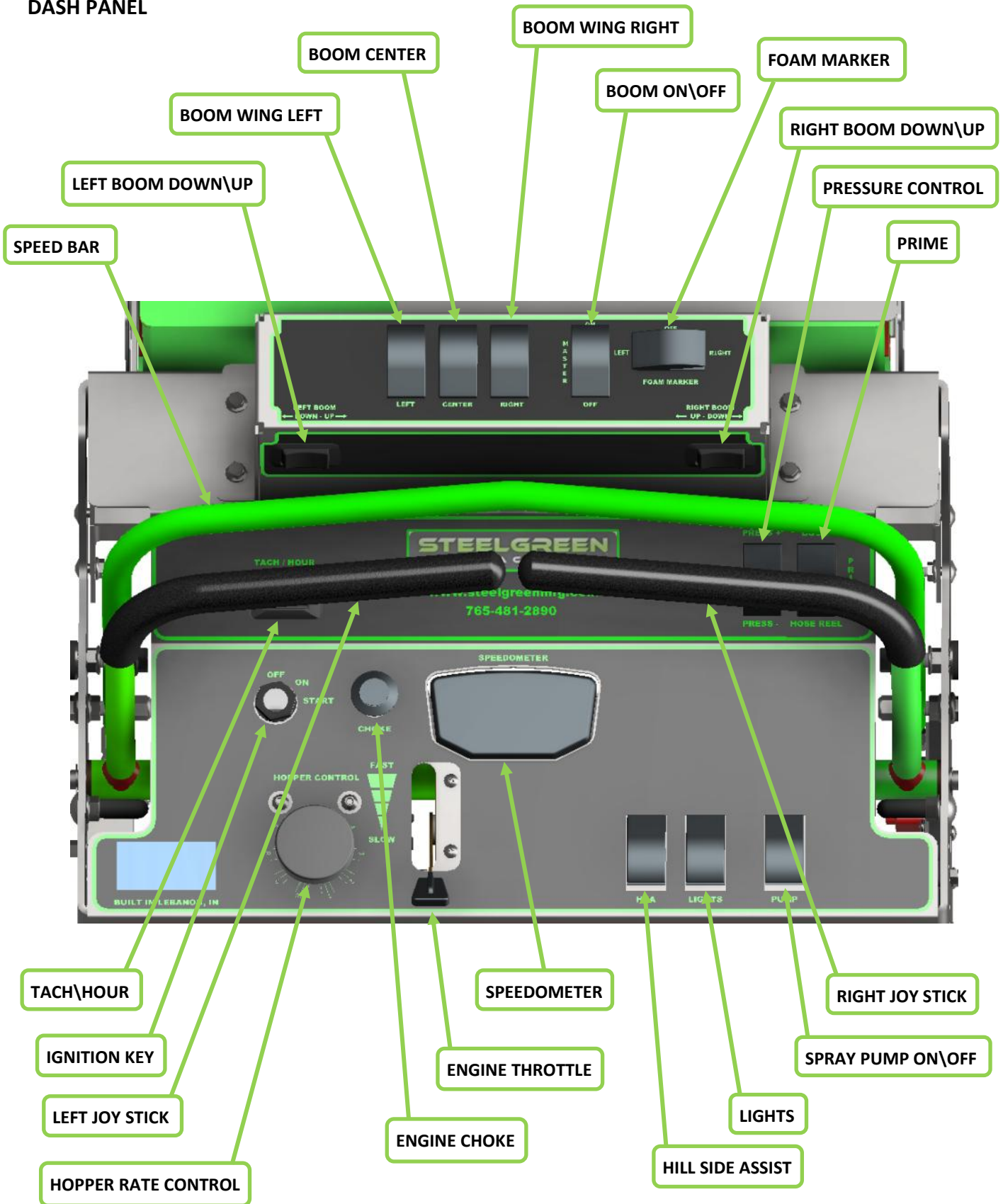

## CONTROLS AND OPERATION

### MACHINE OPERATION:

- To drive the machine, step up on the foot board and rest against the chest pad.

### PARKING BRAKE OPERATION:

- Disengage the parking brake.

CHEST PAD

FOOT BOARD

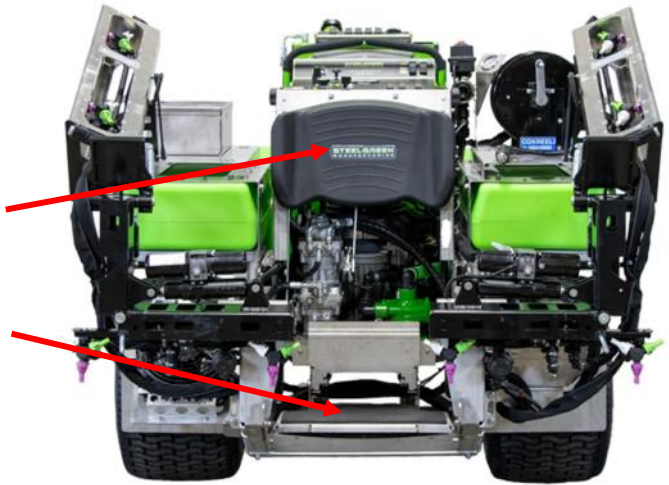

## NOTICE

- To engage the parking brake, push the pedal down.
- To release the parking brake, pull the pedal up.

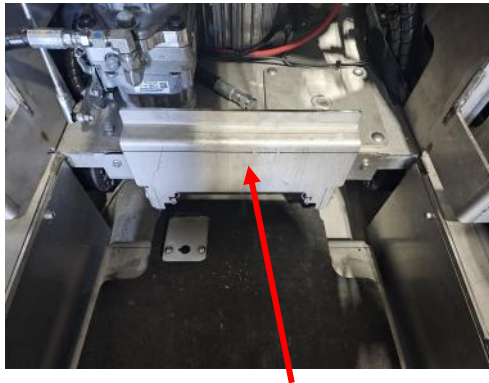

BRAKE DISENGAGED

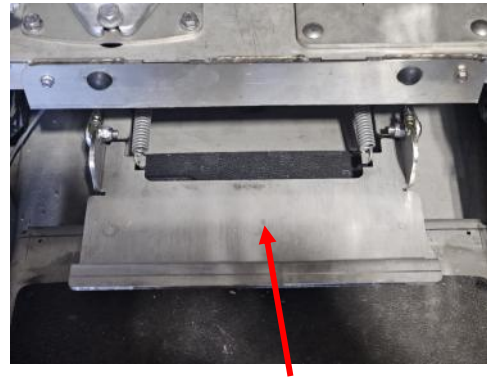

BRAKE ENGAGED

- Move the throttle lever about half throttle.
- Pull the choke out.
- Turn the key to start the machine.
- Push the choke back in once the machine is running.

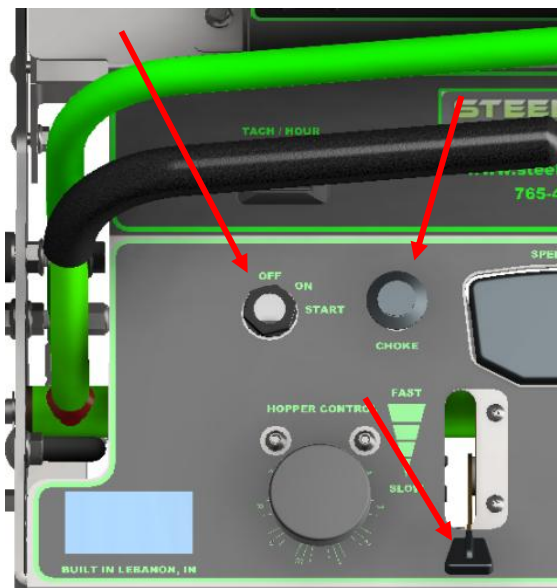

## CONTROLS AND OPERATION

### JOY STICKS:

- The left joy stick maneuvers the left tire forward and reverse.
- The right joy stick maneuvers the right tire forward and reverse.

### DRIVING THE MACHINE:

- Move both joy sticks forward to drive forward.
- Move both joy sticks back to drive in reverse.
- To maneuver a left turn move the right joy stick forward and pull the left one back.
- To maneuver a right turn move the left joy stick forward and pull the right one back.

### LEFT TURN

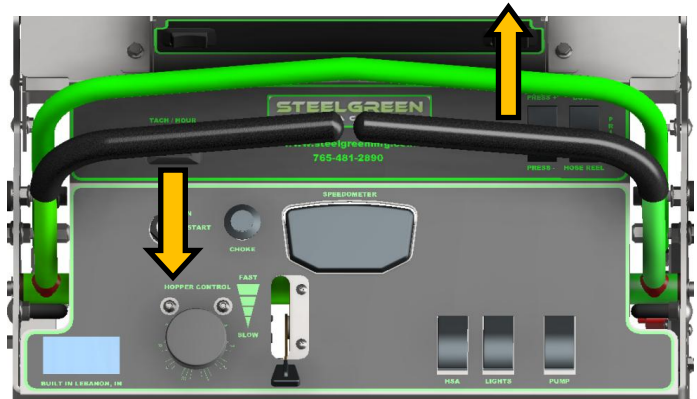

### RIGHT TURN



### SPEED BAR:

- The speed bar is used to set the maximum speed for spray applications.
- Adjust the speed bar by loosening the black knobs on both sides.
- Move both the joy sticks and speed bar together to set the desired max. speed and tighten the knobs.

### SPEED BAR

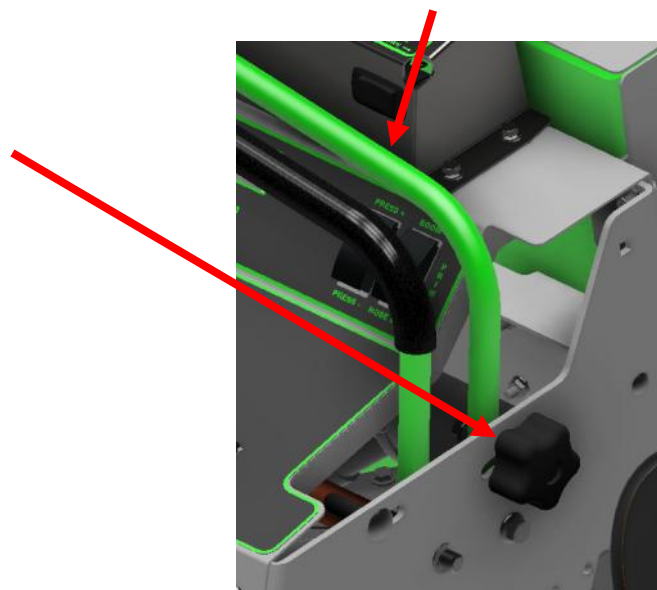

## CONTROLS AND OPERATION

### SPRAY SYSTEM:

**STEP 1:** Lower the spray booms.

The spray boom consists of 3-sections: *Left Wing, Left Center Section, & Right Wing (see below).*

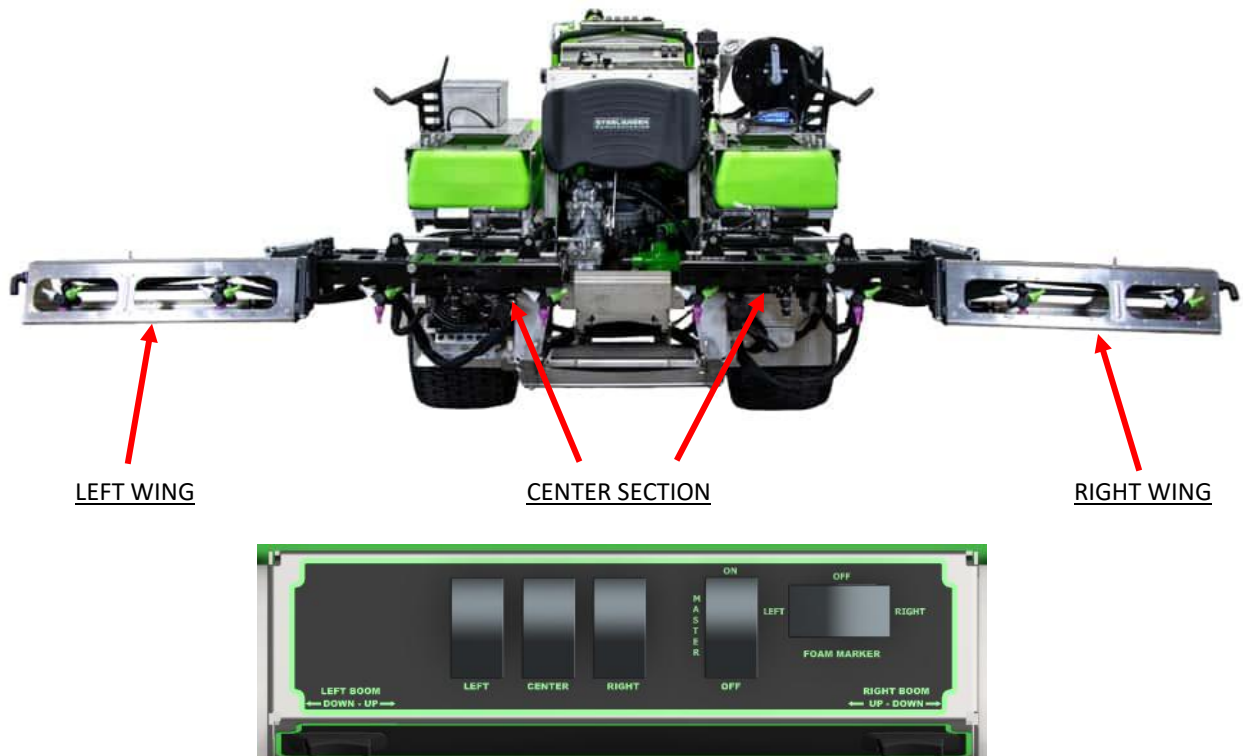

- Each boom section\wing holds 2 nozzles.

## NOTICE

*For extended cylinder life do NOT exceed a duty cycle no more than 30 seconds on & off for at least 90 seconds.*

- The spray boom can be raised or lowered individually by pressing the up\down buttons. You can stop the booms at level or they can be positioned  $-15^\circ$  for hill side spray (see Fig. 1).
- The foam marker is also controlled individually left or right boom by pressing the foam marker button left or right.

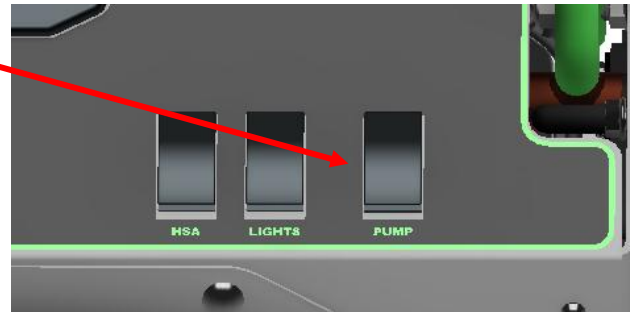

Fig. 1

## CONTROLS AND OPERATION

### STEP 2:

- To turn the spray pump on, press the pump switch to the “on” position.



- Turn the spray boom to the “on” position.



- Set the prime switch to the “boom” position. See next page for hose reel operation.

- Set the spray pressure - Increase or decrease the spray pressure by pressing the pressure switch “press +” or “press -”



### NOTICE

You can increase or decrease the spray pressure one psi at a time by bumping the switch or press and hold the switch + or - to increase or decrease spray pressure.

- Use the **Spray Calibration Chart** to determine the desired spray pressure.
- spray pressure is measured by the pressure gauge.
- If the tank is out of liquid press the prime switch to hold the system wide open to prime. Once the prime switch is off it will return to desired spray pressure.

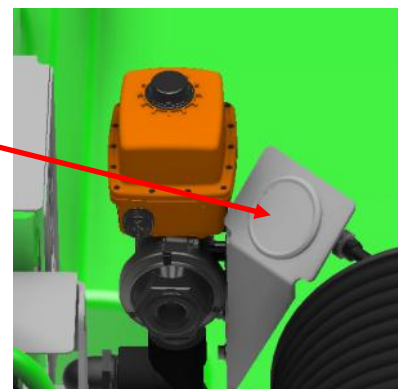

## CONTROLS AND OPERATION

- The SGXL model is equipped with a 100' hose reel. This is meant to assist with spot spraying and or areas that are not able to be reached by the machine.
- To operate, engage the hose reel, make sure the boom switches are turned off. And move the prime switch to the "hose reel" position.
- Set the spray pressure - Increase or decrease the spray pressure by pressing the pressure switch "press +" or "press -"

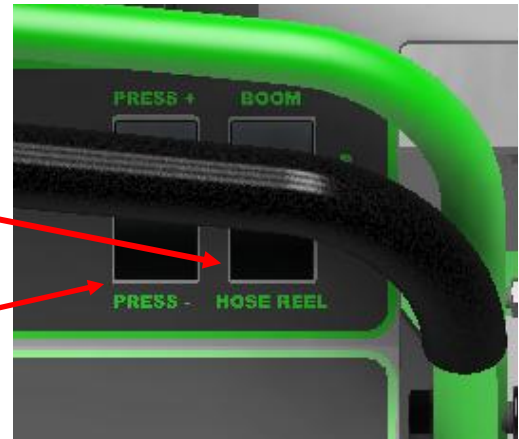

### NOTICE

*You can switch back & forth between the spray boom & hose reel. The computer will remember were the pressure is set.*

- spray pressure is measured by the pressure gauge.
- Use the proper pressure dictated in the *Spray Calibration chart*.
- To activate the hose reel, open the chrome valve.
- Remove the spray gun from the clip, pull the lever back on the spray gun to spray.

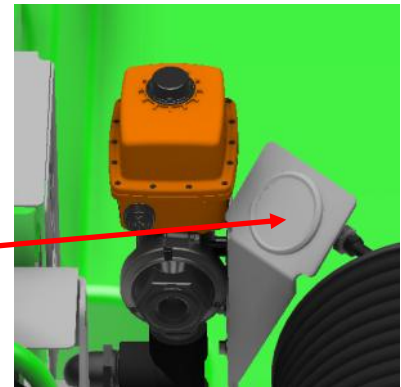

### NOTICE

*Make sure the Hose Reel Valve is turned off while not in use. Otherwise back pressure may be created and will cause the nozzle tips to drip.*





CONTROLS AND OPERATION

TIP PART NO. (STRAINER MESH SIZE)	PSI	DROP SIZE	CAPACITY ONE TIP IN GPM	CAPACITY ONE TIP IN OZ/MIN	APPLICATION RATE FOR 20" SPRAY TIP SPACING									
					GALLONS PER ACRE (GPA)				GALLONS PER 1,000 SQ. FT.					
					4 MPH	5 MPH	6 MPH	8 MPH	3 MPH	4 MPH	5 MPH	6 MPH	7 MPH	8 MPH
AIC11002 (50)	30	XC	0.17	22	12.6	10.1	8.4	6.3	0.39	0.29	0.23	0.19	0.17	0.14
	40	XC	0.20	26	14.9	11.9	9.9	7.4	0.45	0.34	0.27	0.23	0.19	0.17
	50	VC	0.22	28	16.3	13.1	10.9	8.2	0.50	0.37	0.30	0.25	0.21	0.19
AIC110025 (50)	30	XC	0.22	28	16.3	13.1	10.9	8.2	0.50	0.37	0.30	0.25	0.21	0.19
	40	XC	0.25	32	18.6	14.9	12.4	9.3	0.57	0.43	0.34	0.28	0.24	0.21
	50	VC	0.28	36	21	16.6	13.9	10.4	0.63	0.48	0.38	0.32	0.27	0.24
AIC11003 (50)	30	XC	0.26	33	19.3	15.4	12.9	9.7	0.59	0.44	0.35	0.29	0.25	0.22
	40	XC	0.30	38	22	17.8	14.9	11.1	0.68	0.51	0.41	0.34	0.29	0.26
	50	VC	0.34	44	25	20	16.8	12.6	0.77	0.58	0.46	0.39	0.33	0.29
AIC11004 (50)	30	XC	0.35	45	26	21	17.3	13.0	0.79	0.60	0.48	0.40	0.34	0.30
	40	XC	0.40	51	30	24	19.8	14.9	0.91	0.68	0.54	0.45	0.39	0.34
	50	VC	0.45	58	33	27	22	16.7	1.0	0.77	0.61	0.51	0.44	0.38
AIC11005 (50)	30	XC	0.43	55	32	26	21	16.0	0.97	0.73	0.58	0.49	0.42	0.37
	40	XC	0.50	64	37	30	25	18.6	1.1	0.85	0.68	0.57	0.49	0.43
	50	VC	0.56	72	42	33	28	21	1.3	0.95	0.76	0.63	0.54	0.48
AIC11006 (50)	30	XC	0.52	67	39	31	26	19.3	1.2	0.88	0.71	0.59	0.51	0.44
	40	XC	0.60	77	45	36	30	22	1.4	1.0	0.82	0.68	0.58	0.51
	50	VC	0.67	86	50	40	33	25	1.5	1.1	0.91	0.76	0.65	0.57
AIC11008 (50)	30	XC	0.69	88	51	41	34	26	1.6	1.2	0.94	0.78	0.67	0.59
	40	XC	0.80	102	59	48	40	30	1.8	1.4	1.1	0.91	0.78	0.68
	50	XC	0.89	114	66	53	44	33	2.0	1.5	1.2	1.0	0.86	0.76
HIGH VOLUME SPRAY CHART														
AIC11010	30	UC	0.87	111	65	52	43	32	2.0	1.5	1.2	0.99	0.85	0.74
	40	XC	1.00	128	74	59	50	37	2.3	1.7	1.4	1.1	0.97	0.85
	50	XC	1.12	143	83	67	55	42	2.5	1.9	1.5	1.3	1.1	0.95
AIC11015	30	UC	1.30	166	97	77	67	48	2.9	2.2	1.8	1.5	1.3	1.1
	40	XC	1.50	192	111	89	74	56	3.4	2.6	2.0	1.7	1.5	1.3
	50	XC	1.68	215	125	100	83	62	3.8	2.9	2.3	1.9	1.6	1.4

**NOTE:** Always double-check your application rates. Droplet size classification shown is based on ISO 25358. Droplet size classification standard is subject to change. Tabulations are based on spraying water at 70°F.

Mixing of liquid or dry product should be in accordance to manufacturers' labels. This machine is designed for low volume spraying, and the mix will be more concentrated.

This machine is factory set to put down 1/3 gallon of liquid per thousand square feet (at 5 mph and 40 PSI). For instance, some products call for 1.1 to 1.5 ounces per thousand square feet. It is recommended to use 1.3 ounces of product per thousand square feet (median value of 1.1 to 1.5).

If you were filling a 30-gallon tank, your equation would look like:

(Tank Capacity ÷ Spray Rate) x Chemical Rate = Amount of product in tank  
 Example: (30 gal ÷ .34 gal/1 k) x 1.3 oz = 114.7 oz

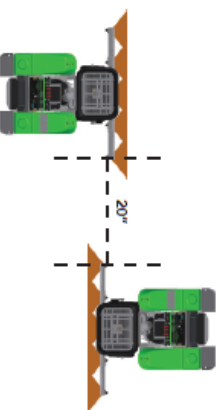

## CONTROLS AND OPERATION

### SPREADER:

#### ATTACHING THE HOPPER TO THE MACHINE

##### STEP 1:

**⚠ DANGER**

*The tank MUST be drained before attempting to lift.*



- Disconnect the suction hose & drain the tank.
- Disconnect the return hose from the manifold.



- Disconnect the suction hose from the pump.
- Pull the suction hose out & make sure the return hose is free from getting caught on anything while lifting the spray system.



## CONTROLS AND OPERATION

### STEP 2:

- Disconnect the relief tube.



### STEP 3: Unplug the pressure sensor & KZ valve.

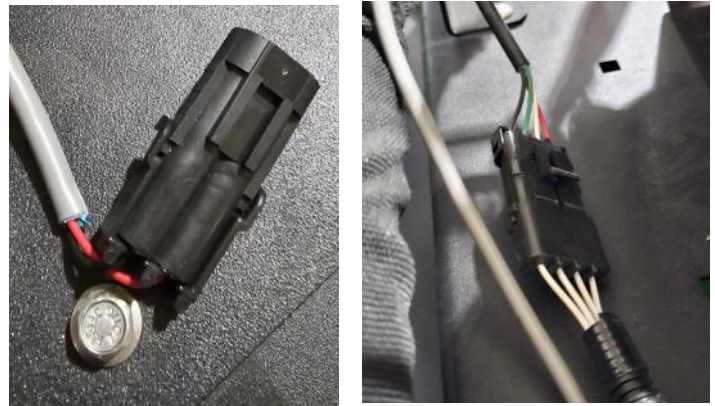

### STEP 4: Remove the (4) bolts securing the spray system to the frame. Repeat this step for the other side.

REAR

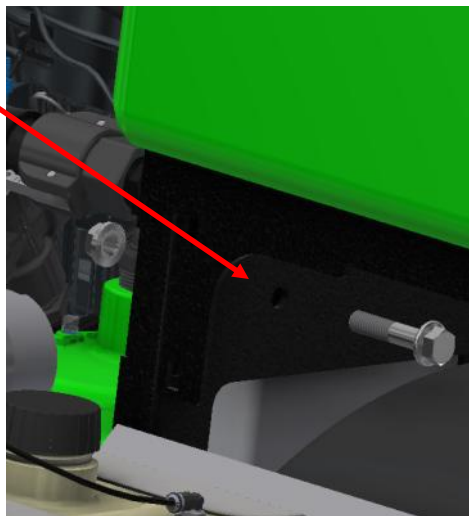

FRONT

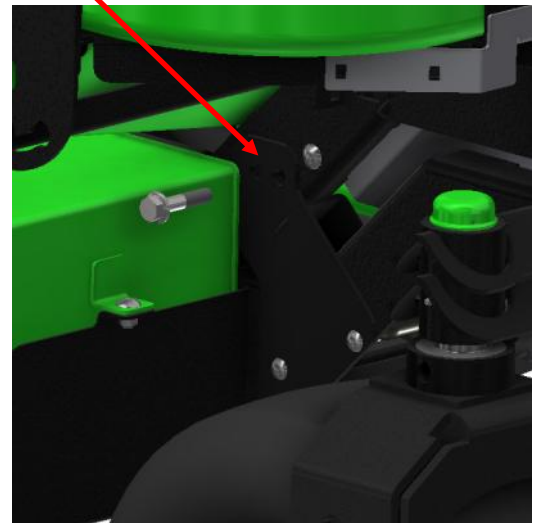

## CONTROLS AND OPERATION

**STEP 5:** Attach a lift to both sides of the spray system.

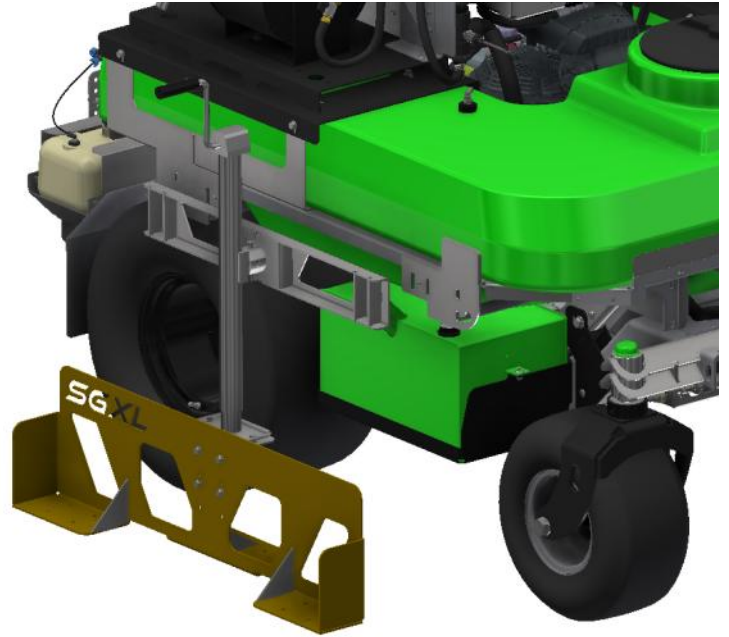

**STEP 6:**

- With the help of a second person, lift the spray system until it clears the frame.

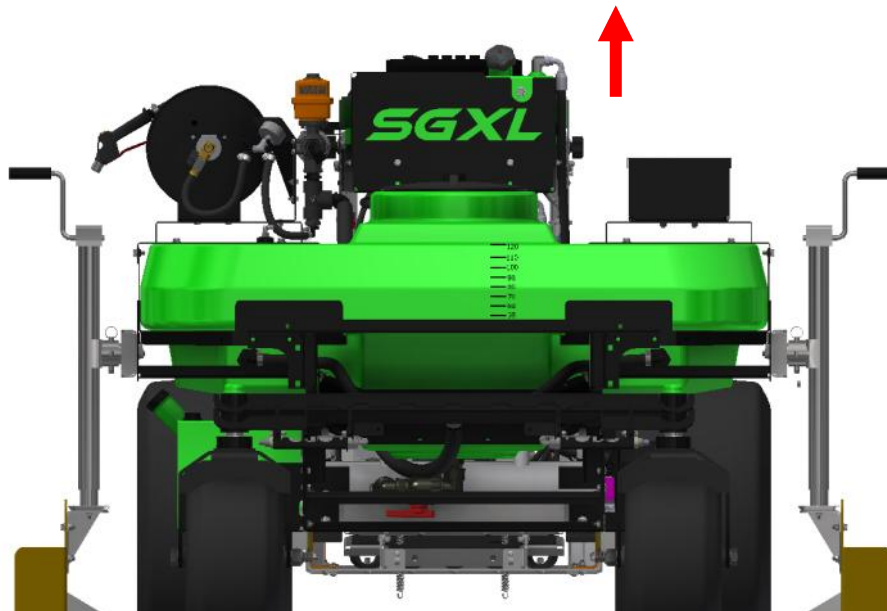

## CONTROLS AND OPERATION

- Once the spray system is clear of the frame, back the machine out from under it.

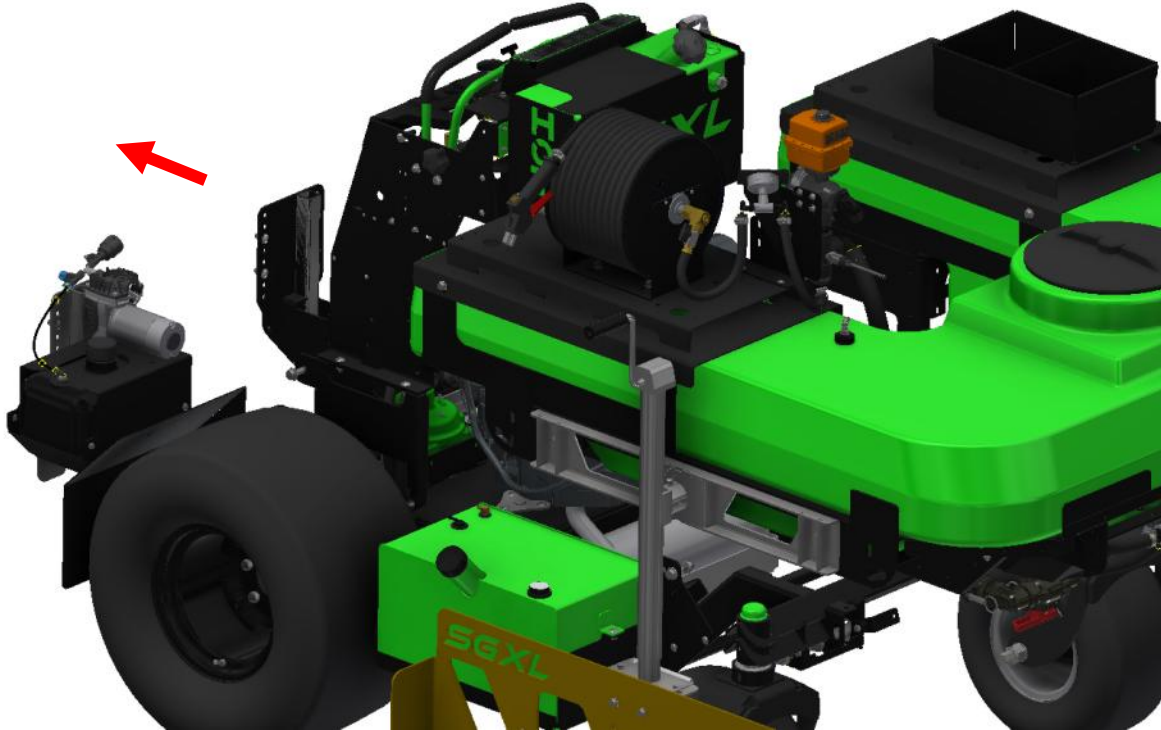

### STEP 7:

- Attach a lift to both sides of the hopper.

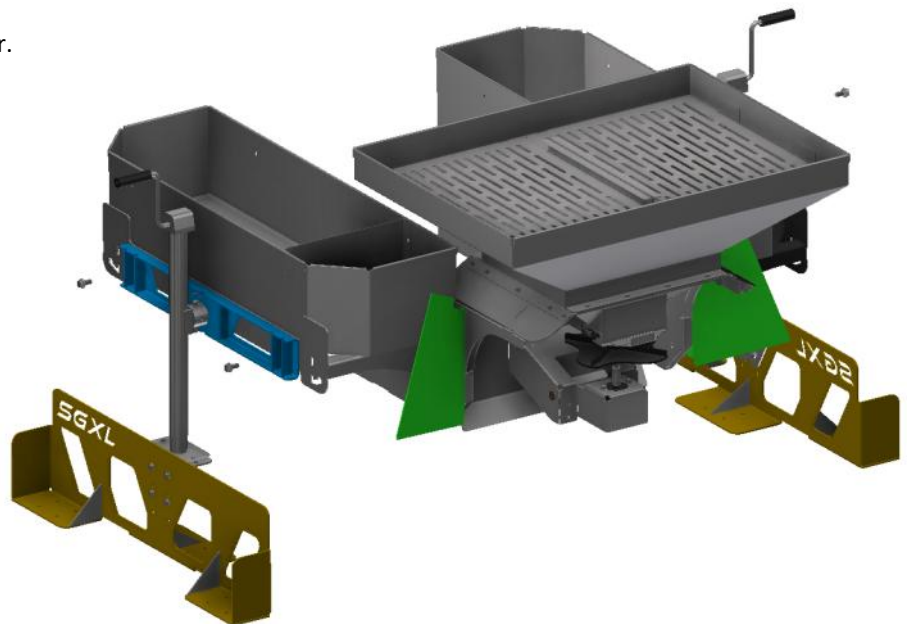

## CONTROLS AND OPERATION

- With the help of a second person, lift the hopper until it clears the frame of the machine.

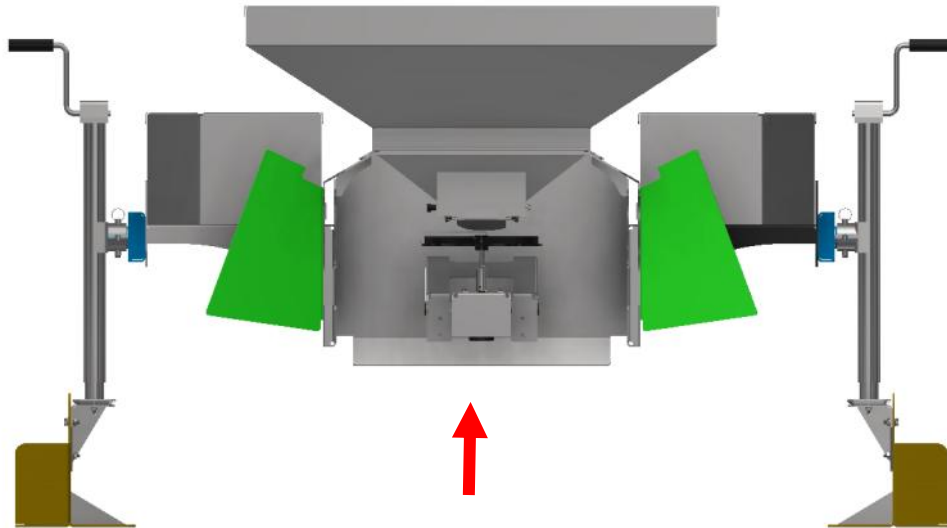

**STEP 8:** Carefully drive the machine in place under the hopper.



## CONTROLS AND OPERATION

**STEP 9:** With the help of a second person, lower the hopper onto the frame. Be sure the holes are lined up with the hopper and the frame.

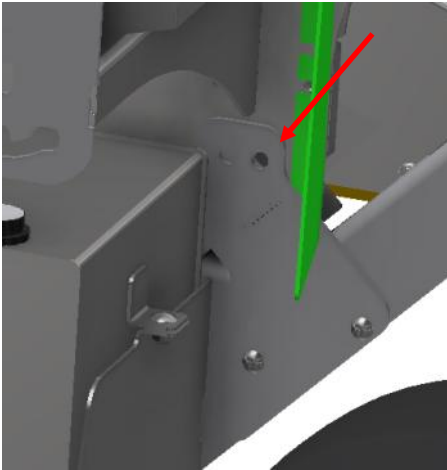

**STEP 10:** Attach the bolts securing the hopper to the frame.  
*Repeat this step for the other side.*

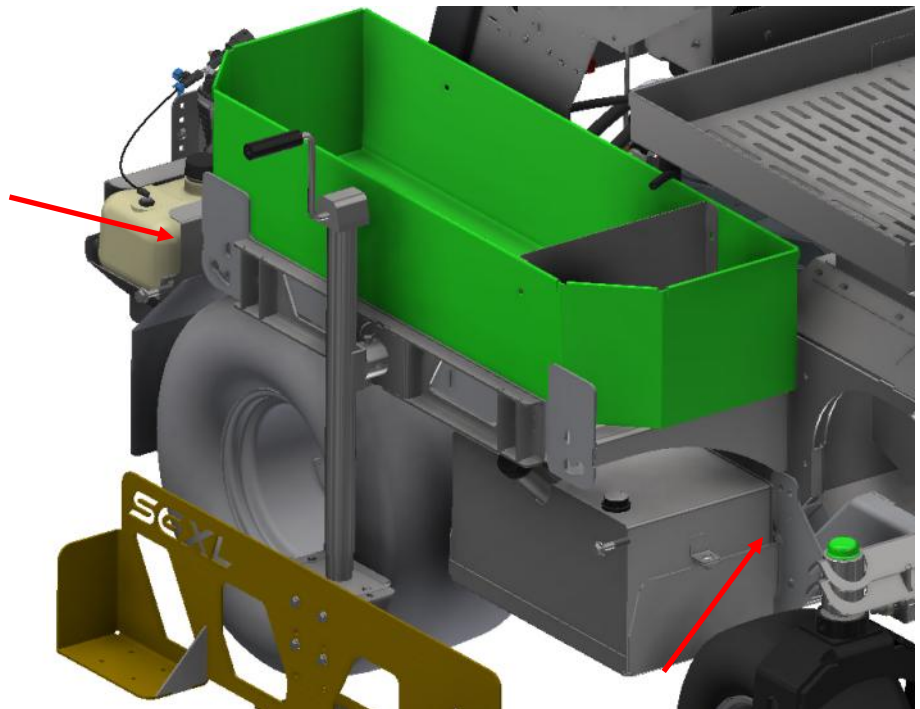

## CONTROLS AND OPERATION

**STEP 11:** Connect the hopper hoses to the quick connects on the machine.

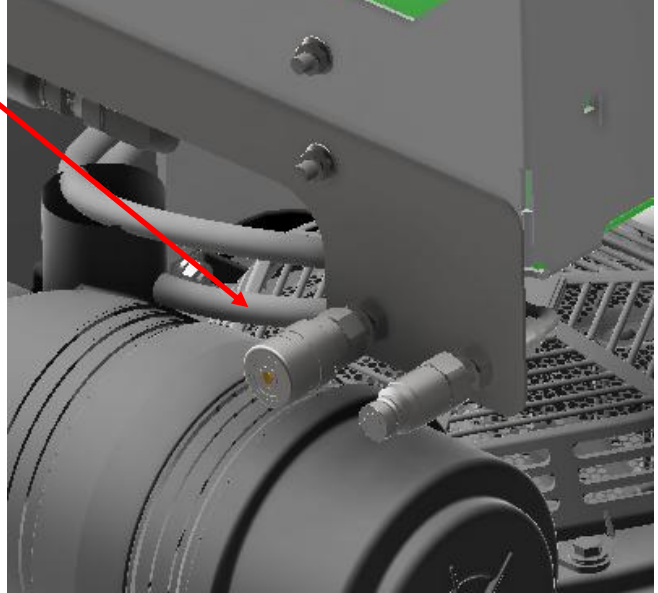

### STEP 12:

- Connect the harness from the switch to the plug on the hopper.



- Connect the headlight to the plug on the front of the machine.

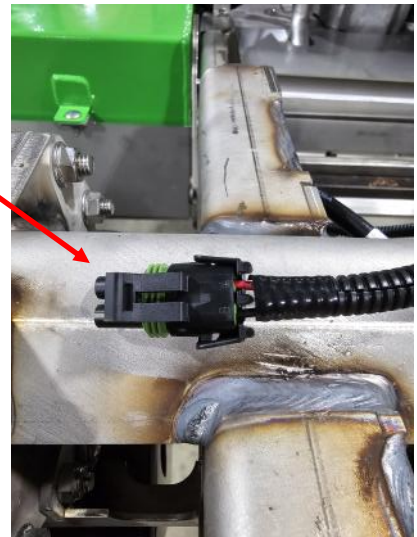

## CONTROLS AND OPERATION

### STEP 13:

- Attach the end of the control cable to the bracket on the control assembly.
- Attach the clevis to the lever bracket.

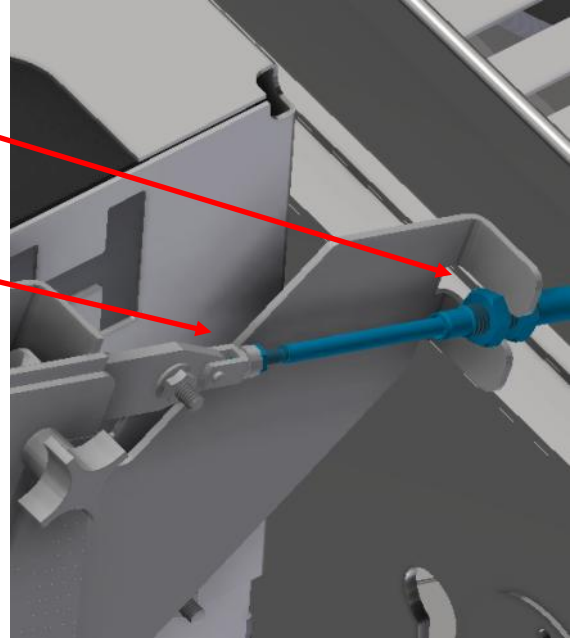

### OPERATION:

- Turn the handle on the valve to direct the foam marker fluid to the front dropper.

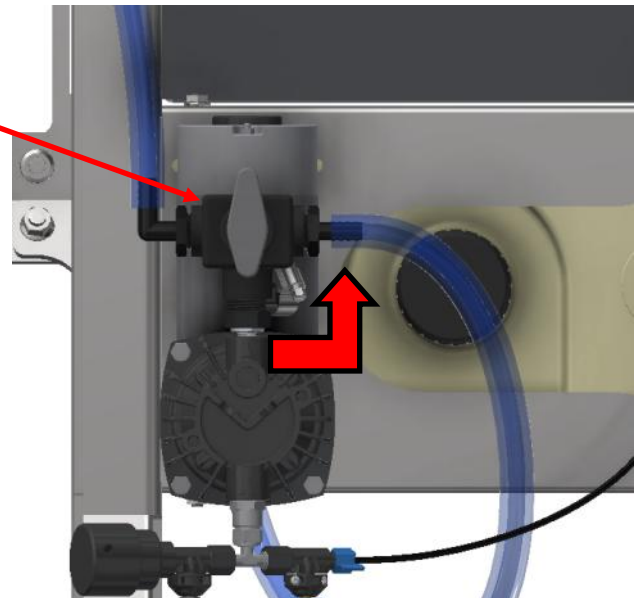

## CONTROLS AND OPERATION

- Loosen the knob to select the desired gate opening and retighten the knob.
- Move the lever to open and close the gate.

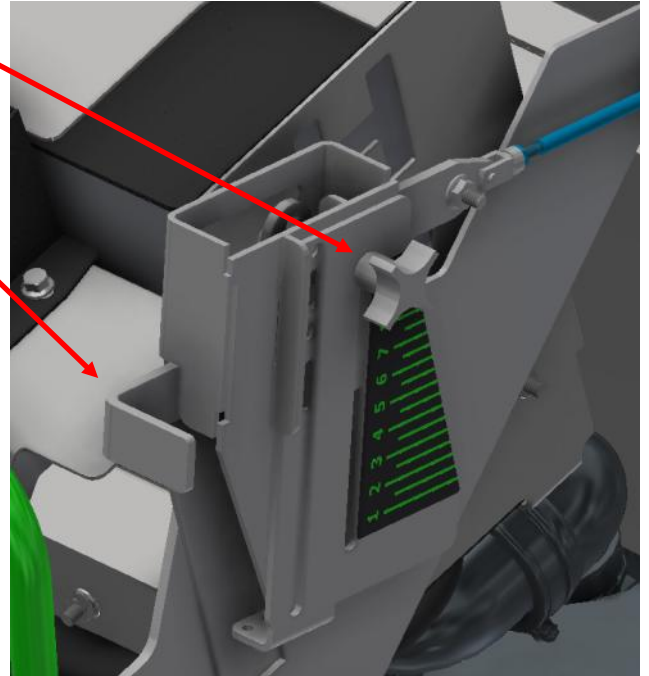

- Turn the knob on the control valve to adjust the hopper speed.

- Press the switch to activate the agitator.

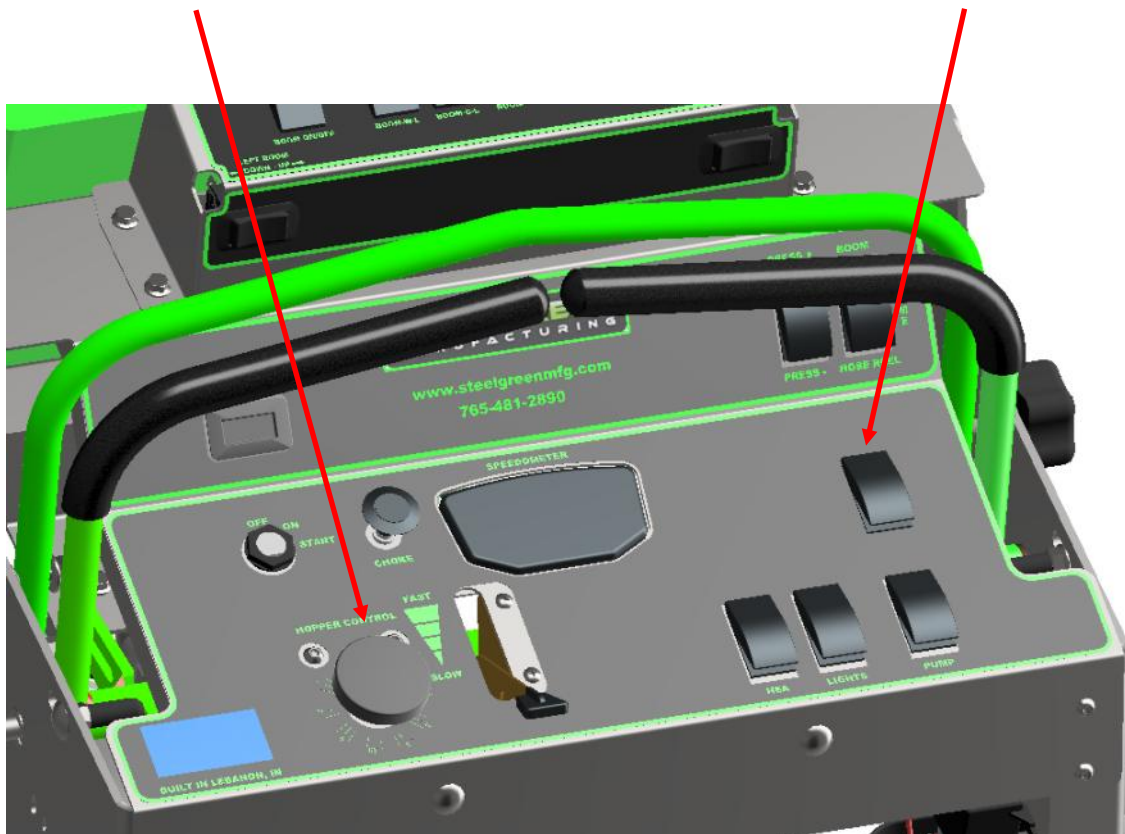

## CONTROLS AND OPERATION

### SPREADER:

#### CAUTION

- *To avoid injury to the hand, ensure the engine is turned OFF before adjusting.*
  - *Wear appropriate clothing & safety equipment when applying & handling chemicals.*
- 
- Accuway balances the spread pattern by shifting the product placement on the spinner. Placing the product on the impeller close to the shaft or the center will cause the spread pattern to be heavier to the right as it rides the impeller for a longer period. If the product is placed on the outer edge of the impeller, the spread pattern will be heavier to the left as the spinner turns clockwise.
  - Start with the Accuway control cable all the way forward or in.
  - Begin to spread the product. As you are spreading, you should be able to see the spread pattern in front of you. Generally, all spreaders will tend to throw fertilizer heavy to the right. As you continue to spread, pull the Accuway control towards you very slowly in small increments. This will bring the spread pattern dead center in front of you.
  - Once you have the spread pattern “dead center,” lock the Accuway cable in place. There should be no reason to reset the Accuway for that product unless you see the spread pattern has changed due to bumping the lever. If it has changed slightly, simply readjust the pattern as you are spreading.

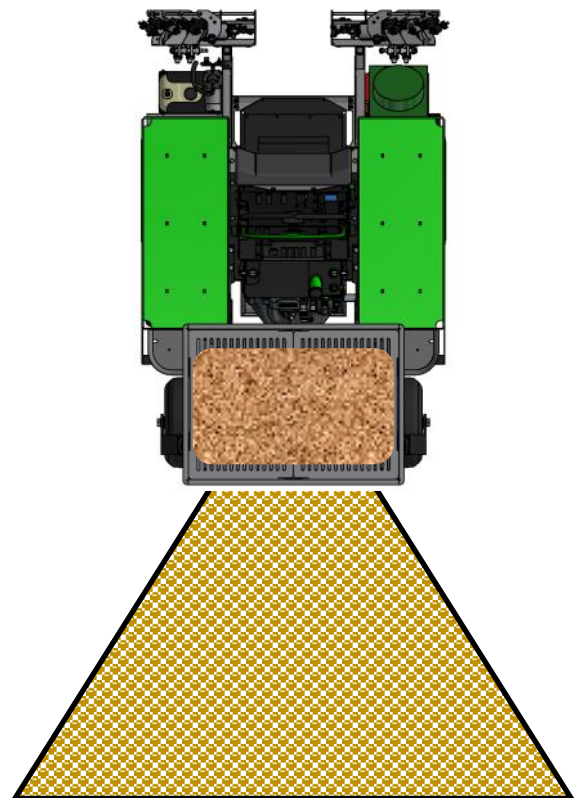

**THROW FERTILIZER  
TO CENTER OF TIRE  
TRACKS**



## CONTROLS AND OPERATION

### BASIC CALIBRATION CHART:

		Spread Width (Feet)									
		6	8	10	12	14	16	18	20	22	24
Speed		Bucket Catch Time (Seconds)									
		8 mph	7.5 mph	7 mph	6.5 mph	6 mph	5.5 mph	5 mph	4.5 mph	4 mph	3.5 mph
	8 mph	28.5	21.4	17.1	14.2	12.2	10.7	9.5	8.5	7.8	7.1
	7.5 mph	30.3	22.7	18.2	15.2	13	11.4	10.1	9.1	8.3	7.6
	7 mph	32.4	24.3	19.4	16.2	13.9	12.1	10.8	9.7	8.8	8.1
	6.5 mph	35	26.2	21	17.5	15	13.1	11.7	10.5	9.5	8.7
	6 mph	37.9	28.4	22.7	18.9	16.2	14.2	12.6	11.4	10.3	9.5
	5.5 mph	41.4	31	24.8	20.7	17.7	15.5	13.8	12.4	11.3	10.3
	5 mph	45.7	34.2	27.4	22.8	19.6	17.1	15.2	13.7	12.5	11.4
	4.5 mph	50.5	37.9	30.3	25.3	21.6	18.9	16.8	15.2	13.8	12.6
	4 mph	56.5	42.4	33.9	28.2	24.2	21.2	18.8	16.9	15.4	14.1
	3.5 mph	65	48.7	39	32.5	27.8	24.4	21.7	19.5	17.7	16.2
	3 mph	75.8	56.8	45.5	37.9	32.5	28.4	25.3	22.7	20.7	18.9

$1,000 \text{ sq ft.} \div \frac{1}{2} \text{ spread width} \div \text{speed in fps} = \text{calibration time}$

## NOTICE

To perform a granular calibration you will need a tape measure, bucket, and a scale.

- First - you will need to weigh the empty bucket and zero your scale (or note the weight of the bucket to subtract from your later measurement).
- Second - remove your spinner and place the bucket under the hopper. Place your white dial on setting number 5 (this is just a starting point). Using the above chart find the time you will need to open your hopper based on your desired speed and spread width.
- Third - open your hopper for the appropriate amount of time and then weigh the bucket (remember to subtract the weight of the empty bucket). Adjust the dial knob up or down and repeat until you have your desired lbs. per 1 thousand square feet (example if you want 4lbs per 1k sq. ft. you should have 4lbs of product in the bucket).
- Forth - stretch a tape measure out to your desired width on the ground in front of the machine and briefly open your hopper and adjust your spread width to match the width of your tape measure.

Your hopper is now calibrated. When applying product be sure to throw back to the center of your tire tracks from your previous pass. If needed use the Accuway diffuser to adjust your pattern so that the heaviest amount of product is directly in front of the machine.

## SPREADER CLEANING

- Use appropriate footwear, eye protection, and clothing when cleaning the spreader.
- The key to years of trouble-free service is to keep your spreader clean and dry.
- Never allow material to remain in hopper for extended periods of time.
- Empty material from hopper at the end of each day. See page 12 for hopper drain instructions.
- Use a hose or wipe excess material off of the spreader at the end of each day.
- Open and close the gate as you rinse to avoid buildup of material.
- Quickly towel dry the spreader.

## CONTROLS AND OPERATION

### HOPPER DRAIN INSTRUCTIONS

**STEP 1:** Remove the (4) bolts from the hopper motor assembly & rotate the assembly down to clear the gate.

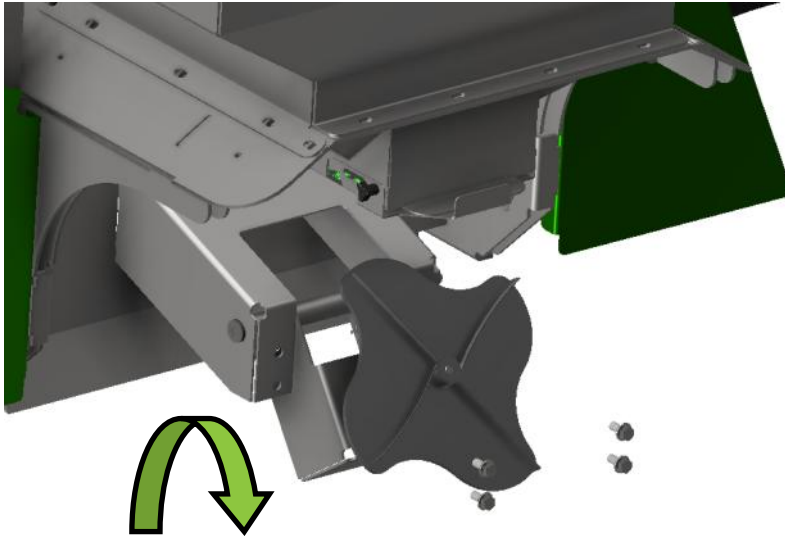

**STEP 2:** Place a bucket or tub under the gate & open it to drain the hopper.

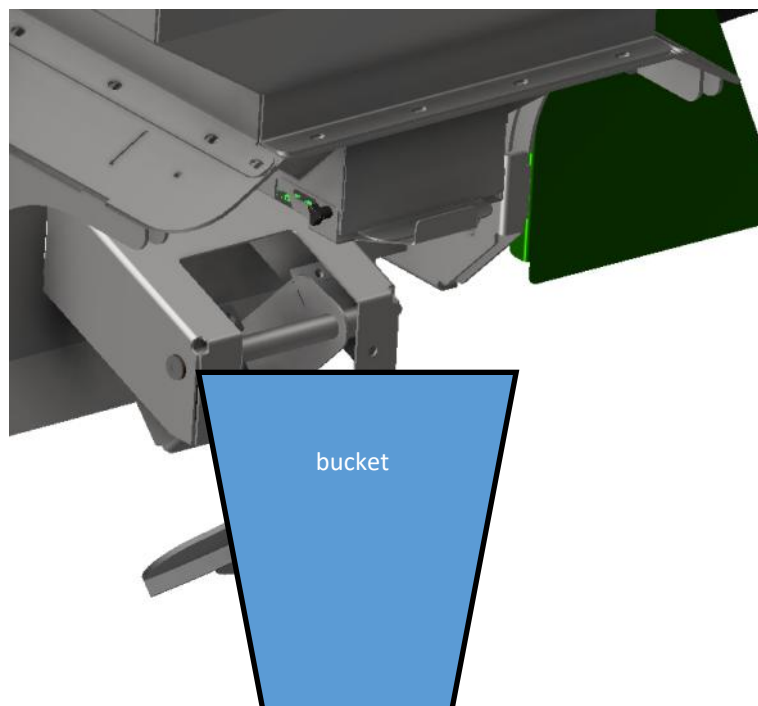



## CARE & MAINTENANCE

### **WARNING**

- *Do not operate the engine in a confined space where carbon monoxide and other fumes can accumulate.*
- *Never lubricate, service, or adjust the machine or spreader while it is moving or running.*
- *Keep hands, feet, clothing, hair, and loose items away from any moving parts.*

### **CAUTION**

- *Understand service and maintenance procedure before performing any work on this machine or spreader.*
- *Disconnect the battery before making any repairs.*
- *Keep all parts in good condition & operating properly.*
- *Fix damages immediately. Replace all worn or damaged parts.*
- *Check all hardware at frequent intervals to ensure they are tight.*

### **MAINTENANCE TIPS**

- Always avoid letting product sit in the tank and pump for an extended period of time.
- Blowing off unit is preferred over washing. But if washing unit dry it off as best as possible.
- Refer to engine owner's manual for all other specs.

### **WINTERIZATION:**

Proper winterization of the spray system helps to prevent damage to the system due to wintertime freezing. Follow these easy steps:

- 1 Drain all of the remaining liquid from the tank and spray system.
- 2 Fill the tank with enough RV antifreeze to fill the entire system.
- 3 Turn on the liquid pump and open all boom valves until solution is visible out of spray nozzles. Close boom valves.
- 4 Open valve for hose reel and begin spraying solution thru the nozzle.
- 5 Put the recommended amount of fuel stabilizer & (follow label for instructions).



## CARE & MAINTENANCE

SUGGESTED SERVICE	ACTION	DAILY	WEEKLY	BI-WEEKLY	MONTHLY	YEARLY	HOURS
Front Caster Wheels	Grease (see next page)				X		
Front Caster Yoke	Grease (see next page)				X		
Front Tire Pressure	24PSI		X				
Front Tire Bearing	Preload				X		
Rear Tire Pressure	26PSI		X				
Rear Lug Nut	Torque 75Lbs				X		
Rear Hub Castle Nut	Check the cotter pin				X		
Frame Hardware	Check all bolts & fasteners				X		
Idler Pulley Arm	Grease (see next page)				X		
Belt Wear	Cracks, Tears, Missing Material				X		
Hopper Cables	Lubricate w/Silicone spray		X				
Accuway Cable							
Deflector Shield cable							
Hopper Bottom Bushing	Change if needed <i>Clean Spinner Daily</i>				X	Replace	
Hopper Spinner				X			
Engine Carburetor	Lube Cable Linkages			X			
Engine Oil	Check	X					100 Hrs.
	Change						
Engine Air Filter	Check/Change if needed		X			Replace	
Engine Air Pre-Filter							
Engine Fuel Filter							
Engine Spark Plugs							
Hydraulic Oil	Change						500 Hrs.
Hydraulic Oil Filter							
Hydraulic Oil Level	Check	X					
Hydro System Fittings	Check for leaks		X				
Chemical Leaks	Check	X					
Spray Nozzle Tips							
Spray Nozzle Tip Screens							
Spray Gun Tip							
Spray Nozzle Gasket							
Spray System Hoses				X			
In-Line Filter				X			
In-Line Filter Gasket				X			
Spray Gun Hose Reel					X		
<b>SGXL FERT SYSTEM</b>	<b>BLOW FERT OFF DAILY</b>						

The suggested maintenance schedule above is recommended for normal use, maintenance will vary for heavier use. Steel Green Mfg. reserves the right to determine usage.

## CARE & MAINTENANCE

### GREASE POINTS:

There are 11 grease points on the XL machine.

1 on each front tire.

1 on each of the caster tubes.

1 on the idler arm.



IDLER ARM GREASE POINT

CASTER TUBE GREASE POINT

(BOTH SIDES)

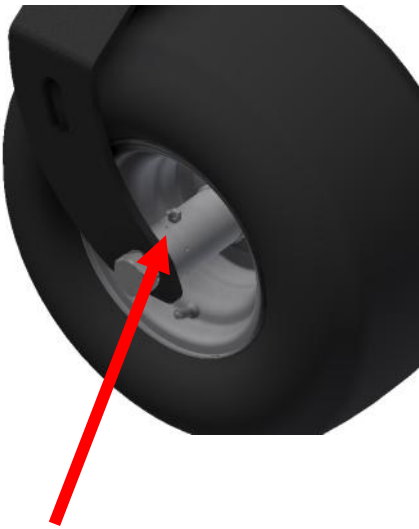

TIRE GREASE POINT  
(BOTH FRONT TIRES)

## CARE & MAINTENANCE

3 on each spray boom (3 hinge points).

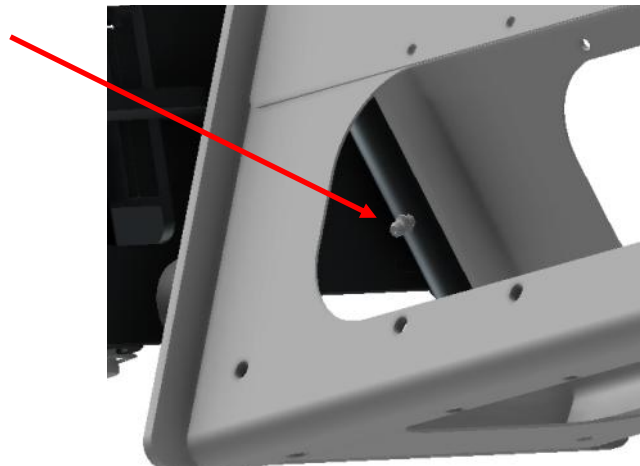
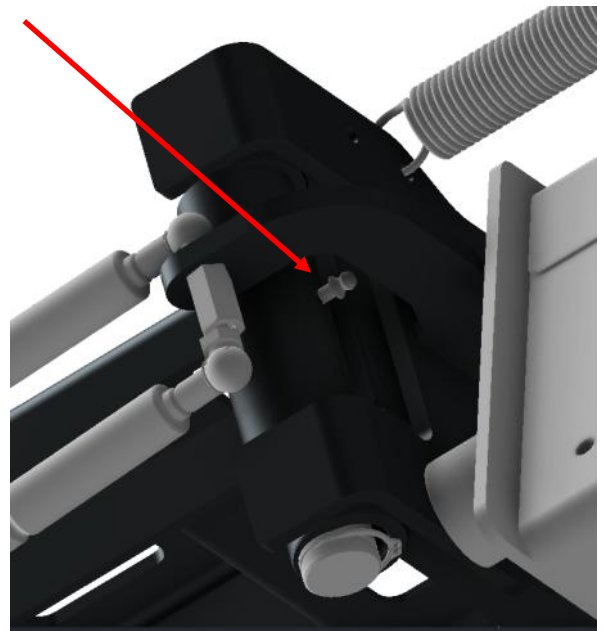
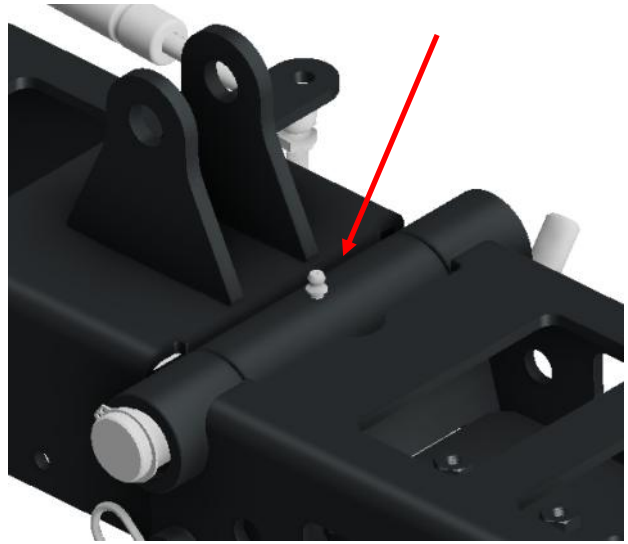

## CARE & MAINTENANCE

### ENGINE OIL CHANGE:

**STEP 1:** Loosen and remove the engine oil “dip stick”.

#### NOTICE

*Change engine oil every 100 hours with 5w50 full synthetic oil, API service classification SN, Resource conserving; ILSAC GF-5.*

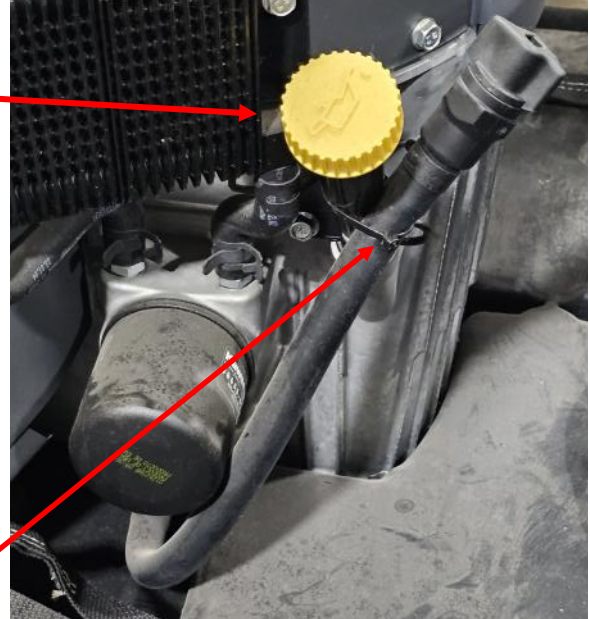

### STEP 2:

- Remove the engine oil drain hose from the zip-tie & drop it down through the opening in the frame.
- Place the hose over a proper container, remove the plug to drain the engine oil.
- Once the oil has been drained, reinstall the plug and re-attach the hose.

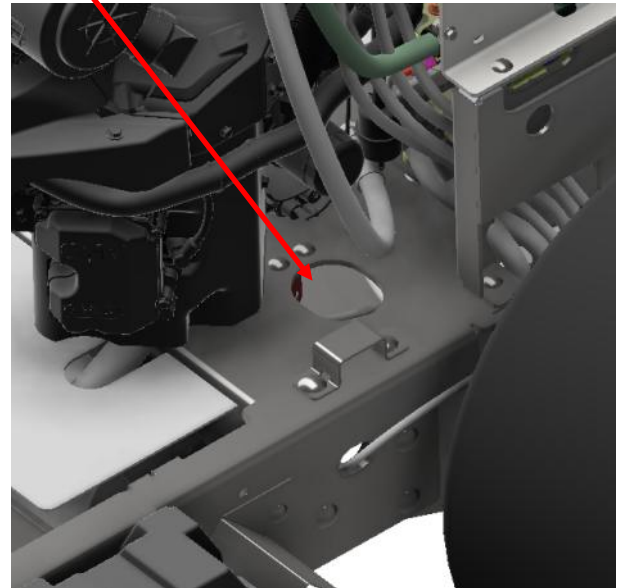

## CARE & MAINTENANCE

**STEP 3:** Remove and replace the engine oil filter.



OIL FILTER

**STEP 4:** Refill the engine oil to the proper level (1.93Qts. MAX.) with 10w30 full synthetic.



## CARE & MAINTENANCE

### HYDRAULIC OIL CHANGE:

**STEP 1:** Loosen and remove the fill cap.

#### NOTICE

*Change hydraulic oil every 500 hours with 5w50 full synthetic oil, API service classification SN, Resource conserving; ILSAC GF-5.*

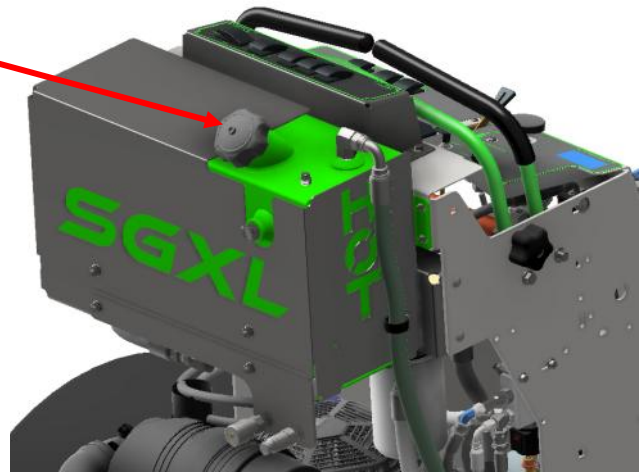

### STEP 2:

- Locate the hydraulic oil drain hose & drop it down through the opening in the frame.
- Place the hose over a proper container, remove the plug to drain the engine oil.

#### CAUTION

*It may be necessary to stop the oil drain & empty the pan more than once.*

- Once the oil has been drained, reinstall the plug & place the hose back behind the engine.

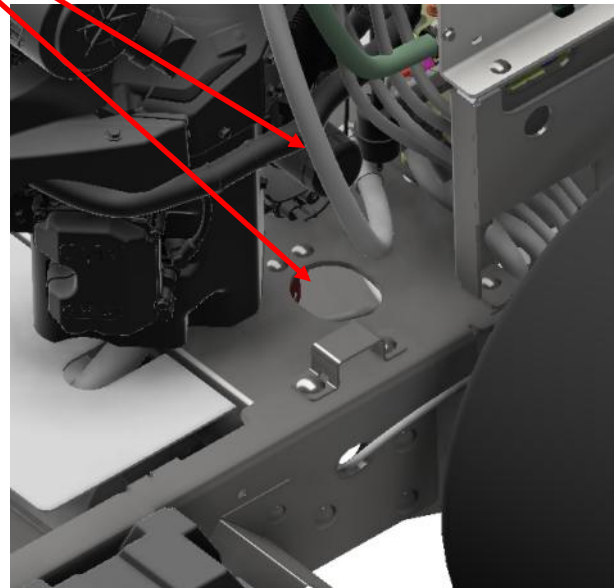

## CARE & MAINTENANCE

### STEP 3:

- Refill the hydraulic oil tank until the oil appears at the bottom of the sight glass. (10w30 full synthetic.)
- Once the tank is full, reinstall the fill cap.

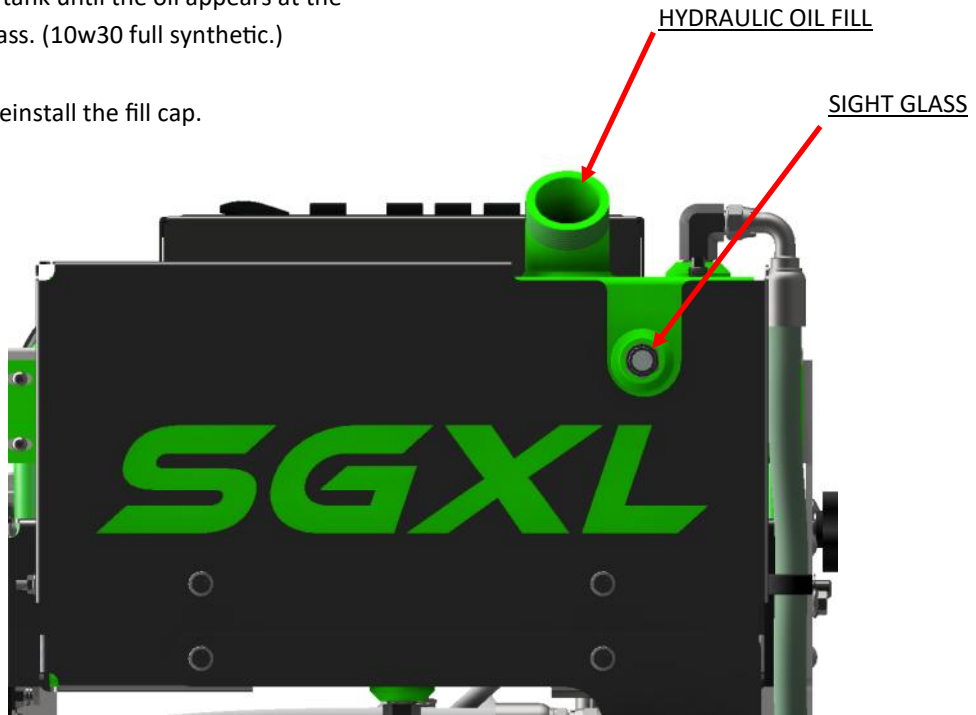



NOTES



NOTES

## Steel Green Manufacturing, LLC

### 1-Year Limited Warranty

**A. WHAT IS COVERED** – This Warranty applies to equipment having model numbers SGXL (“Equipment”) manufactured by Steel Green Manufacturing, LLC, an Indiana limited liability company (“Steel Green”). This Warranty only applies to Equipment purchased directly from Steel Green or an authorized dealer or distributor of the Equipment (“Authorized Dealers”) in the United States. Except for Excluded Parts (as hereinafter defined), Steel Green agrees to repair or replace, at its option, any original component of the Equipment that is defective in material or workmanship (collectively “Warranty Service”). This Warranty begins on the date the product is delivered to the original purchaser and continues for a period of twelve (12) months thereafter (the “Warranty Term”).

**B. WHAT IS NOT COVERED** – This Warranty does not apply to the following categories of equipment: (1) used Equipment, unless there has been an Approved Transfer (as hereinafter defined); or (2) Equipment that has been altered or modified in ways not approved by Steel Green, including, but not limited to, setting injection pump fuel delivery above specifications stated in the owner’s manual. Furthermore, this Warranty does not apply to damage due to any of the following: (1) normal wear and tear; (2) the failure to perform reasonable and proper maintenance; (3) the failure to follow instructions and recommendations in the owner’s manual; (4) negligent or intentional misuse; (5) failure to properly store the Equipment; (6) vandalism; (7) the elements and inclement weather; or (8) collision or accident. “Excluded Parts” means the following parts, which are not covered by and are expressly excluded from this Warranty: (1) consumable parts, such as oil, filters, belts, brakes, and spark plugs; (2) tires; (3) batteries; and (4) the engine. The manufacturers of the Excluded Parts may provide a separate warranty. See manufacturers’ manuals for details.

**C. WHO IS COVERED** – This Warranty extends to the original purchaser of the Equipment who completes and returns the warranty registration card included with the Equipment to Steel Green and to any subsequent owner (collectively “you”), provided the subsequent owner notifies Steel Green of the change in ownership and Steel Green approves the transfer of this Warranty (“Approved Transfer”). An Approved Transfer does not extend the Warranty Term.

**D. HOW IS WARRANTY SERVICE OBTAINED** – To obtain Warranty Service, you must: (1) report the Equipment defect to Steel Green within the Warranty Term; and (2) deliver the Equipment for Warranty Service within a reasonable time thereafter. All Warranty Service must use new or remanufactured parts or components furnished or approved by Steel Green and must be performed by Steel Green, an Authorized Dealer, or a service center approved by Steel Green (“Authorized Service Center”), as directed

STEEL GREEN'S ONLY LIABILITY WITH RESPECT TO THIS WARRANTY AND YOUR EXCLUSIVE REMEDY SHALL BE FOR THE REPAIR OR REPLACEMENT OF PARTS AS SET FORTH HEREIN. NO CLAIM FOR BREACH OF WARRANTY SHALL ENTITLE YOU TO CANCELLATION OR RESCISSION OF THE PURCHASE OF THE EQUIPMENT.

IN NO EVENT WILL ANY AUTHORIZED DEALER, ANY AUTHORIZED SERVICE CENTER, STEEL GREEN OR ANY COMPANY AFFILIATED WITH STEEL GREEN BE LIABLE FOR INCIDENTAL OR CONSEQUENTIAL DAMAGES. Examples of such damages include, but are not limited to: (1) the loss or damage to person or property other than that covered by this Warranty; (2) attorneys' fees; (3) claims for lost revenue or lost profits; and (4) rental costs of similar equipment to the Equipment.

SOME STATES DO NOT ALLOW THE EXCLUSION OR LIMITATION OF INCIDENTAL OR CONSEQUENTIAL DAMAGES, OR LIMITATIONS ON THE DURATION OF AN IMPLIED WARRANTY, SO THE ABOVE LIMITATIONS AND EXCLUSIONS MAY NOT APPLY TO YOU. THIS WARRANTY GIVES YOU SPECIFIC LEGAL RIGHTS, BUT YOU MAY ALSO HAVE OTHER RIGHTS, WHICH VARY FROM STATE TO STATE.

**F. NO OTHER WARRANTIES** – NO OTHER PERSON OR ENTITY, INCLUDING ANY AUTHORIZED DEALER, HAS AUTHORITY TO MAKE ANY WARRANTY, REPRESENTATION, CONDITION OR PROMISE ON BEHALF OF STEEL GREEN, OR TO MODIFY THE TERMS OR LIMITATIONS OF THIS WARRANTY IN ANY WAY, WHETHER ORALLY OR IN WRITING. STEEL GREEN MAKES NO OTHER WARRANTY RELATED TO THE EQUIPMENT OR ANY OTHER ITEM UNLESS IT DELIVERS TO YOU A SEPARATE WRITTEN WARRANTY.

**G. CONTACT** – To obtain a replacement warranty registration card or report a defect in any Equipment, to find the nearest Authorized Dealer or Authorized Service Center or report your dissatisfaction with their assistance, or to otherwise obtain information regarding this Warranty, please contact Steel Green.

Steel Green Manufacturing LLC  
Attn: Customer Service  
824 S State Road 39  
Lebanon, Indiana 46025  
(765) 481-2890  
sales@steelgreenmfg.com  
Steelgreenmfg.com



## WARRANTY REGISTRATION FORM

Fill out form completely and return to **Steel Green Manufacturing**  
**Email:** sales@steelgreenmfg.com  
**Mail:** 824 S State Road 39, Lebanon, IN 46052

## CONTACT INFORMATION

Company Name: \_\_\_\_\_  
Contact Name: \_\_\_\_\_  
Street: \_\_\_\_\_  
City: \_\_\_\_\_ State: \_\_\_\_\_ ZIP Code: \_\_\_\_\_  
Phone: \_\_\_\_\_ Email: \_\_\_\_\_

## MACHINE INFORMATION

Serial Number: \_\_\_\_\_ Date of Purchase: \_\_\_\_\_  
Dealer Name: \_\_\_\_\_  
Street: \_\_\_\_\_  
City: \_\_\_\_\_ State: \_\_\_\_\_ ZIP Code: \_\_\_\_\_  
Phone: \_\_\_\_\_ Salesperson: \_\_\_\_\_



steelgreenmfg.com (765) 481-2890    @SteelGreenMFG

