

# STEELGREEN<sup>TM</sup>

## MANUFACTURING

### INSTRUCTION MANUAL

#### HILL SIDE ASSIST ATTACHMENT

**Models:** SG36, SG42, SG46, & SG52

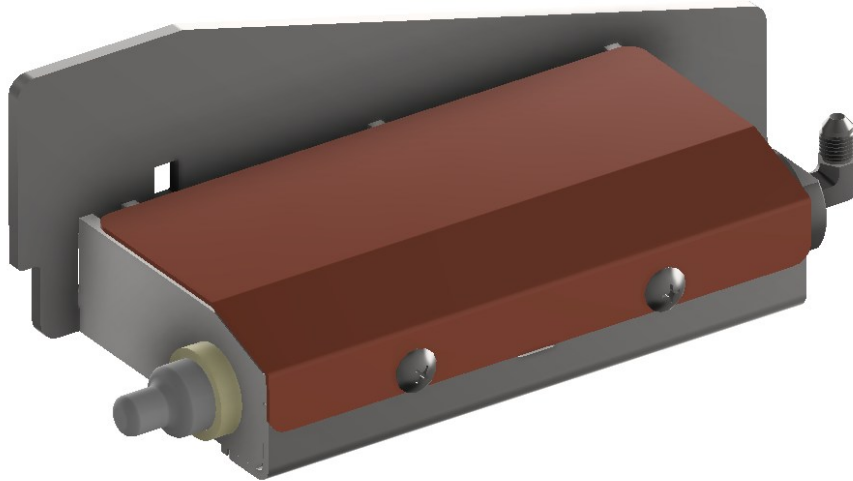

# HILL SIDE ASSIST INSTALLATION

**STEP 1:** Disconnect the battery, *ground* first and then *power* wire.



GROUND

POWER

## NOTICE

- *If your machine was built after November 2023, Skip to step 4.*
- *Repeat steps 2&3 for the other side.*

**STEP 2:**

- Remove the bolt and front tire.

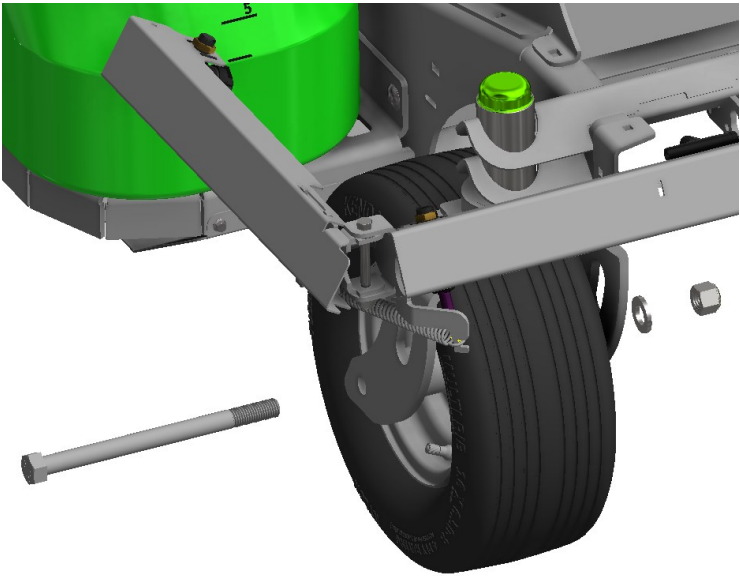

# HILL SIDE ASSIST INSTALLATION

- Remove the dust cover.

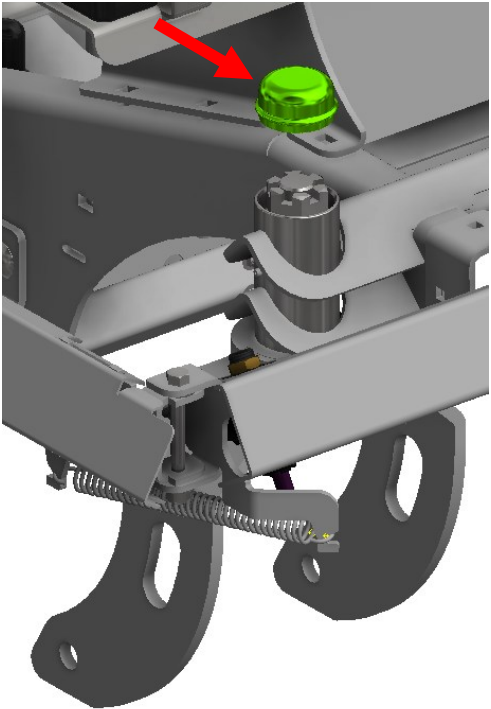

- Remove the cotter pin and nut which will release the yoke through the bottom.

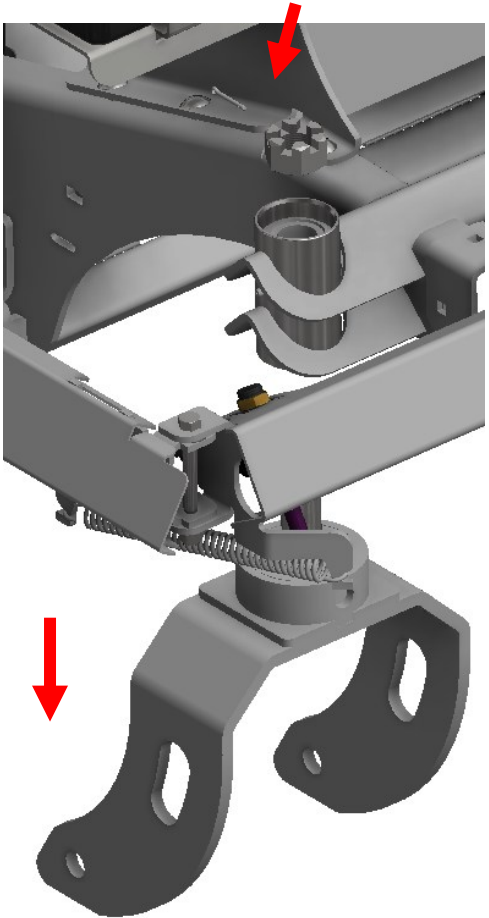

# HILL SIDE ASSIST INSTALLATION

**STEP 3:**

- Install the yokes W22-144 provided with the kit.
- Secure the yoke with the nut and carter pin.

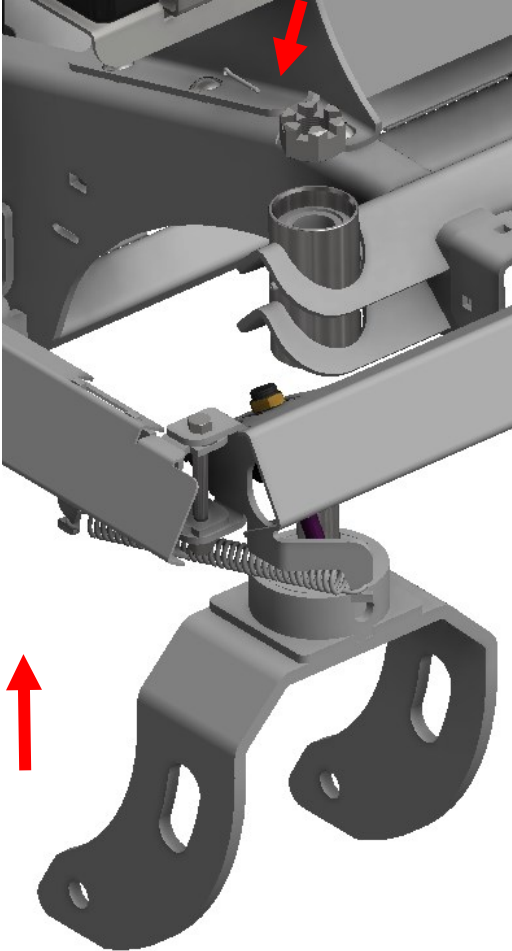

- Re-install the dust cover.

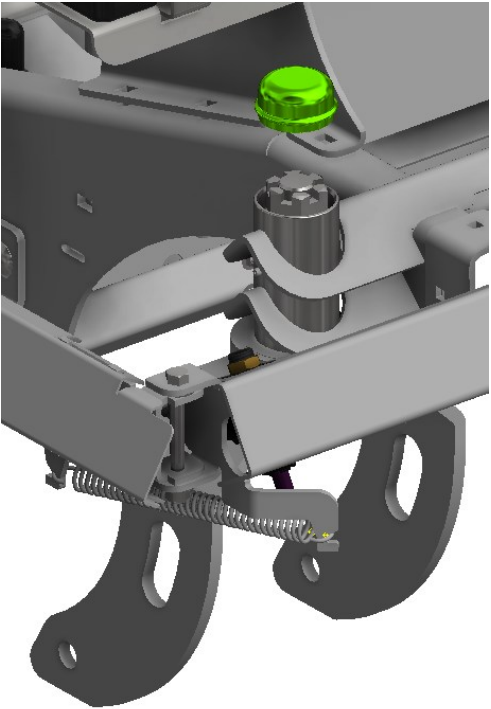

## HILL SIDE ASSIST INSTALLATION

- Re-install the front tire.

### NOTICE

*Regrease the bearings and housing.*

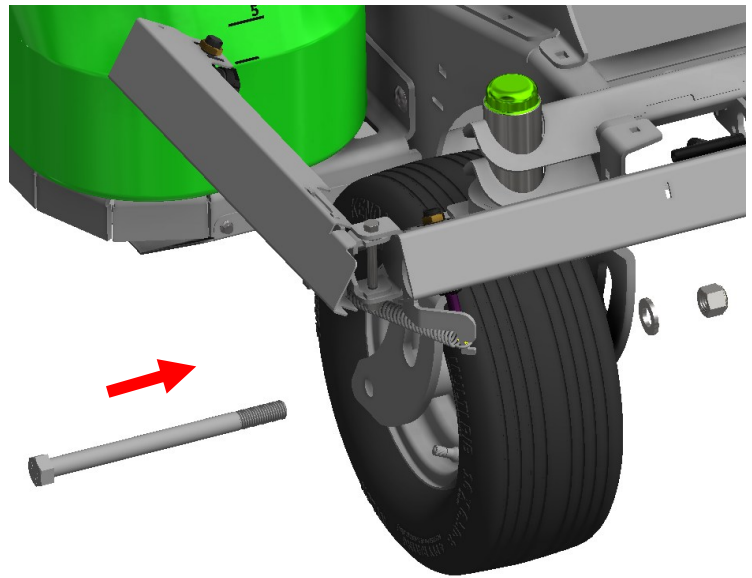

**STEP 4:** Use the 5/16 x 1 carriage bolts and 3/8 nuts provided with the kit and attach the cylinder assemblies to the side of the chassis.

### NOTICE

*If your machine is older than mid October 2021: You will need to either*

- *Drill mounting holes in BOTH SIDES of the chassis using the dimensions in (Fig 1) or attach the cylinder assembly to the top of the chassis (STEPS 4&5) and use the bracket as a templet.*
- *Or weld the side of the cylinder assemblies to the chassis.*

*The cylinder assembly MUST be properly secured from the side or warranty could be void.*

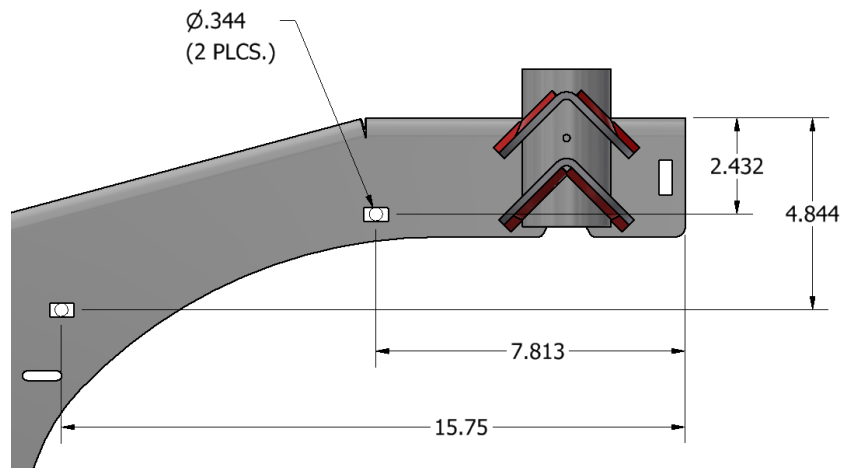

**Fig 1**

### NOTICE

*If you have a previous cylinder design, You will need to loosen the hopper and attach the cylinder under the hopper frame.*

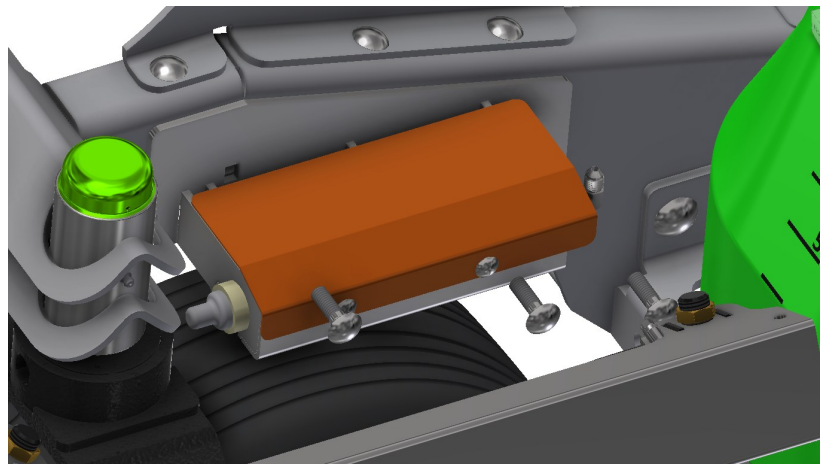

## HILL SIDE ASSIST INSTALLATION

**STEP 5:** Attach the solenoid valve assembly (provided with the kit) to the upright on the **RIGHT SIDE**. Using the 5/16 X 1 hex bolts, & nuts provided with the kit.

### NOTICE

- Some parts not shown for clarity.
- The orientation of the valve, ports 2 & 4 face forward.
- For SG36 models 2023 & older equipped with Flambeau fuel tank, remove the step bracket before installation.
- For current SG36 models 2024 & up equipped with dual pumps, attach the valve assembly to the back of the Flambeau fuel tank support. Fig. 1

PARTS LIST			
ITEM	QTY	PART NUMBER	TITLE
18	8	HFNC5-516S	HEX NUT, 5/16" SS
122	2	HFSSC-3131	HEX FLANGE BOLT, SS - 5/16 X 1

PARTS LIST			
ITEM	QTY	PART NUMBER	TITLE
1	2	CB-51634	CARRIAGE BOLT, SS - 5/16-18 x 3/4
2	2	HFNC5-516S	HEX FLANGE NUT, 5/16

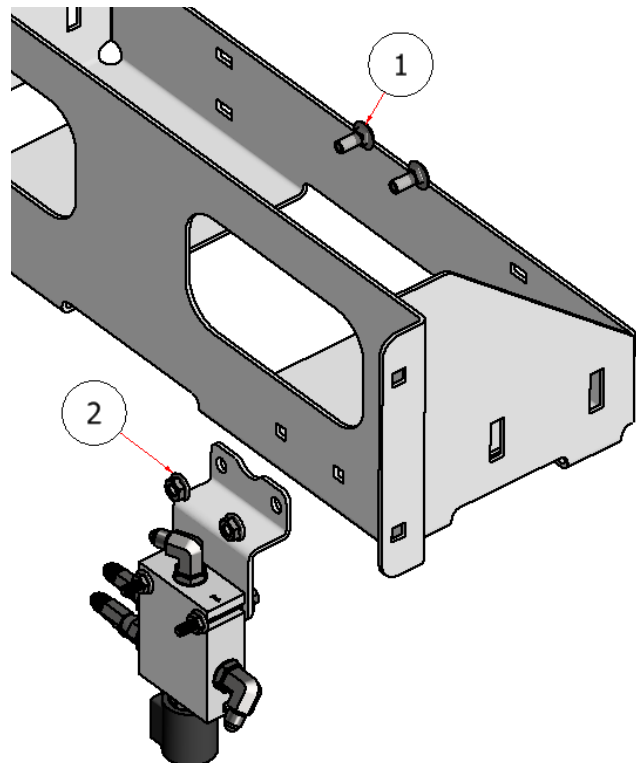
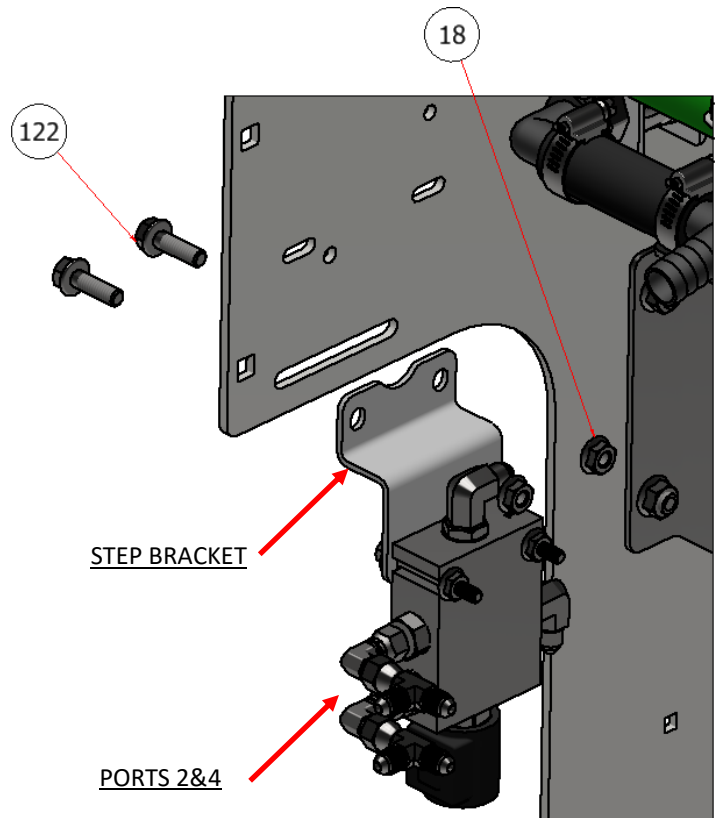
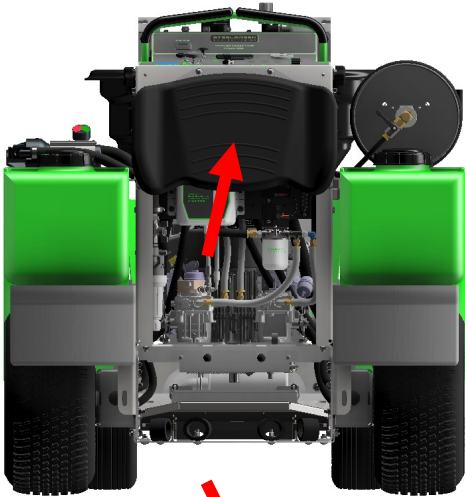

Fig. 1

# HILL SIDE ASSIST INSTALLATION

## STEP 6:

- Remove the knee pad to access the hydraulic oil reservoir.



- Loosen and remove the cap from the hydraulic oil reservoir.

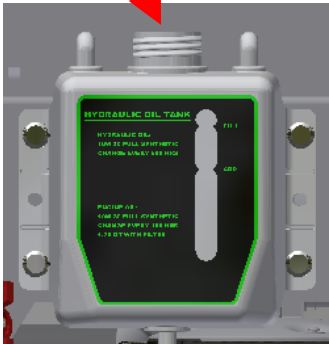

- Disconnect the rear hoses from the hydraulic pumps, place the hoses over a proper container draining the hydraulic oil.
- Once the oil has been drained, reconnect the hoses to the pumps.

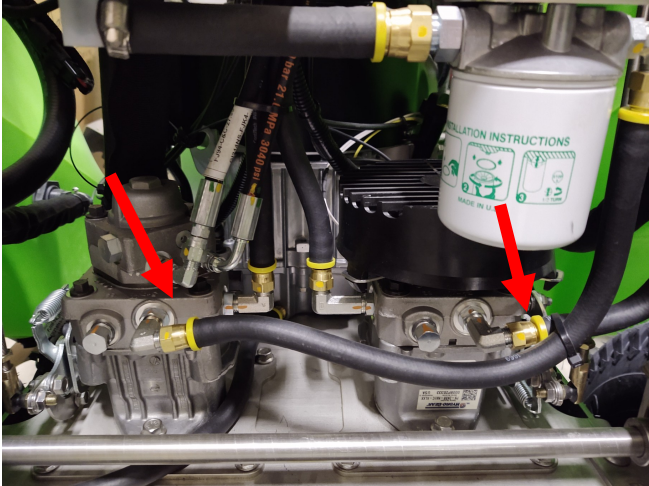

# HILL SIDE ASSIST INSTALLATION

**STEP 7:**

- Disconnect the return hose and fitting from the pump.

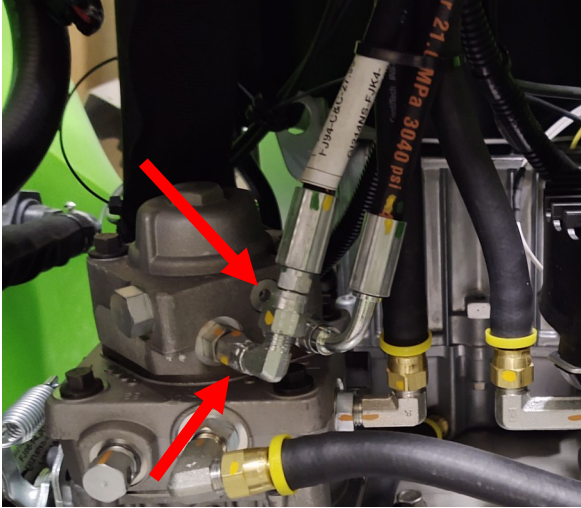

- Connect 1 H84031 “swivel tee fitting” (provided with the kit) to the return port.
- Reconnect the “swivel elbow fitting to the end of the “swivel tee fitting”.

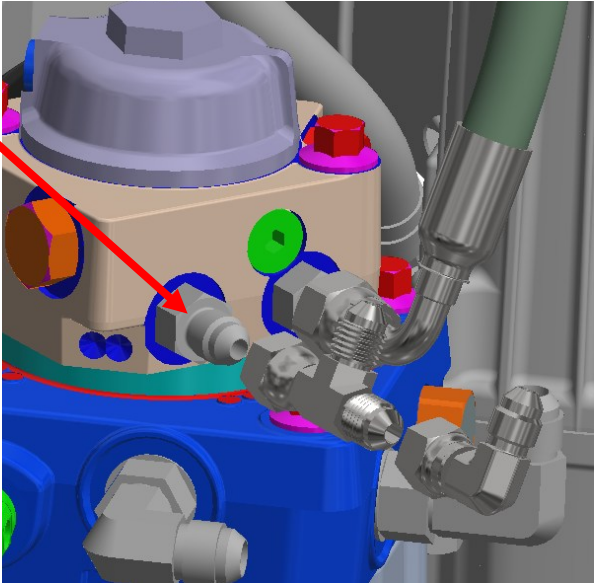

- Reconnect the return hose to “swivel tee fitting”.

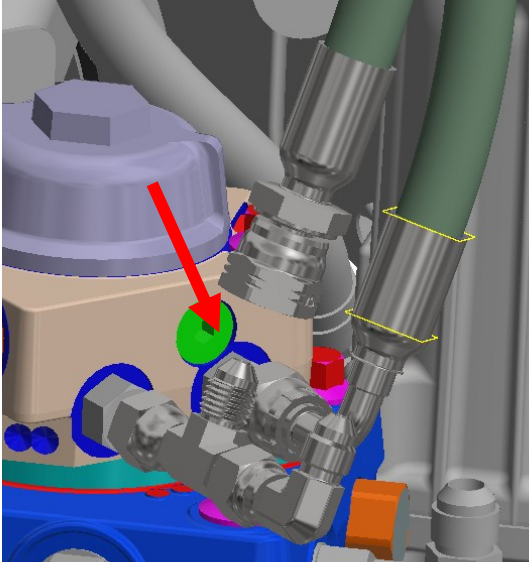

## HILL SIDE ASSIST INSTALLATION

### STEP 8:

- Disconnect the supply hose.

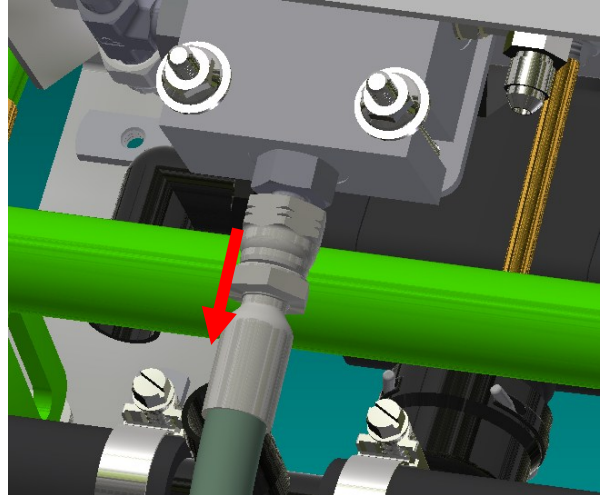

- Connect 1 (H84031) "swivel tee fitting", (provided with the kit) to the control valve .
- Reconnect the supply hose.

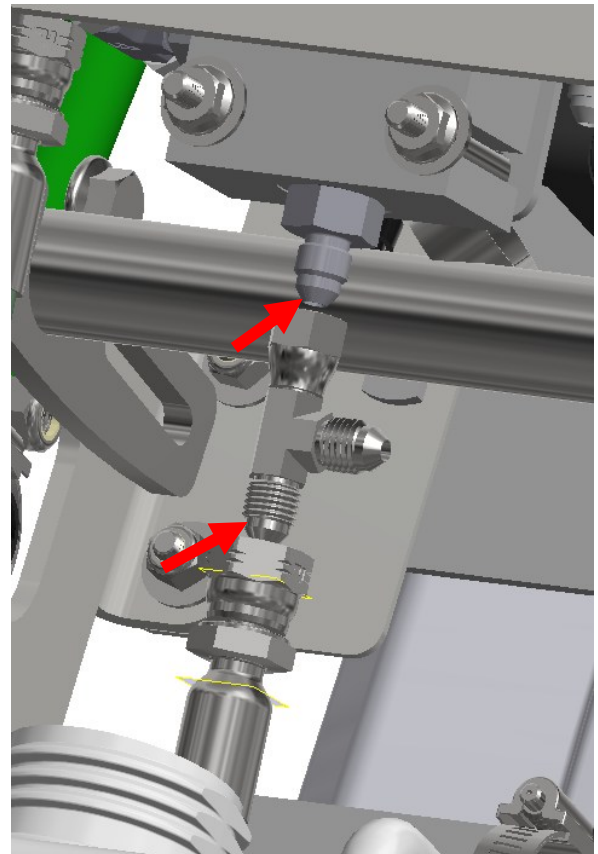

# HILL SIDE ASSIST INSTALLATION

## HOSE ROUTING

### STEP 9:

- Connect one end of hose with “orange wrap” to the elbow fitting on the hydro pump.

**ORANGE**

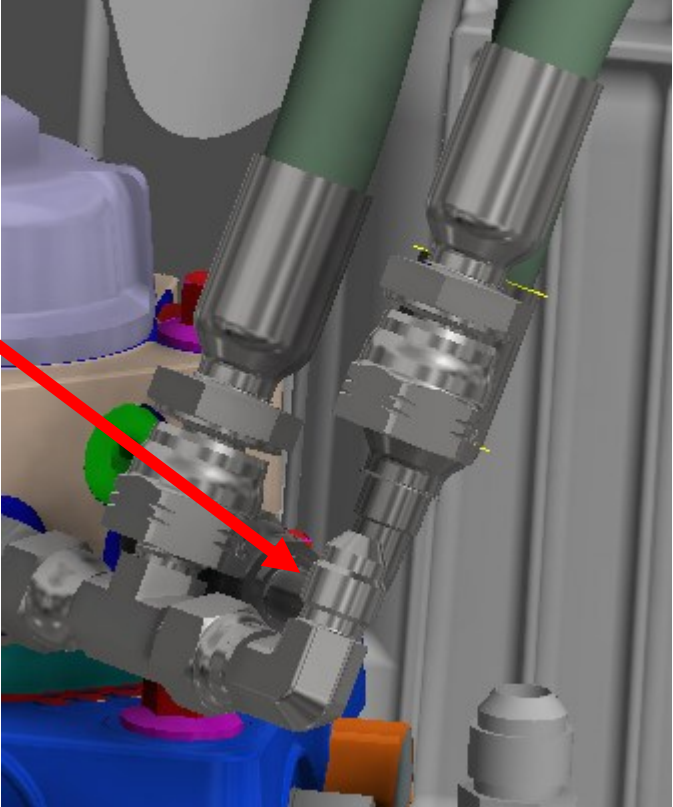

- Connect the other end of hose with “orange wrap” to port 3 of the solenoid valve.

**ORANGE**

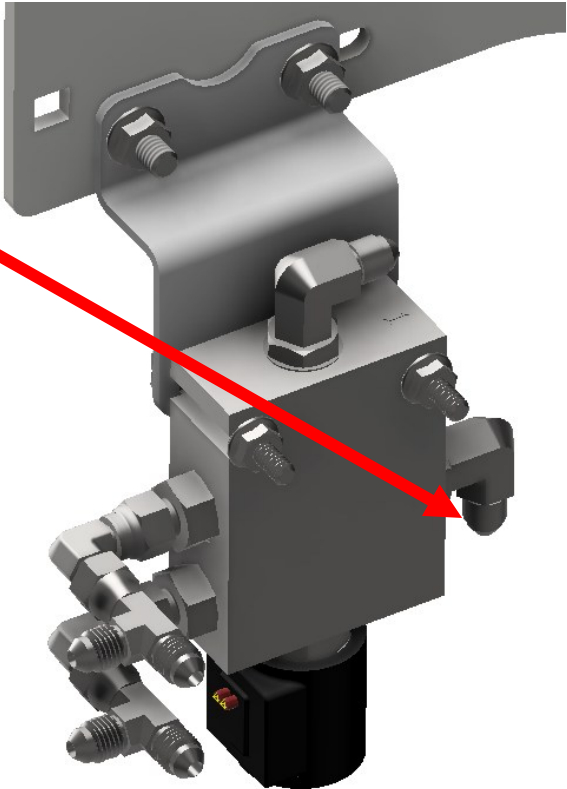
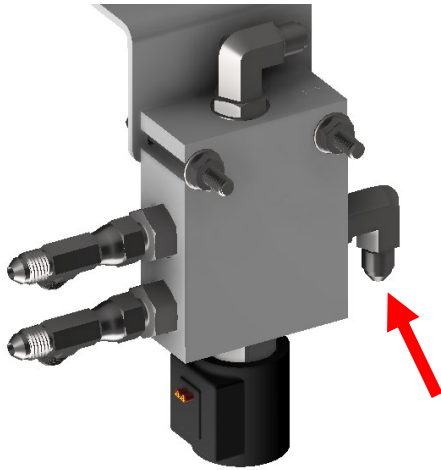

SG36 DUAL PUMP 2024 & UP

# HILL SIDE ASSIST INSTALLATION

- Connect one end of hose with “red wrap” to the swivel tee fitting on the hydraulic control valve.

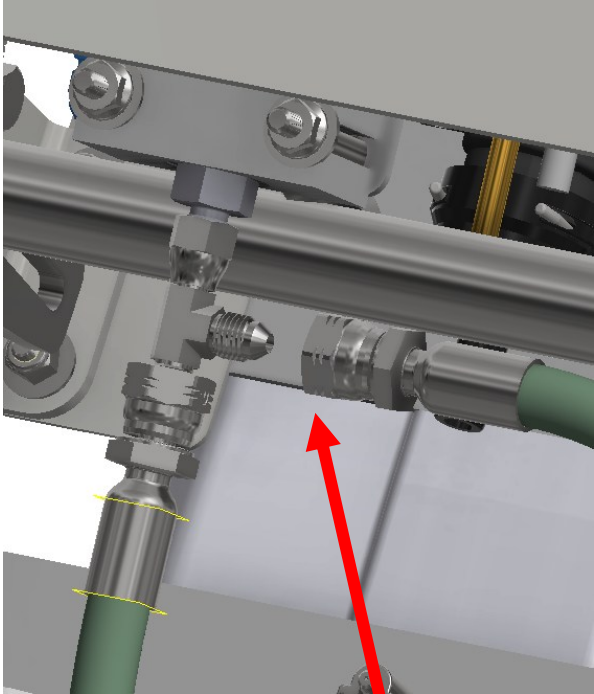

**RED**

- Connect the other end of hose with “red wrap” to port “1” on the solenoid valve.

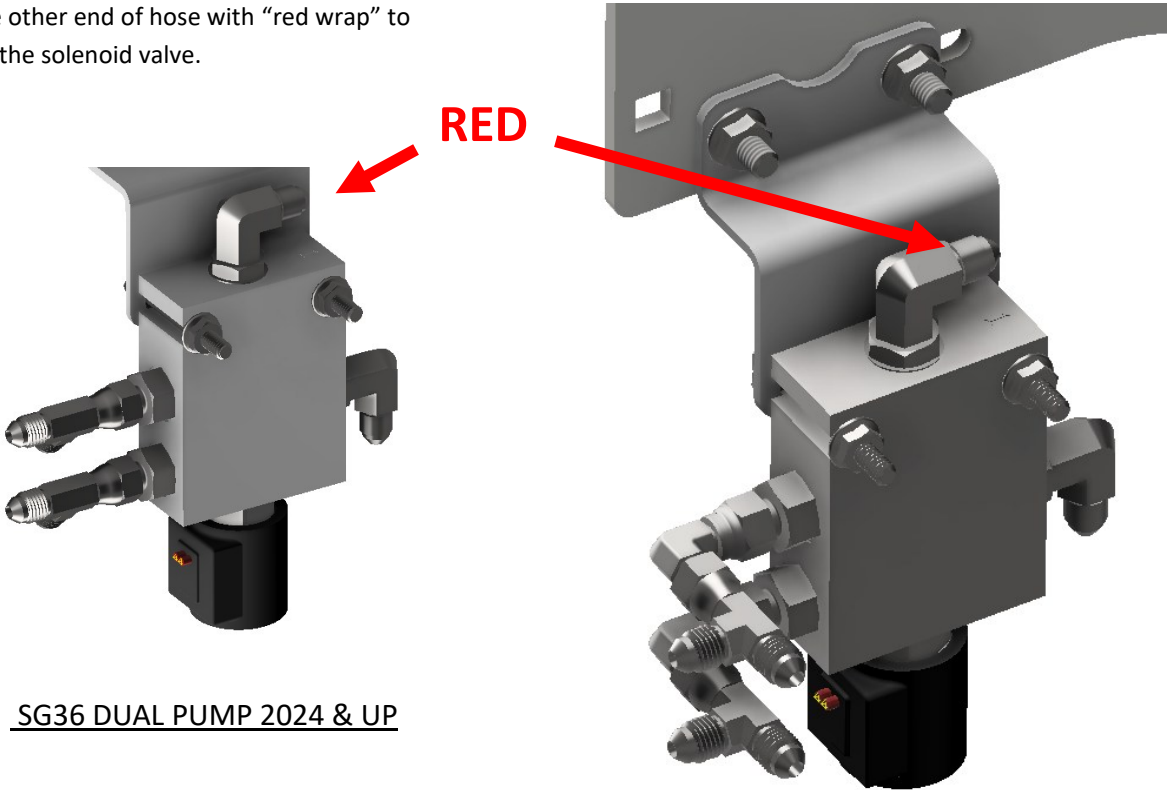

SG36 DUAL PUMP 2024 & UP

# HILL SIDE ASSIST INSTALLATION

- Connect the elbow end of hose with “blue wrap” to port 2 on the solenoid valve.

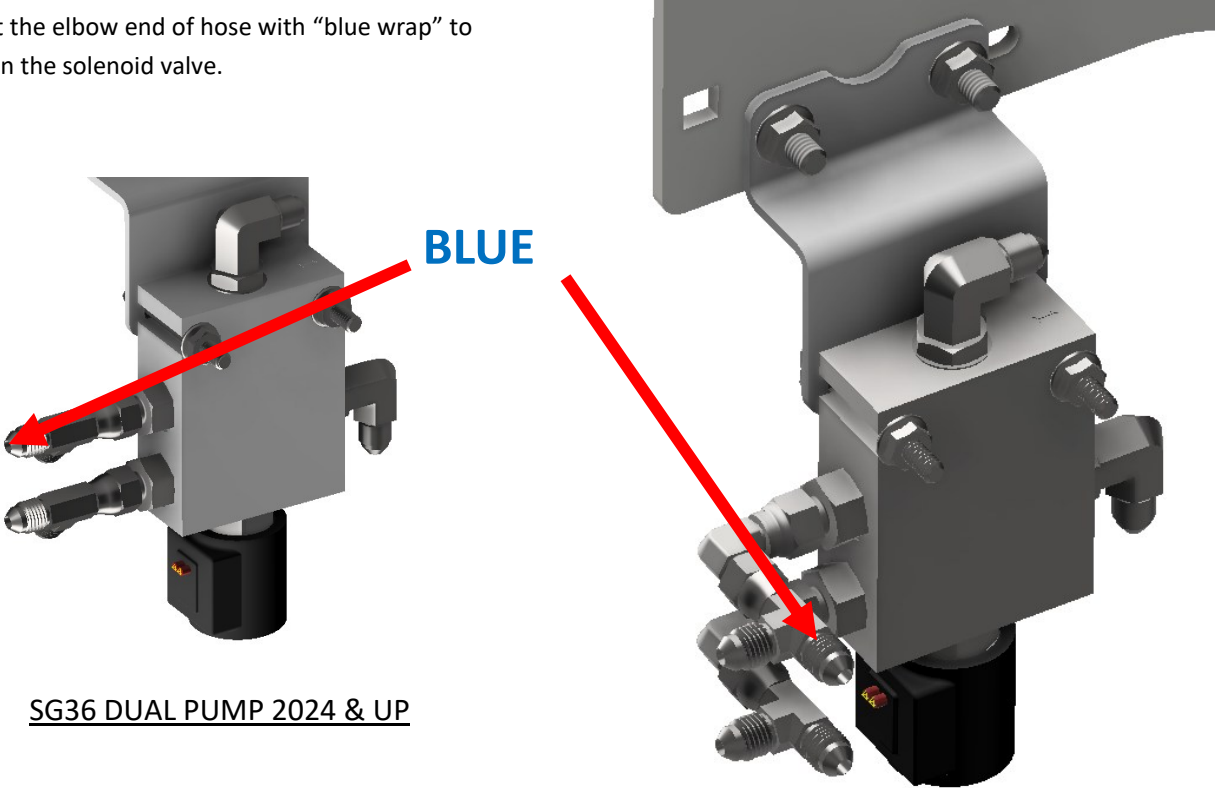

- Connect the straight end of hose with “blue wrap” to the elbow fitting on the end of the cylinder (RIGHT SIDE OF THE MACHINE).

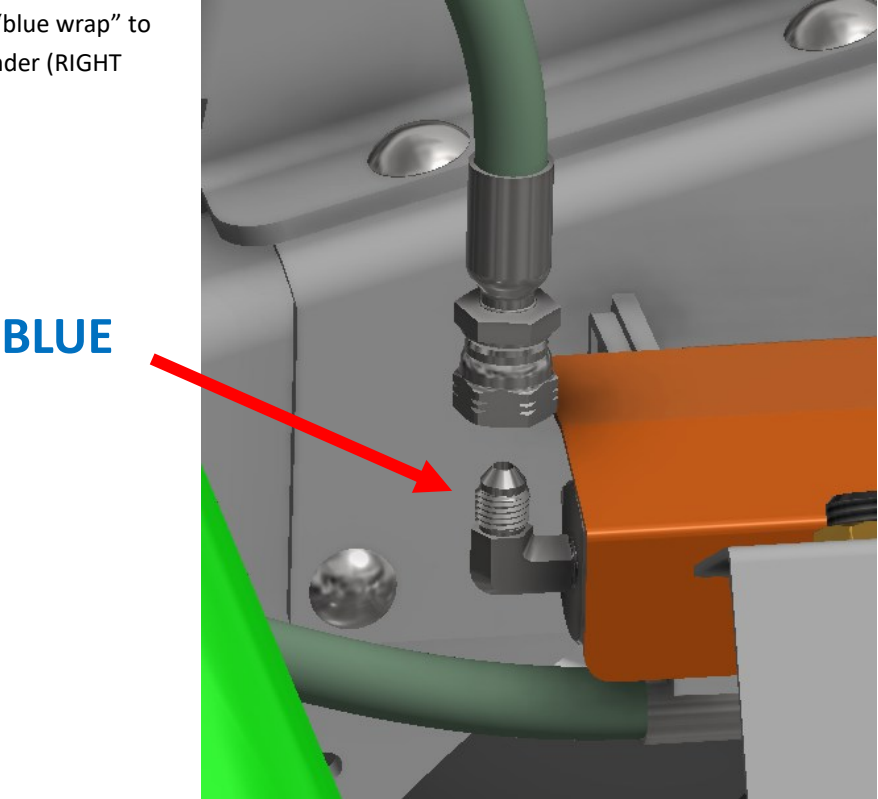

# HILL SIDE ASSIST INSTALLATION

- Connect the elbow end of hose with “green wrap” to port 4 on the solenoid valve.

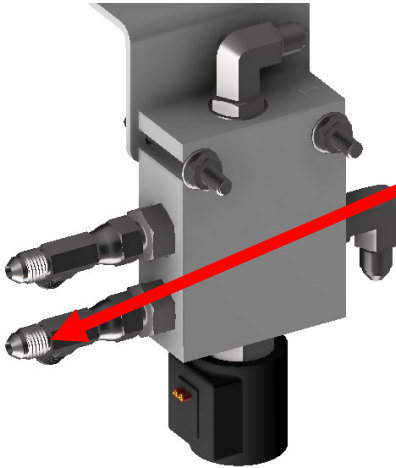

SG36 DUAL PUMP 2024 & UP

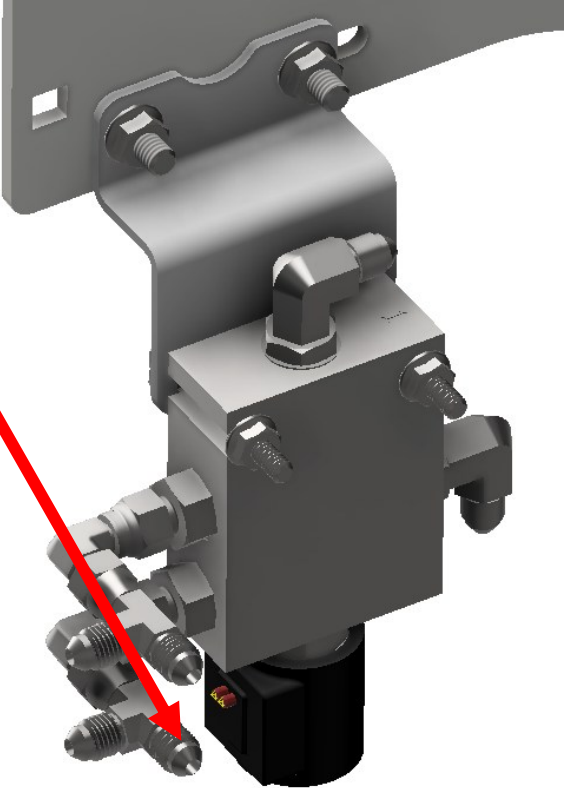

- Connect the straight end of hose with “green wrap” to the elbow fitting on the bottom of the cylinder (RIGHT SIDE OF THE MACHINE).

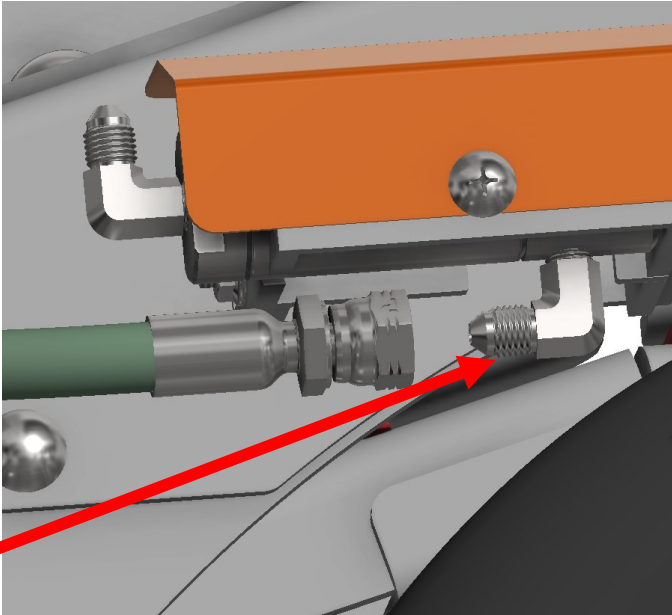

**GREEN**

# HILL SIDE ASSIST INSTALLATION

- Connect the end of hose with “black wrap” to the swivel tee fitting (PORT 4).

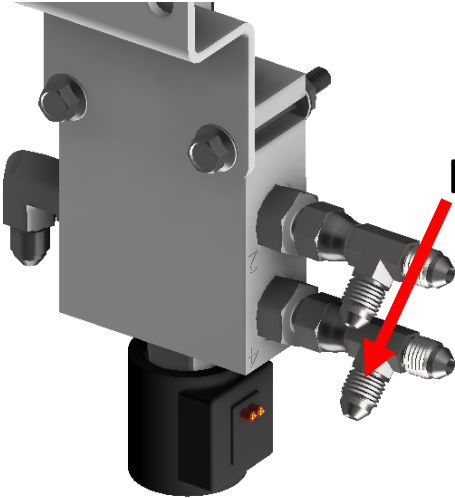

SG36 DUAL PUMP 2024 & UP

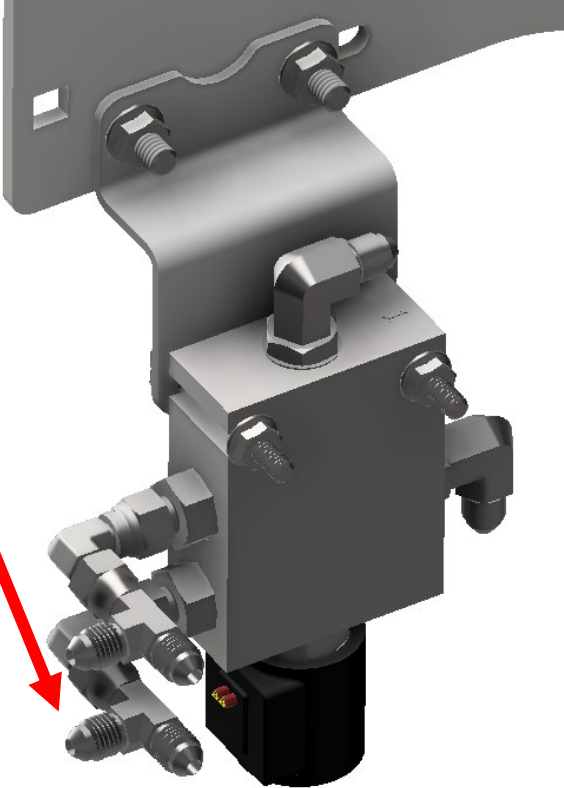

- Route the hose behind and around the engine and connect the other end of hose with “black wrap” to the elbow fitting on the bottom of the cylinder (LEFT SIDE OF THE MACHINE).

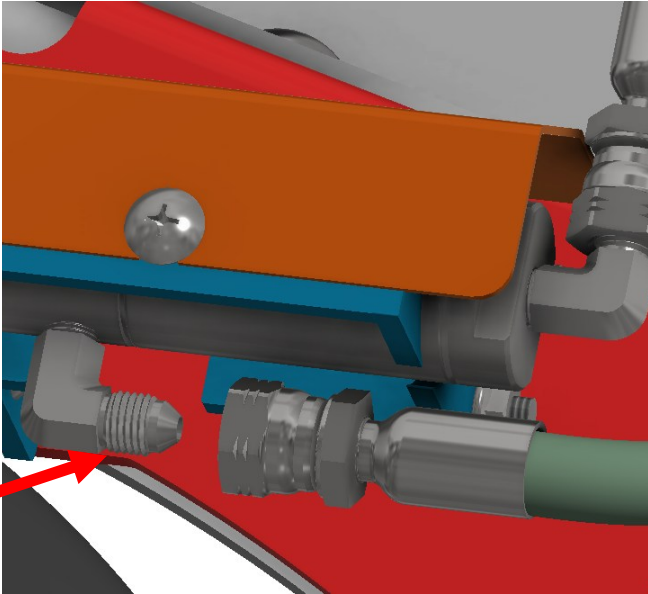

# HILL SIDE ASSIST INSTALLATION

- Connect one end of hose with “white wrap” to the swivel tee fitting (PORT 2).

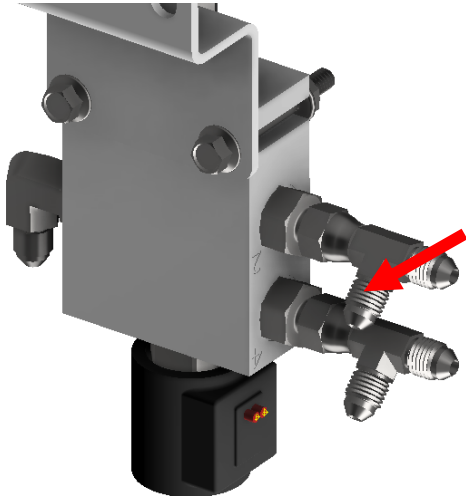

**WHITE**

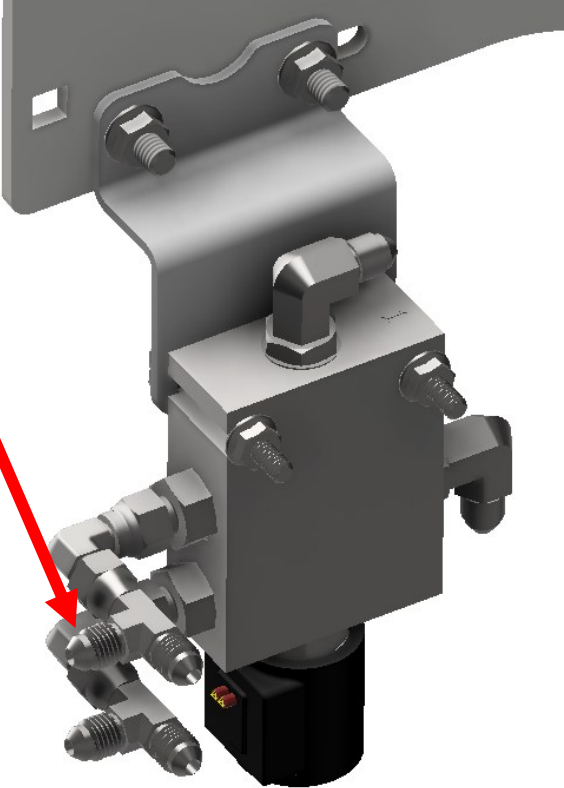

SG36 DUAL PUMP 2024 & UP

- Route the hose behind and around the engine and connect the other end of hose with “white wrap” to the elbow fitting on the end of the cylinder (LEFT SIDE OF THE MACHINE).

**WHITE**

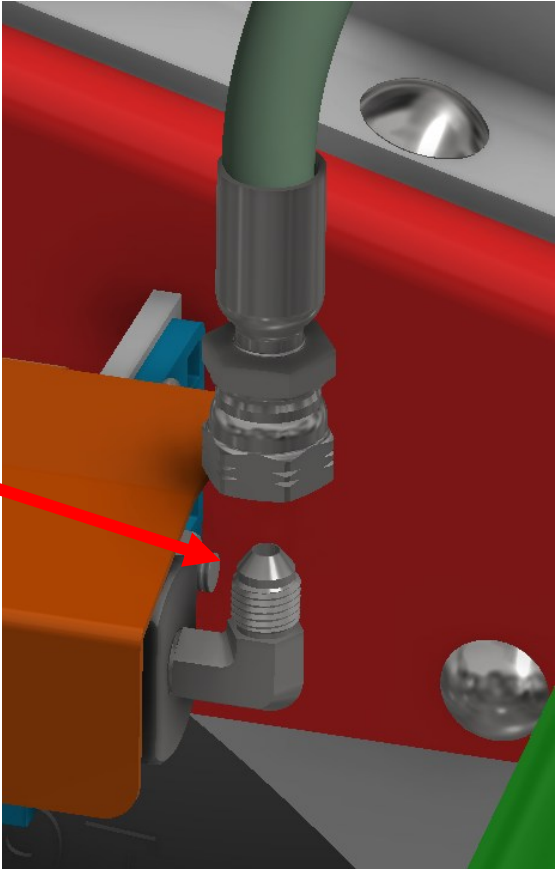

# HILL SIDE ASSIST INSTALLATION

## HSA ATTACHMENT HARNESS

PART NO. - SG-HSA-2

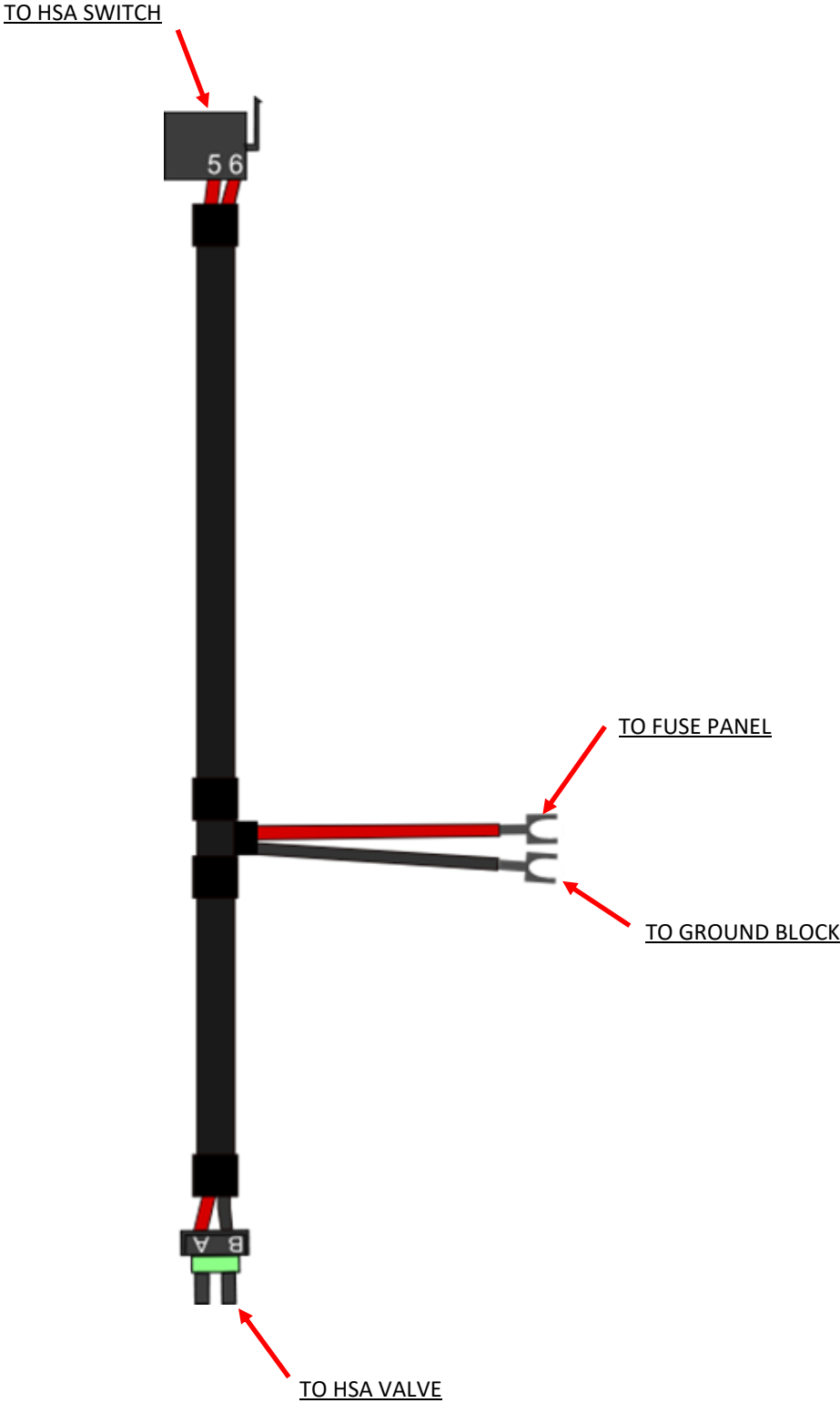

## HILL SIDE ASSIST INSTALLATION

### ELECTRICAL

#### STEP 10:

- Using a utility or exacto knife, cut out the right side switch opening on top of the dash.
- Attach the rocker switch in the opening with the long side of the switch facing down.
- Connect the end of the wire harness to the bottom of the rocker switch.

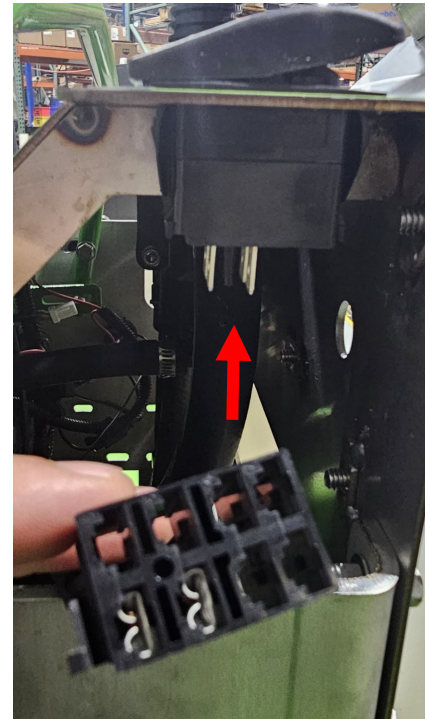
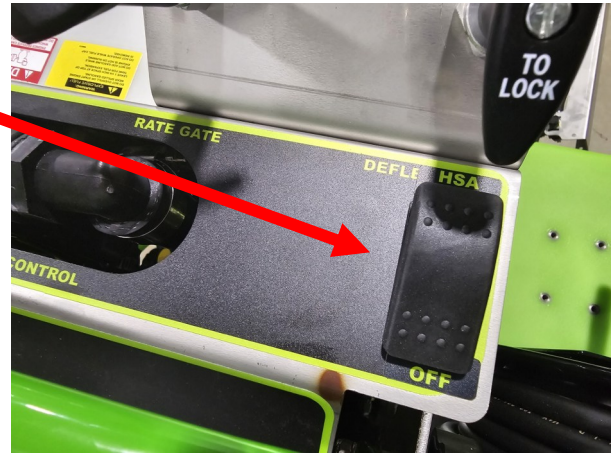

## HILL SIDE ASSIST INSTALLATION

### STEP 11:

- Connect the power wire from the harness to port 5 on the fuse block.
- Connect the ground wire from the harness to the ground block.
- Attach the proper fuse according to the chart Fig. 1.
- Attach the clear cover to the fuse block.

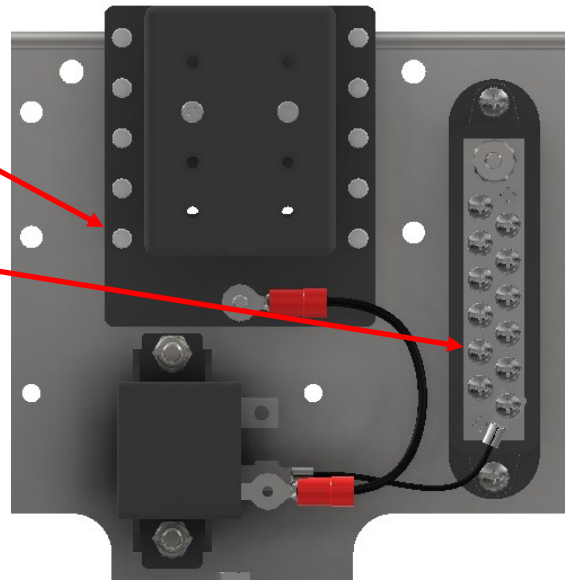

PORT	SG SERIES FUSE BLOCK		PORT
1	SPRAY PUMP 1 25 AMP		6
2	SPRAY PUMP 2 25 AMP		7
3	7 GAL. LEFT 25 AMP		8
4	7 GAL. RIGHT 25 AMP		9
5	HSA 10 AMP		10
		USB PORT 5 AMP	
		SPRAY PUMP SWITCH 25 AMP	
		SPEEDOMETER 1 AMP	
		FOAM MARKER 25 AMP	
		HEADLIGHT 10 AMP	

Fig. 1

- Connect the plug from wire harness to the plug on the hsa valve.

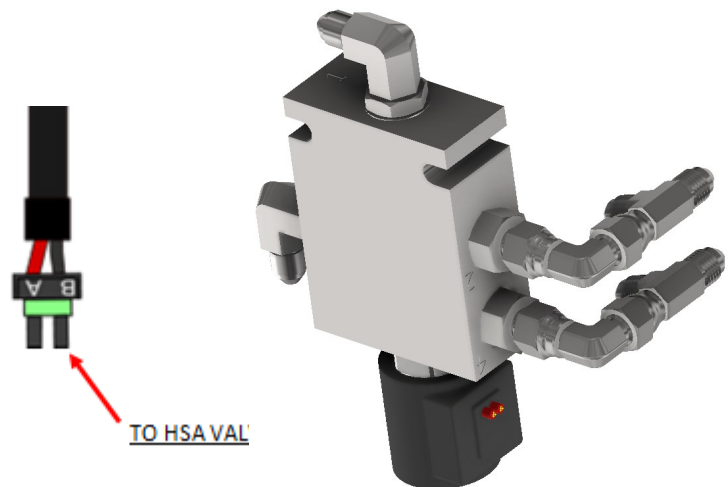

## HILL SIDE ASSIST INSTALLATION

**STEP 12:** Reconnect the battery, *ground* first and then *power* wire.

**NOTE:** Check that all hose connections are tight.

### STEP 13:

- Refill the hydraulic oil to the proper level.
- Start the machine and activate the hill side assist a couple times or until the oil is through the system and the cylinders are functioning.
- Turn the machine off and refill the oil to the proper level.

### STEP 14:

- Loosen the adjustment nut (11/16") on both cylinders. *Fig. 1*
- The cylinder is to be set at 1/2" inch from the end of the plunger to the edge of the yoke. *Fig. 2*

**TIP** Turn the tire so the hole is facing away from the cylinder shaft and use a 1/2" rod or bolt between the yoke and cylinder shaft.



GROUND

POWER

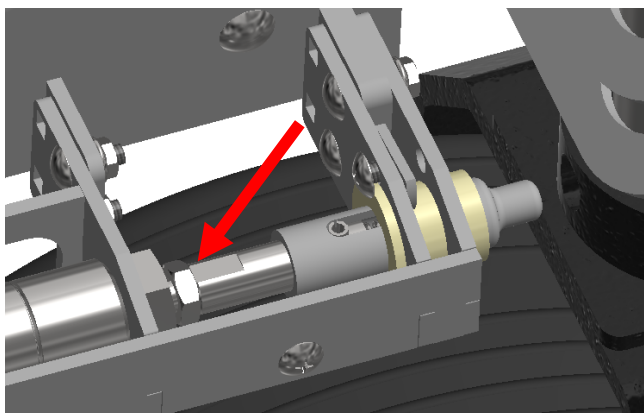
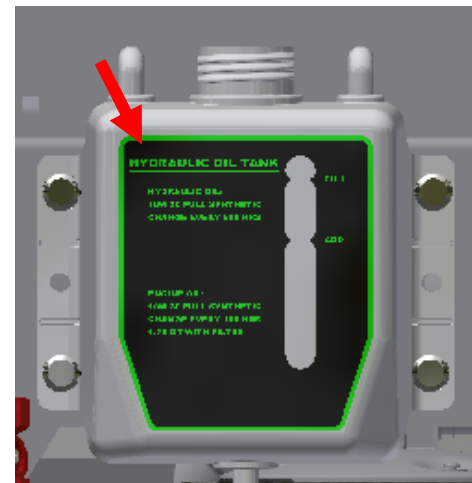

*Fig. 1*

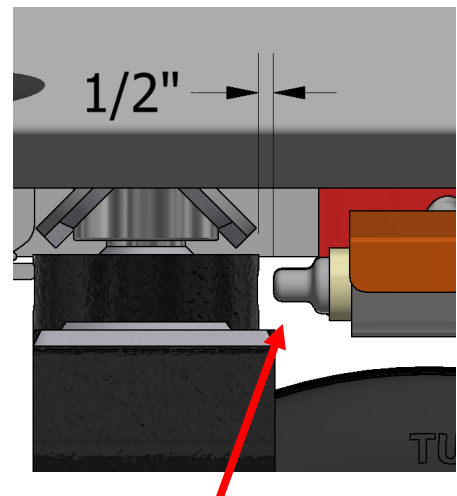

*Fig. 2*



MADE IN THE USA

Steel Green Mfg.  
 824 S State Road 39  
 Lebanon, IN 46052  
[Steelgreenmfg.com](http://Steelgreenmfg.com)  
 (765)-481-2890

MANUAL PART NO.	MANUAL REV.	DESCRIPTION	KIT PART NO.
SGM-023	9	SG HILL SIDE ASSIST	A10040 A10040-36