

# STEELGREEN MANUFACTURING™



**SGLITE**

**SPREADER/SPRAYER**

**OPERATOR & SERVICE MANUAL**



For additional information, please visit us at [www.steelgreenmfg.com](http://www.steelgreenmfg.com)



# TABLE OF CONTENTS

GENERAL INFORMATION .....	3
SPECIFICATIONS .....	4
SAFE OPERATION .....	5
CONTROLS AND OPERATION .....	6
DASH PANEL .....	6
STRIKER SET-UP .....	7
OPERATION .....	8
SPREADER .....	10
SPREADER CALIBRATION CHART .....	11
HOPPER DRAIN INSTRUCTIONS .....	12
SPRAY SYSTEM .....	12
STANDARD VOLUME SPRAY CHART .....	15
CARE & MAINTENANCE .....	16
DRAWINGS & DIAGRAMS .....	22
NOTES .....	24
WARRANTY .....	25



# GENERAL INFORMATION

Thank you for purchasing a Steel Green machine! Please read and understand this manual before operating this piece of equipment. This manual will assist you in areas of operation, safety, and maintenance. Any unresolved question can be directed to Steel Green Mfg. We at Steel Green are excited to hear feedback from our customer base so we can continue to provide you with the most productive and efficient equipment possible

## NOTICE

*This manual and all information and illustrations were accurate at the time of publication. Steel Green Mfg. reserves the right to make changes without notice.*

**IMPORTANT: READ SAFETY RULES AND INSTRUCTIONS CAREFULLY.**

## WARNING

*Steel Green units are equipped with an internal combustion engine and should not be used on or near any unimproved forest-covered, brush-covered or grass-covered land unless the engine's exhaust system is equipped with a spark arrester meeting applicable local or state laws (if any). If a spark arrester is used, it should be maintained in effective working order by the operator. In the State of California, the above is required by law (Section 4442 of the California Public Resources Code). Other states may have similar laws. Federal laws apply on federal lands. A spark arrester for the muffler is available through your nearest engine authorized service dealer or contact the service department .*

Serial Number: \_\_\_\_\_

Date Purchased: \_\_\_\_\_

Dealer Name: \_\_\_\_\_

Dealer Phone Number: \_\_\_\_\_

SPECIFICATIONS

DIMENSIONS:

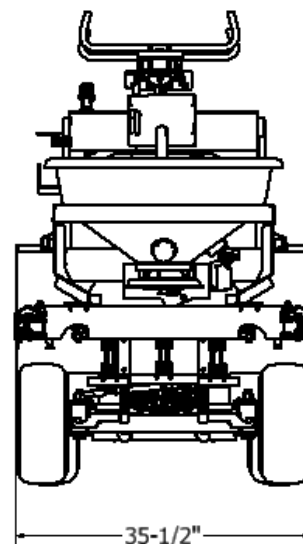
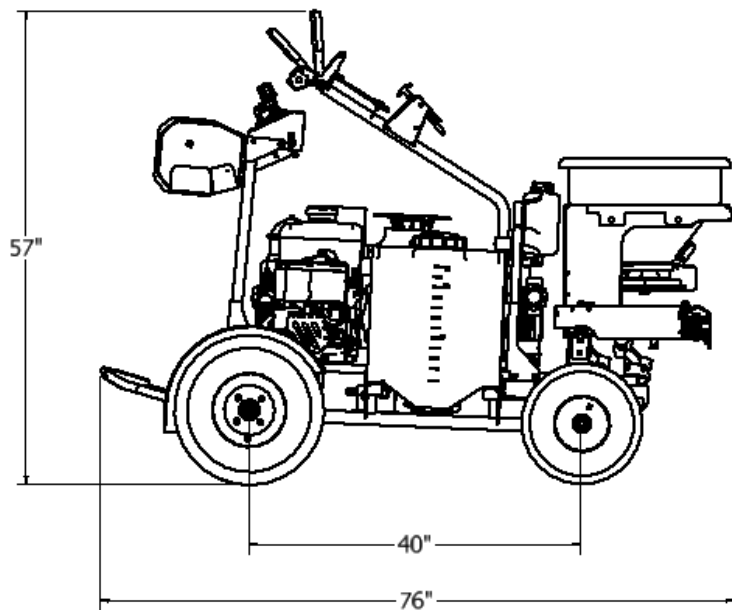
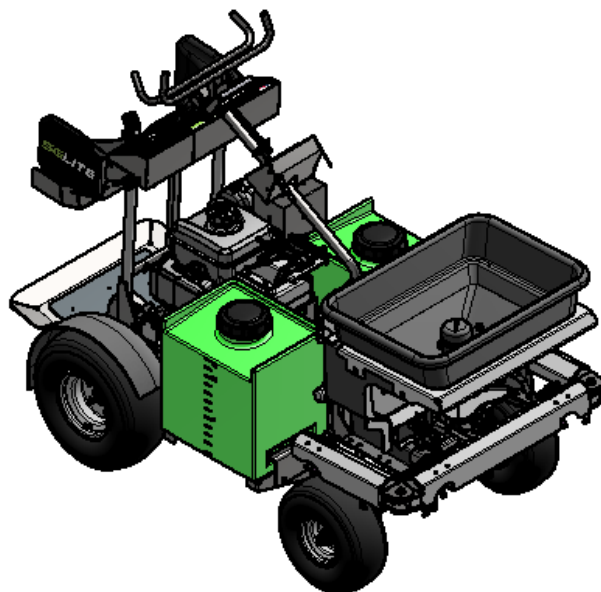

DESCRIPTION	<b>SGLITE</b>
WEIGHT	600 LBS.
FRONT TIRE	15 X 6-6
REAR TIRE	18 X 7.50-8
SPRAY CAPACITY	24 GAL.
SPRAY WIDTH	Up to 8'
HOPPER CAPACITY	150 lbs.
VARIABLE SPREAD WIDTH	Up to 25'
FUEL CAPACITY	1.58 GAL.
TRANSPORT SPEED	Up to 10 mph
RATE PRODUCTION	96,000 sq. ft. per fill based on 1/4 gal. spray nozzles.

## SAFE OPERATION

### CAUTION

*THE FOLLOWING IMPORTANT SAFETY INSTRUCTIONS WHICH, IF NOT FOLLOWED, COULD ENDANGER THE PERSONAL SAFETY AND/OR PROPERTY OF YOURSELF AND OTHERS. READ AND FOLLOW ALL INSTRUCTIONS IN THIS MANUAL BEFORE ATTEMPTING TO OPERATE YOUR UNIT. FAILURE TO COMPLY WITH THESE INSTRUCTIONS MAY RESULT IN PERSONAL INJURY.*

#### GENERAL OPERATION:

- Do not operate the machine while under the influence of alcohol or drugs.
- Only allow responsible adults, who have practiced driving a Steel Green machine and are familiar with the instructions to operate the machine. Local restrictions may restrict the age of the operator.

#### RE-FUELING:

- ALWAYS STOP THE ENGINE and allow it to cool before refueling. NEVER remove the gas cap to add fuel while the engine is running, and never fill the gas tank on an engine that has been running and is still hot – gas spilled on a hot engine can ignite.
- Never smoke while refueling.
- Do not overfill fuel tank.
- Follow warning label on fuel tank.

#### SLOPE OPERATION:

- Cease operation if stability is questionable, or if you are unsure of the ability to continue safely.
- Keep alert for hidden hazards on the terrain.
- Stay away from drop-offs, ditches and embankments.
- Never operate on slope angles greater than 10° with a Steel Green machine in its basic configuration. Basic configuration is defined as a Steel Green machine with a hopper & no attachments. (A 10° slope is a slope that rises 1 m (3.5 ft) over a horizontal distance of 6.1 m (20 ft).)
- When using attachments, never operate a Steel Green machine on slope angles greater than 10°. The addition of an extra tank, or other attachments. Attachments will increase the risk of a rollover. (A 10° slope is a slope that rises 1 m (3.5 ft) over a horizontal distance of 6.1 m (20 ft).)

CONTROLS & OPERATION

DASH PANEL

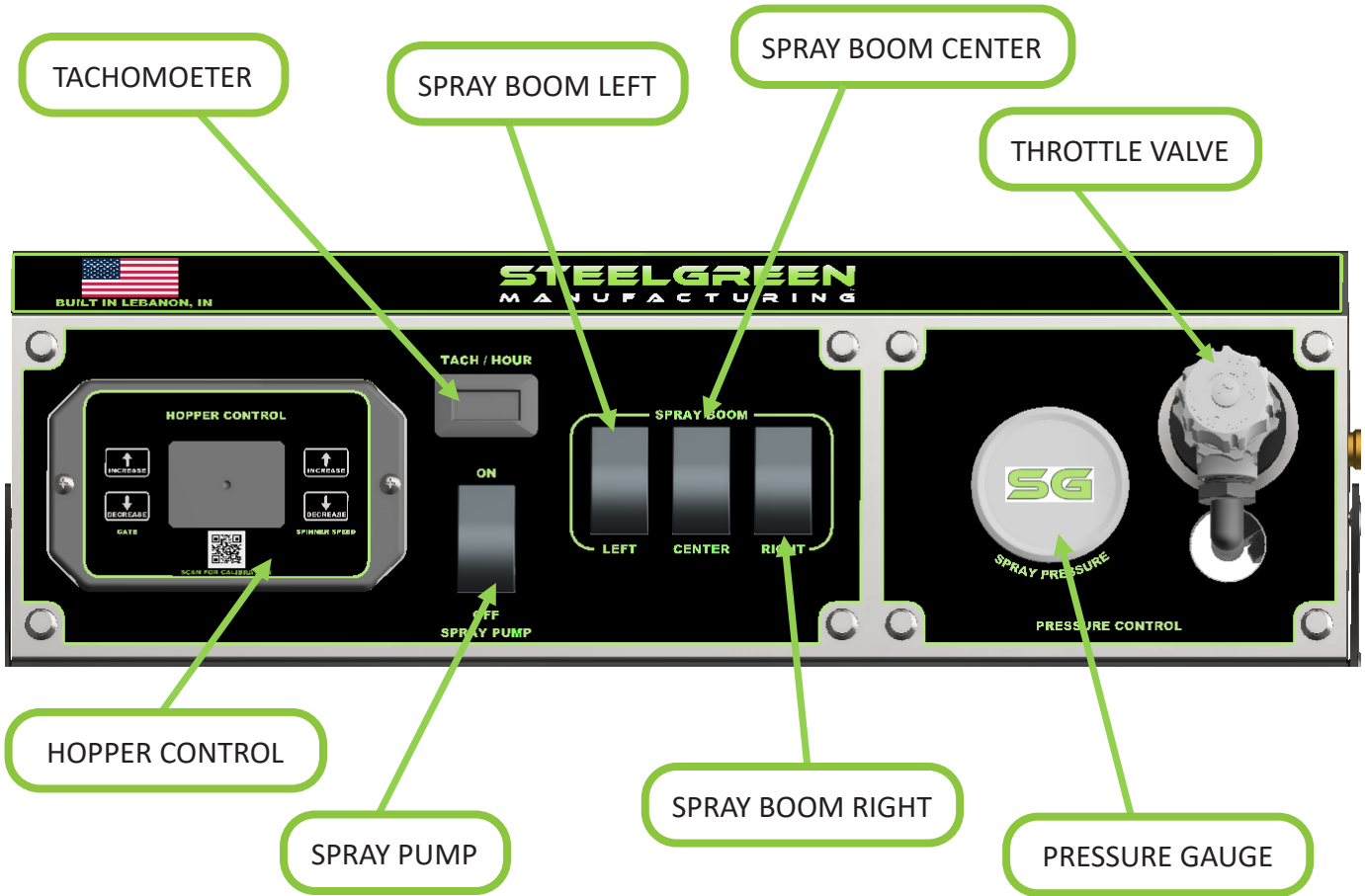

HANDLE BAR SWITCHES

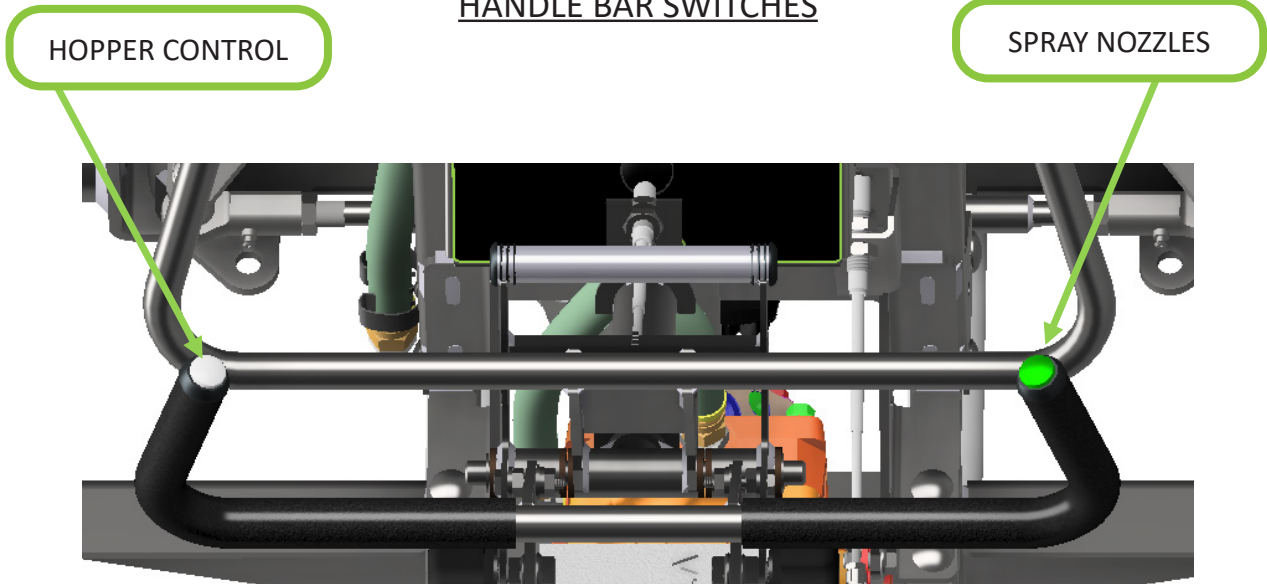

# CONTROLS & OPERATION

# DASH PANEL

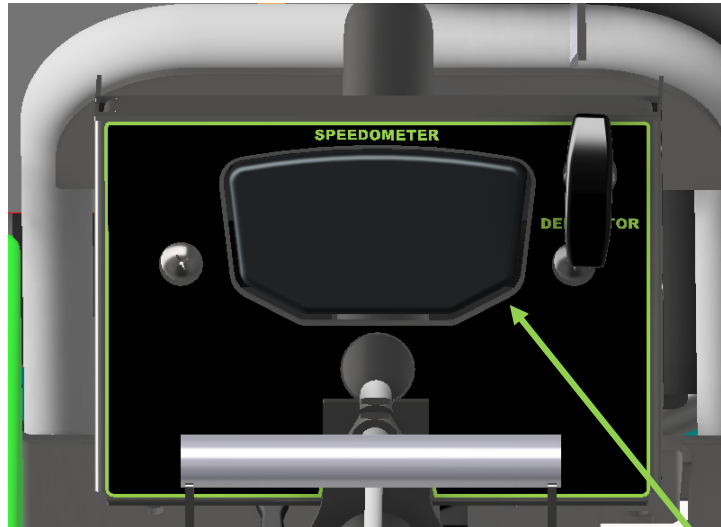

SPEEDOMETER



## Setup Mode

### Overview:

**Description:** Setup mode is crucial for Striker to operate correctly.

SETTINGS ORDER	VALUE	DEFAULT
A. Distance Units	KM/H or M/H	M/H
B. Tire Size	Millimeters	2109mm
C. Clock	12Hr or 24Hr	12Hr
	Time-of-Day	12:00:00
D. Temperature	°F or °C	°F
E. LED Alerts	Temperature High Alert	000°
	Temperature Danger Alert	000°
	Voltage Low Alert	0V
	Voltage Danger Alert	0V
F. Maintenance	Oil Countdown	0000 M/H
	Care Countdown	0000 M/H
G. AVG SPD	Screen 2 or 3	Screen 3
H. Distance	Resolution	Res 2

### Enter Setup Mode:

HOLD DOWN ALL THREE BUTTONS FOR 3 SECONDS.



All segments on the screen will turn black. Release to continue.

## Setup Mode

### Setup Distance Units:

Striker defaults to M/H.



TO CYCLE BETWEEN M/H AND KM/H, PRESS THE LEFT BUTTON.



TO CONFIRM, PRESS THE CENTER BUTTON. Striker will move on to the next setting.



### Setup Wheel Size:

See "Measure Wheel Size" on

SGLITE with 18 x 7.50-8 tire, Enter - 1435



MODIFY DIGIT: LEFT BUTTON

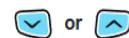

or



NEXT DIGIT: RIGHT BUTTON

TO CONFIRM, PRESS THE CENTER BUTTON.



Striker will move on to the next setting.

## NOTICE

Red & Amber blinking lights indicate battery voltage is below 12 volts.

## CONTROLS & OPERATION

### PARKING BRAKE OPERATION:

- Raise the lever to lower the foot board & disengage the parking brake.
- *To engage the parking brake, raise the foot board to the closed position.*

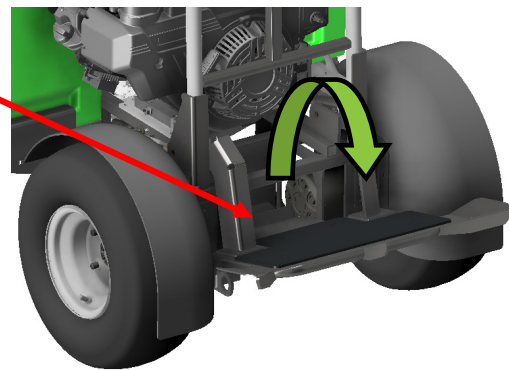
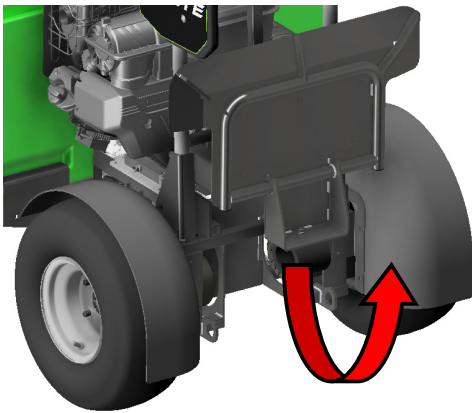
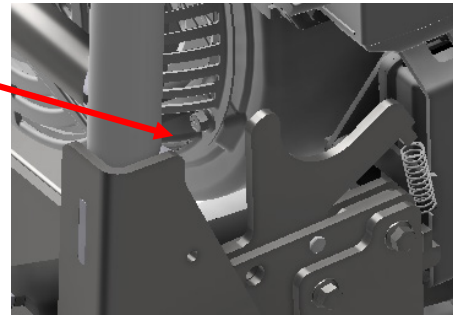

### MACHINE OPERATION:

- To drive the machine, step up on the foot board and rest against the chest pad.
- Turn the throttle knob about half throttle.
- Turn the key to start the machine.

### BRAKE DISENGAGED

CHEST PAD

FOOT BOARD

KEY

THROTTLE

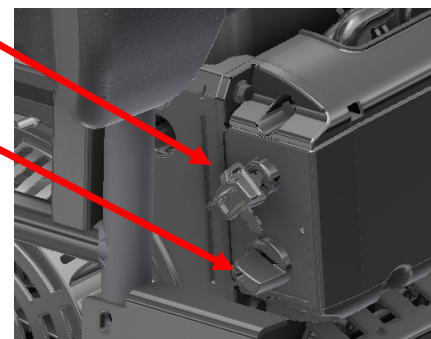
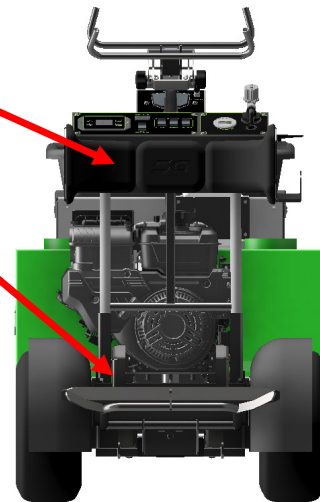

## CONTROLS & OPERATION

### HANDLE BARS:

- The short bar is reverse.
- The wide front bar is forward.

### DRIVING THE MACHINE:

- Squeeze the front bar against the center bar to drive forward.
- Squeeze the short bar back against the center bar to drive in reverse.
- To maneuver a left turn, turn the handle bar left.
- To maneuver a right turn, turn the handle bar right.

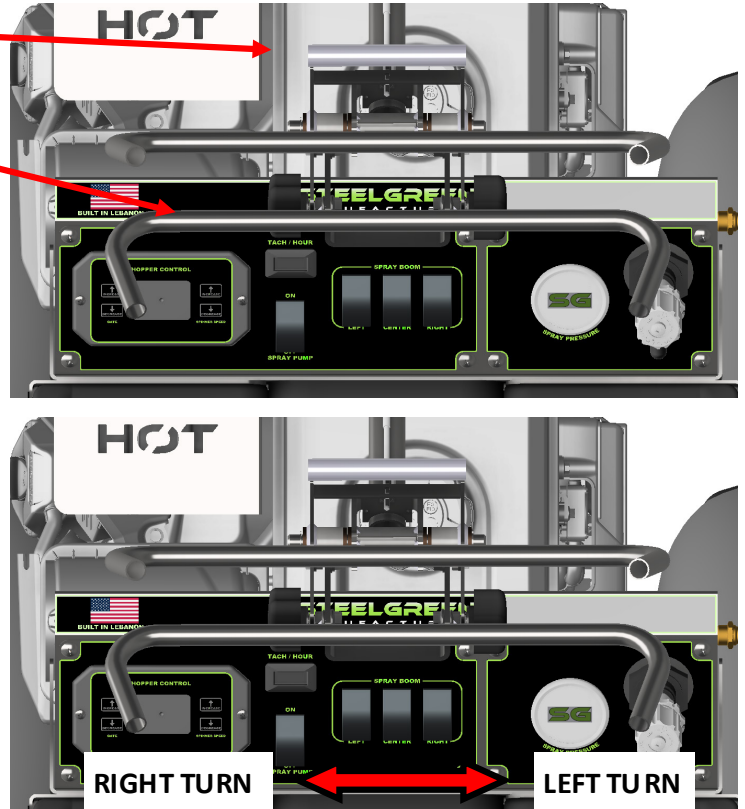

### SPEED ADJUSTMENT:

- Speed adjustment is used to set the maximum speed for spray applications.
- Adjust the speed by loosening the black knobs on both sides.
- Move the bar forward or back to set the desired max. speed and tighten the knobs.

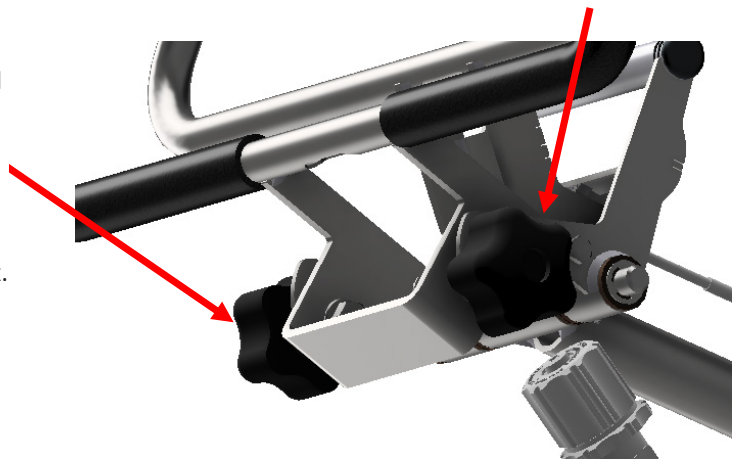

## CONTROLS & OPERATION

### SPREADER:

**⚠ CAUTION**

- To avoid injury to the hand, ensure the engine is turned OFF before adjusting.*
- Wear appropriate clothing & safety equipment when applying & handling chemicals.*

- Earthway balances the spread pattern by shifting the product placement on the spinner. Placing the product on the impeller close to the shaft or the center will cause the spread pattern to be heavier to the right as it rides the impeller for a longer period. If the product is placed on the outer edge of the impeller, the spread pattern will be heavier to the left as the spinner turns clockwise.
- Press the white thumb switch on the handle bar to power the hopper on (Fig. 3).
- Start with the gate all the way open (Fig. 1).
- The spinner speed is adjusted by pressing the increase or decrease buttons on the screen (Fig. 1).
- As you are spreading, you should be able to see the spread pattern in front of you. Generally, all spreaders will tend to throw fertilizer heavy to the right. As you continue to spread, slowly close the gate in small increments. This will bring the spread pattern dead center in front of you (Fig. 2).

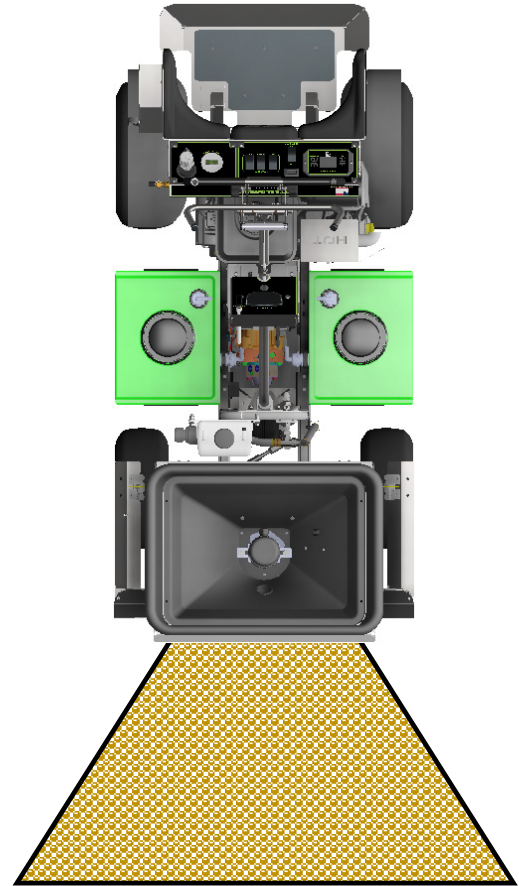

**THROW FERTILIZER  
TO CENTER OF TIRE TRACKS**

Fig. 2

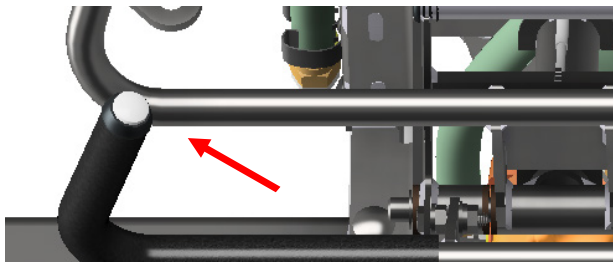

Fig. 3

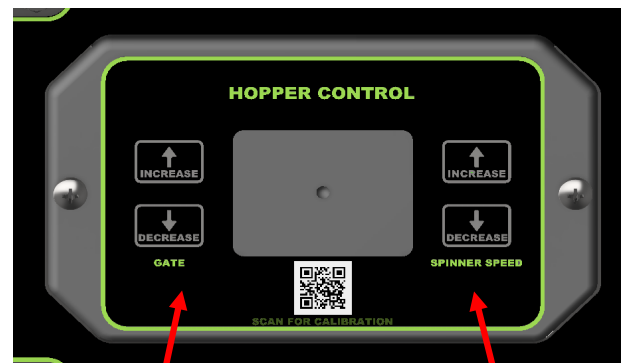

Fig. 1

GATE

SPINNER SPEED

## CONTROLS & OPERATION

### HALF-RATE GRANULAR CALIBRATION CHART:

		SPREAD WIDTH (Feet)									
		6	8	10	12	14	16	18	20	22	24
SPEED		BUCKET CATCH TIME (Seconds)									
		8 mph	7.5 mph	7 mph	6.5 mph	6 mph	5.5 mph	5 mph	4.5 mph	4 mph	3.5 mph
	8 mph	28.5	21.4	17.1	14.2	12.2	10.7	9.5	8.5	7.8	7.1
	7.5 mph	30.3	22.7	18.2	15.2	13	11.4	10.1	9.1	8.3	7.6
	7 mph	32.4	24.3	19.4	16.2	13.9	12.1	10.8	9.7	8.8	8.1
	6.5 mph	35	26.2	21	17.5	15	13.1	11.7	10.5	9.5	8.7
	6 mph	37.9	28.4	22.7	18.9	16.2	14.2	12.6	11.4	10.3	9.5
	5.5 mph	41.4	31	24.8	20.7	17.7	15.5	13.8	12.4	11.3	10.3
	5 mph	45.7	34.2	27.4	22.8	19.6	17.1	15.2	13.7	12.5	11.4
	4.5 mph	50.5	37.9	30.3	25.3	21.6	18.9	16.8	15.2	13.8	12.6
	4 mph	56.5	42.4	33.9	28.2	24.2	21.2	18.8	16.9	15.4	14.1
	3.5 mph	65	48.7	39	32.5	27.8	24.4	21.7	19.5	17.7	16.2
	3 mph	75.8	56.8	45.5	37.9	32.5	28.4	25.3	22.7	20.7	18.9

1,000 sq. ft. ÷ 1/2 spread width ÷ speed in fps = calibration time.

## NOTICE

To perform a granular calibration you will need a tape measure, bucket, and a scale.

- First - you will need to weigh the empty bucket and zero your scale (or note the weight of the bucket to subtract from your later measurement).
- Second - remove your spinner and place the bucket under the hopper. Place your white dial on setting number 5 (this is just a starting point). Using the above chart find the time you will need to open your hopper based on your desired speed and spread width.
- Third - open your hopper for the appropriate amount of time and then weigh the bucket (remember to subtract the weight of the empty bucket). Adjust the dial knob up or down and repeat until you have your desired lbs. per 1 thousand square feet (example if you want 4lbs per 1k sq. ft. you should have 4lbs of product in the bucket).
- Forth - stretch a tape measure out to your desired width on the ground in front of the machine and briefly open your hopper and adjust your spread width to match the width of your tape measure.

Your hopper is now calibrated. When applying product be sure to throw back to the center of your tire tracks from your previous pass. If needed use the Accuway diffuser to adjust your pattern so that the heaviest amount of product is directly in front of the machine.

## CONTROLS & OPERATION

### HOPPER DRAIN INSTRUCTIONS:

To drain the hopper:

- Place a bucket under the drain cap in front of the hopper.
- Remove the drain cap to drain the hopper.

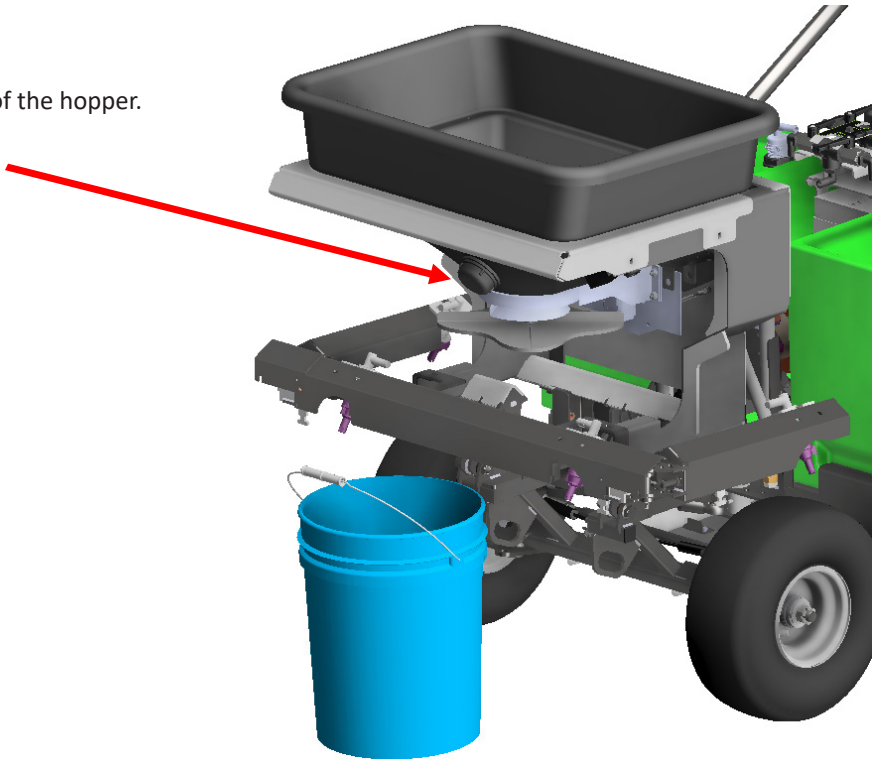

## CONTROLS & OPERATION

### SPRAY SYSTEM:

**STEP 1:** Select tanks.

### LIQUID TANKS:

- The SGLite model is equipped with 2 liquid tanks. The tanks can be operated in tandem or separately.
- The left tank is controlled by ball valves located in the center of the tanks (Fig. 4).
- The right tank is controlled by ball valves located in the center of the tanks.
- For the spray system to operate properly, at least one valve must be open. If the operator desires to pull from both tanks simultaneously, both valves must be open.

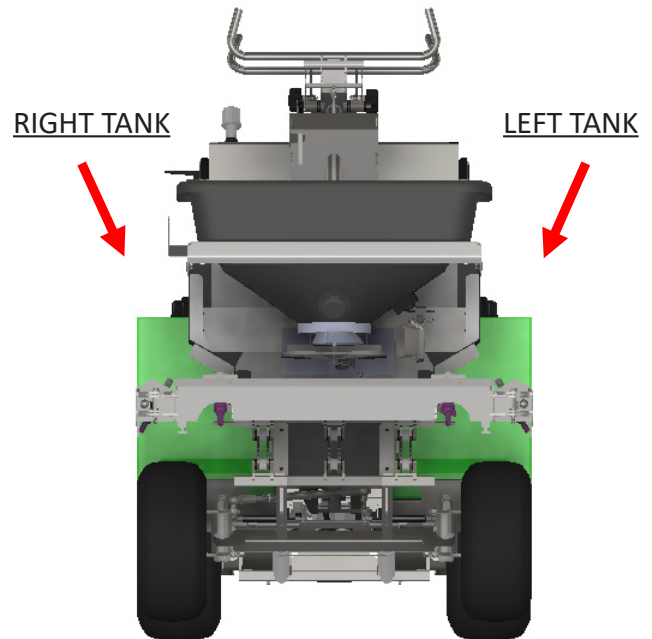

CONTROLS & OPERATION

RIGHT SIDE SUCTION & RETURN

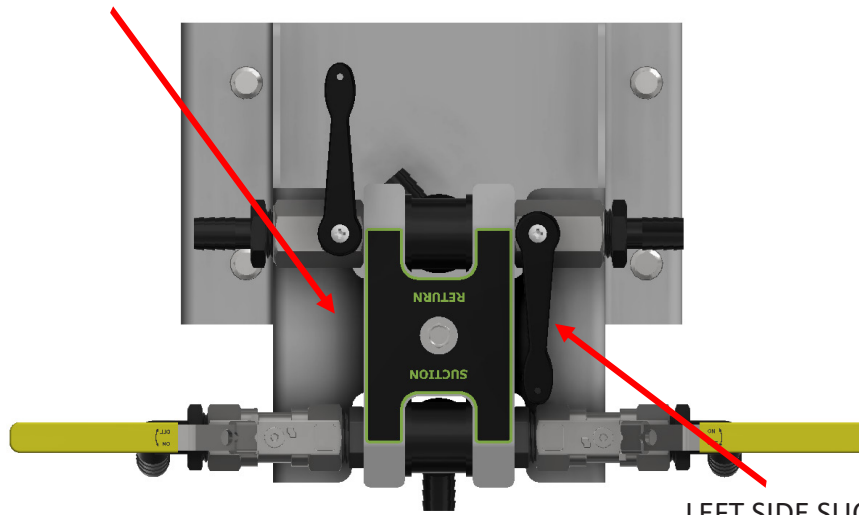

LEFT SIDE SUCTION & RETURN

Fig. 4

**STEP 2:** Turn the spray pump on by pressing the “rocker switch” on the dash panel (Fig. 5)

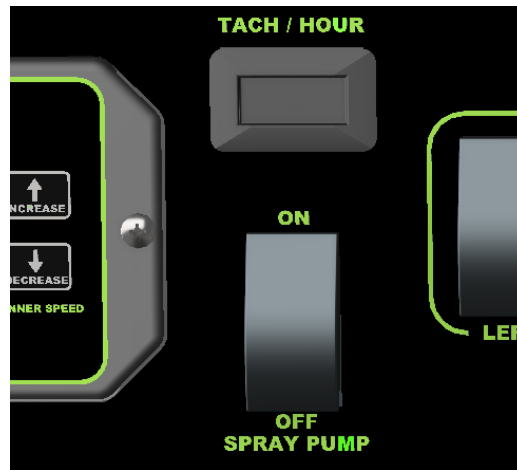

Fig. 5

## CONTROLS & OPERATION

### STEP 3: Adjust the spray pressure.

- Spray pressure is controlled by the pressure regulator located to the right of the dash panel.
- Pressure is increased by turning the pressure regulator clockwise (right) and decreased by turning counter-clockwise (left).
- Spray pressure is measured by the pressure gauge.



### NOTICE

- Use the *Spray Calibration Chart* to determine the desired spray pressure.
- The pressure will decrease when the Lever valves are opened.
- To create higher by-pass agitation, turn the Pressure Regulator fully clockwise. This will remove all restriction.

### STEP 4:

The spray boom consists of 3-sections: Left side, Center, & Right side (see below). Each boom section holds 1 nozzle.

### NOTICE

*Orientation is from the riders view, standing on the machine.*

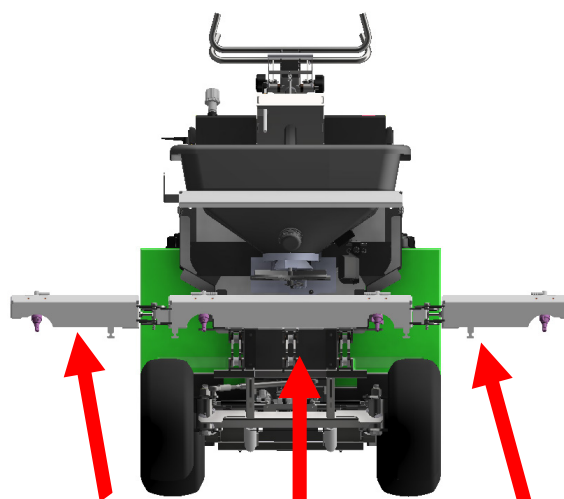

RIGHT SIDE

CENTER

LEFT SIDE

### STEP 5:

- Turn the spray boom sections “on” to begin spraying.
- Each section of the boom is controlled by a dedicated switch located on the dash panel.
- Select all 3 switches for full spray width or left, center, or right.
- The nozzles can also be powered on & off by pressing the “green thumb switch” on the handle bar. (Fig. 5)

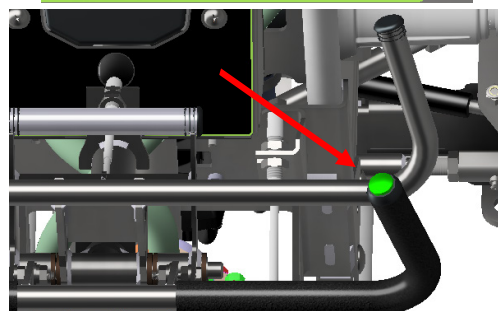
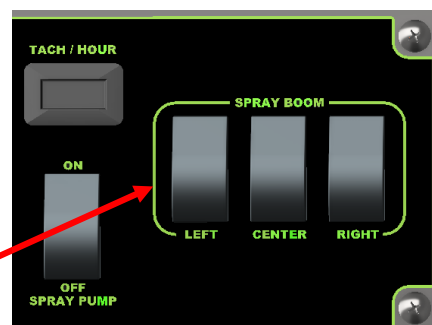

(Fig. 5)



## CONTROLS & OPERATION

TIP PART NO. (STRAINER MESH SIZE)	PSI	DROP SIZE	CAPACITY ONE TIP IN GPM	CAPACITY ONE TIP IN OZ/MIN	APPLICATION RATE FOR 20" SPRAY TIP SPACING														
					GALLONS PER ACRE (GPA)				GALLONS PER 1,000 SQ FT										
					4 MPH	5 MPH	6 MPH	8 MPH	3 MPH	4 MPH	5 MPH	6 MPH	7 MPH	8 MPH					
AIC11002 (50)	30	XC	0.17	22	12.6	10.1	8.4	6.3	0.39	0.29	0.23	0.19	0.17	0.14					
	40	XC	0.20	26	14.9	11.9	9.9	7.4	0.45	0.34	0.27	0.23	0.19	0.17					
	50	VC	0.22	28	16.3	13.1	10.9	8.2	0.50	0.37	0.30	0.25	0.21	0.19					
AIC110025 (50)	30	XC	0.22	28	16.3	13.1	10.9	8.2	0.50	0.37	0.30	0.25	0.21	0.19					
	40	XC	0.25	32	18.6	14.9	12.4	9.3	0.57	0.43	0.34	0.28	0.24	0.21					
	50	VC	0.28	36	21	16.6	13.9	10.4	0.63	0.48	0.38	0.32	0.27	0.24					
AIC11003 (50)	30	XC	0.26	33	19.3	15.4	12.9	9.7	0.59	0.44	0.35	0.29	0.25	0.22					
	40	XC	0.30	38	22	17.8	14.9	11.1	0.68	0.51	0.41	0.34	0.29	0.26					
	50	VC	0.34	44	25	20	16.8	12.6	0.77	0.58	0.46	0.39	0.33	0.29					
AIC11004 (50)	30	XC	0.35	45	26	21	17.3	13.0	0.79	0.60	0.48	0.40	0.34	0.30					
	40	XC	0.40	51	30	24	19.8	14.9	0.91	0.68	0.54	0.45	0.39	0.34					
	50	VC	0.45	58	33	27	22	16.7	1.0	0.77	0.61	0.51	0.44	0.38					
AIC11005 (50)	30	XC	0.43	55	32	26	21	16.0	0.97	0.73	0.58	0.49	0.42	0.37					
	40	XC	0.50	64	37	30	25	18.6	1.1	0.85	0.68	0.57	0.49	0.43					
	50	VC	0.56	72	42	33	28	21	1.3	0.95	0.76	0.63	0.54	0.48					
AIC11006 (50)	30	XC	0.52	67	39	31	26	19.3	1.2	0.88	0.71	0.59	0.51	0.44					
	40	XC	0.60	77	45	36	30	22	1.4	1.0	0.82	0.68	0.58	0.51					
	50	VC	0.67	86	50	40	33	25	1.5	1.1	0.91	0.76	0.65	0.57					
AIC11008 (50)	30	XC	0.69	88	51	41	34	26	1.6	1.2	0.94	0.78	0.67	0.59					
	40	XC	0.80	102	59	48	40	30	1.8	1.4	1.1	0.91	0.78	0.68					
	50	XC	0.89	114	66	53	44	33	2.0	1.5	1.2	1.0	0.86	0.76					
<b>HIGH VOLUME SPRAY CHART</b>																			
AIC11010	30	UC	0.87	111	65	52	43	32	2.0	1.5	1.2	0.99	0.85	0.74					
	40	XC	1.00	128	74	59	50	37	2.3	1.7	1.4	1.1	0.97	0.85					
	50	XC	1.12	143	83	67	55	42	2.5	1.9	1.5	1.3	1.1	0.95					
AIC11015	30	UC	1.30	166	97	77	67	48	2.9	2.2	1.8	1.5	1.3	1.1					
	40	XC	1.50	192	111	89	74	56	3.4	2.6	2.0	1.7	1.5	1.3					
	50	XC	1.68	215	125	100	83	62	3.8	2.9	2.3	1.9	1.6	1.4					

**NOTE:** Always double-check your application rates. Droplet size classification shown is based on ISO 25358. Droplet size classification standard is subject to change. Tabulations are based on spraying water at 70°F.

Mixing of liquid or dry product should be in accordance to manufacturers' labels. This machine is designed for low volume spraying, and the mix will be more concentrated.

This machine is factory set to put down 1/3 gallon of liquid per thousand square feet (at 5 mph and 40 PSI). For instance, some products call for 1.1 to 1.5 ounces per thousand square feet. It is recommended to use 1.3 ounces of product per thousand square feet (median value of 1.1 to 1.5).

If you were filling a 30-gallon tank, your equation would look like:  
 (Tank Capacity ÷ Spray Rate) x Chemical Rate = Amount of product in tank  
 Example: (30 gal ÷ .34 gal/l k) x 1.3 oz = 114.7 oz

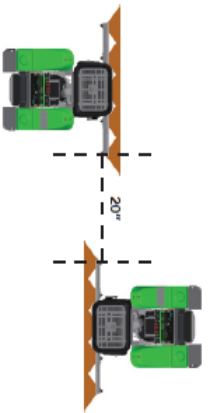

## CARE & MAINTENANCE

### WARNING

- Do not operate the engine in a confined space where carbon monoxide and other fumes can accumulate.
- Never lubricate, service, or adjust the machine or spreader while it is moving or running.
- Keep hands, feet, clothing, hair, and loose items away from any moving parts.

### CAUTION

- *Understand service and maintenance procedure before performing any work on this machine or spreader.*
- *Disconnect the battery before making any repairs.*
- *Keep all parts in good condition & operating properly.*
- *Fix damages immediately. Replace all worn or damaged parts.*
- *Check all hardware at frequent intervals to ensure they are tight.*

### MAINTENANCE TIPS

- Always avoid letting product sit in the tanks and pump for an extended period of time.
- Blowing off unit is preferred over washing. But if washing unit dry it off as best as possible.
- Refer to engine owner's manual for all other specs.

### HOPPER CLEANING:

- Use appropriate footwear, eye protection, and clothing when cleaning the spreader.
- The key to years of trouble-free service is to keep your spreader clean and dry.
- Never allow material to remain in hopper for extended periods of time.
- Empty material from hopper at the end of each day. See page 12 for hopper drain instructions.
- Use a hose or wipe excess material off of the spreader at the end of each day.
- Open and close the gate as you rinse to avoid buildup of material.
- Quickly towel dry the spreader.

### WINTERIZATION:

Proper winterization of the spray system helps to prevent damage to the system due to wintertime freezing. Follow these easy steps:

- 1 Drain all of the remaining liquid from the tanks and spray system.
- 2 Fill the tanks with enough RV antifreeze to fill the entire system.
- 3 Turn on the liquid pump and open all boom valves until solution is visible out of spray nozzles. Close boom valves.
- 4 Open valve for hose reel and begin spraying solution thru the nozzle.
- 5 Put the recommended amount of fuel stabilizer and follow the label for instructions.

## CARE & MAINTENANCE

SUGGESTED SERVICE	ACTION	DAILY	WEEKLY	BI-WEEKLY	MONTHLY	YEARLY	HOURS
Front Bearing Tubes	Grease				X		
Front Tie Rod Ends	Grease				X		
Front Tire Pressure	22 PSI		X				
Front Tire Bearing	Preload				X		
Rear Tire Pressure	18 PSI		X				
Rear Lug Nut	Torque 75 lbs.				X		
Rear Hub Castle Nut	Check the cotter pin				X		
Frame Hardware	Check all bolts & fastners				X		
Hopper Cables	Lubricate w/Silicone spray		X				
Accuway Cable							
Deflector Shield Cable							
Hopper Bottom Bushing	Change if needed				X	Replace	
Hopper Spinner				X			
<b>CLEAN SPINNER DAILY IF NEEDED</b>							
Engine Oil	Check	X					100 Hrs.
	Change						
Engine Air Filter	Check/Change if needed		X			Replace	
Engine Air Pre-Filter							
Engine Fuel Filter						Replace	
Engine Spark Plugs							
Hydraulic Oil	Change						500 HRS.
Hydraulic Oil Filter							
Hydraulic Oil Level	Check	X					
Hydro System Fittings	Check for leaks		X				
Chemical Leaks	Check		X				
Spray Nozzle Tips							
Spray Nozzle Tip Screens							
Spray Gun Tip							
Spray Nozzle Gasket							
Spray System Hoses					X		
In-Line Filter				X			
In-Line Filter Gasket				X			
Spray Gun Hose Reel\Coil Hose					X		
<b>SG MACHINES BLOW FERT OFF DAILY</b>							

The suggested maintenance schedule above is recommended for normal use, maintenance will vary for heavier use. SteelGreenMfg. reserves the right to determine usage.

## CARE & MAINTENANCE

### GREASE POINTS:

There are 7 grease points on the SGLite.

1. The front steering tubes (*both sides*).

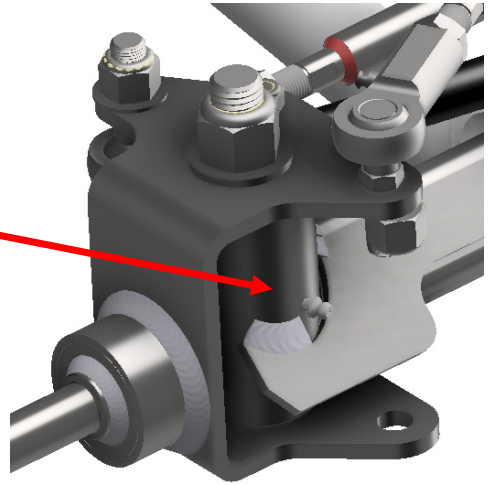

2. Upper & lower tie rods (*both ends*).

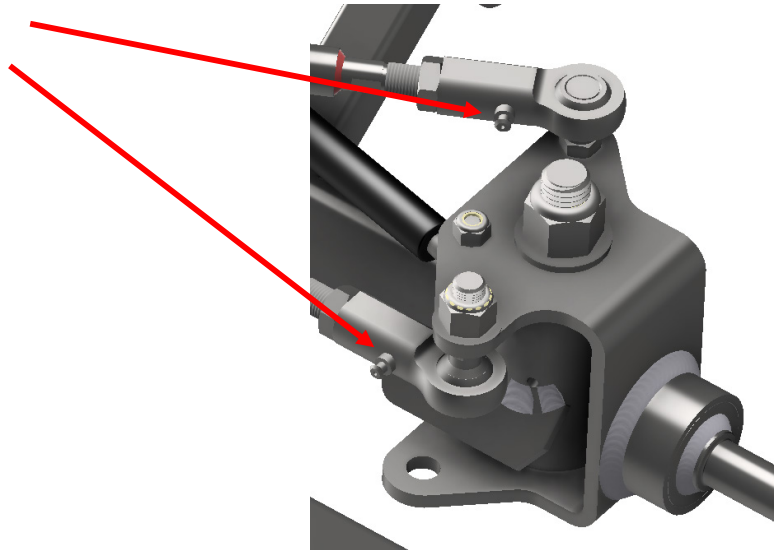

3. The steering column tube.

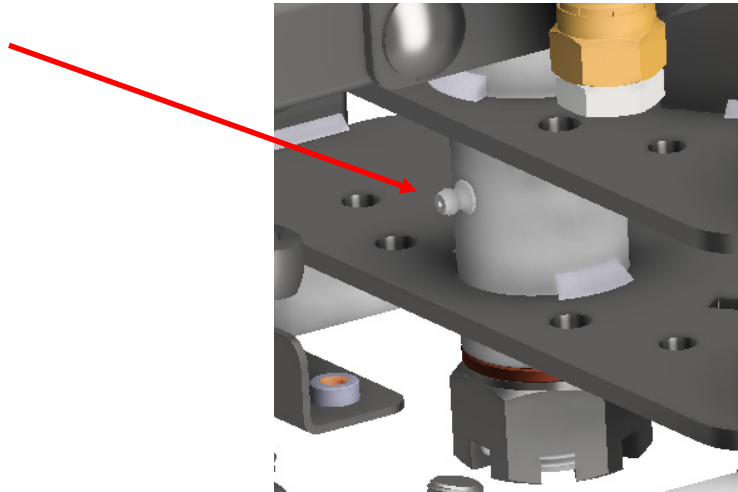

## CARE & MAINTENANCE

### ENGINE OIL CHANGE:

#### NOTICE

- Complete first engine oil change after 5 hour break in.
- Change engine oil every 100 hours with 5w50 full synthetic oil, API service classification SN, Resource conserving; ILSAC GF-5.

#### STEP 1:

- Remove the engine oil “dip stick”
- Loosen & remove the fill cap.

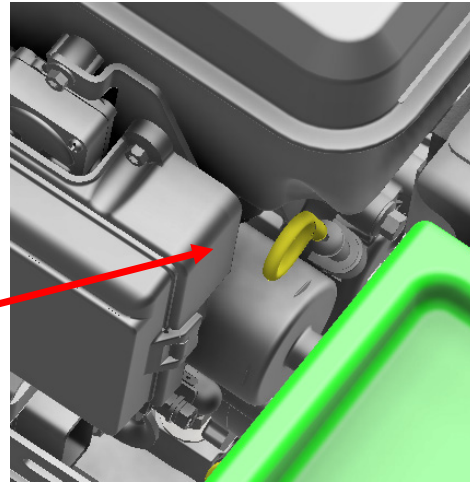

#### STEP 2:

- Remove the drain hose from the clip.
- Place the hose over a proper container & remove the plug from the hose to drain the oil.
- Once the oil is drained, reinstall the plug & attach the drain hose back to the clip.

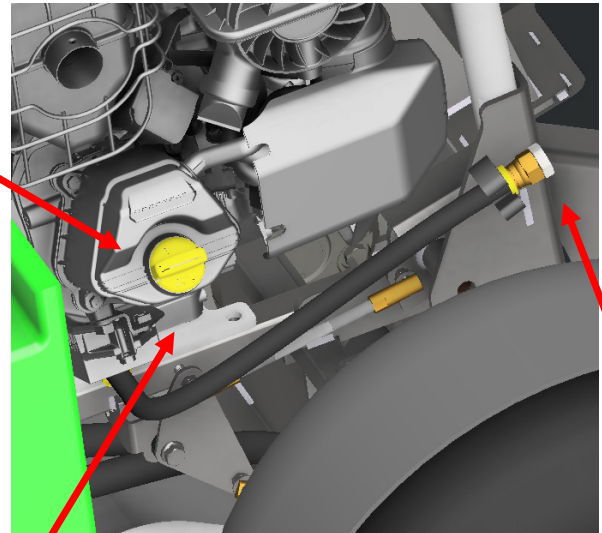

#### STEP 3:

- Refill the engine oil to proper level (32 ounces) with 5w50 full synthetic oil
- Check the “dip stick” to ensure proper oil level.
- Reattach the “dip stick” & “fill cap”

## CARE & MAINTENANCE

## CARE & MAINTENANCE

### HYDRAULIC OIL CHANGE:

#### NOTICE

*Change hydraulic oil & filter every 500 hours with 5w50 full synthetic oil, API service classification SN, Resource conserving; ILSAC GF-5.*

#### STEP 1:

- Remove the cap from the tank.
- Remove the drain hose from the clip.
- Place the hose over a proper container & remove the plug from the hose to drain the oil.
- Once the oil is drained, reinstall the plug & attach the drain hose back to the clip.
- If you choose to drain the oil from the wheel motor, reconnect the hose to the wheel motor.

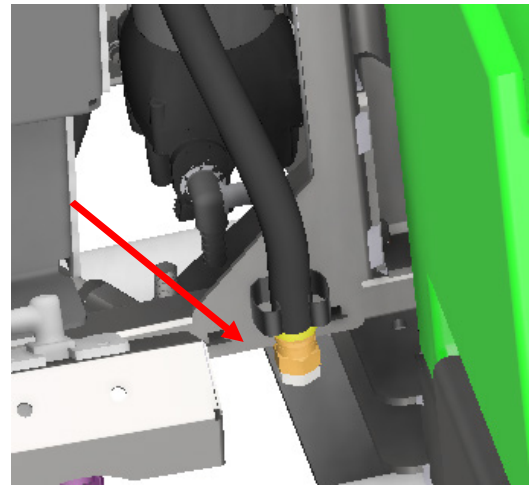
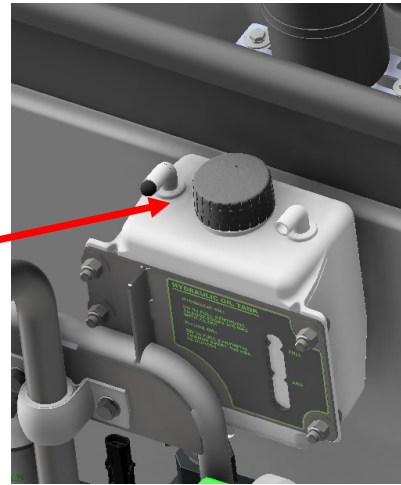

#### NOTICE

*To drain the most oil out as possible, you can also remove the rear tires & disconnect the hoses from the wheel motors to drain the oil at the lowest point.*

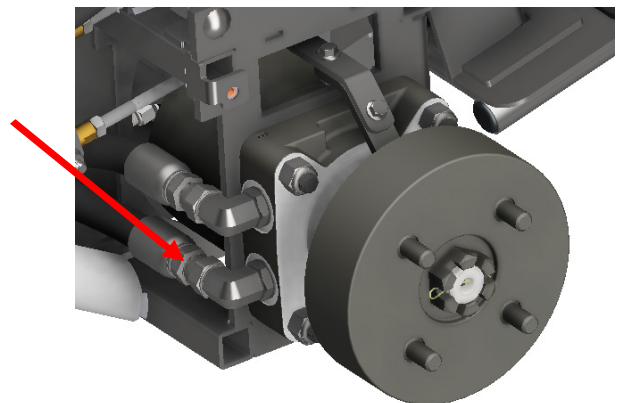

## CARE & MAINTENANCE

### HYDRAULIC OIL CHANGE:

**STEP 2:** Remove & replace the oil filter.

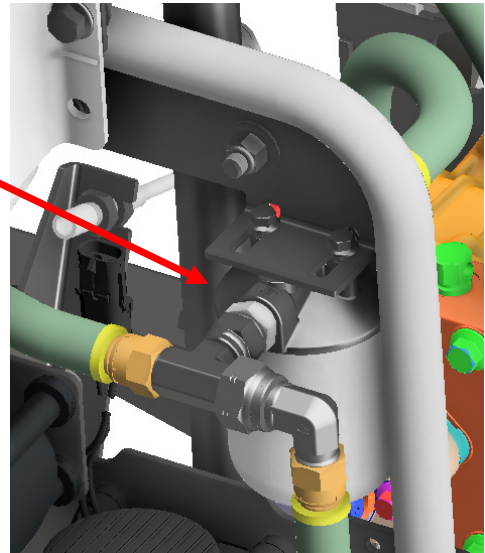

### STEP 3:

- Refill the hydraulic oil tank to the full line with 5w50 full synthetic oil.
- Use a floor jack & lift the back of the machine so the rear tires are off of the ground.
- Start & run the machine in forward & reverse to cycle the hydraulic oil back through the system, you will see the oil level drop in the hydraulic tank.
- Once the oil level has stopped, refill the hydraulic tank to the full line & reinstall the cap.
- If the rear tires have been removed, reattach the tires & lower the machine.

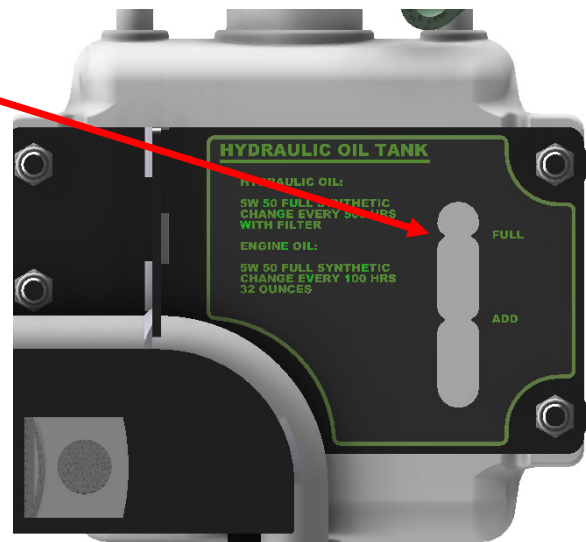

DRAWINGS & DIAGRAMS:

SPRAY SYSTEM SCHEMATIC

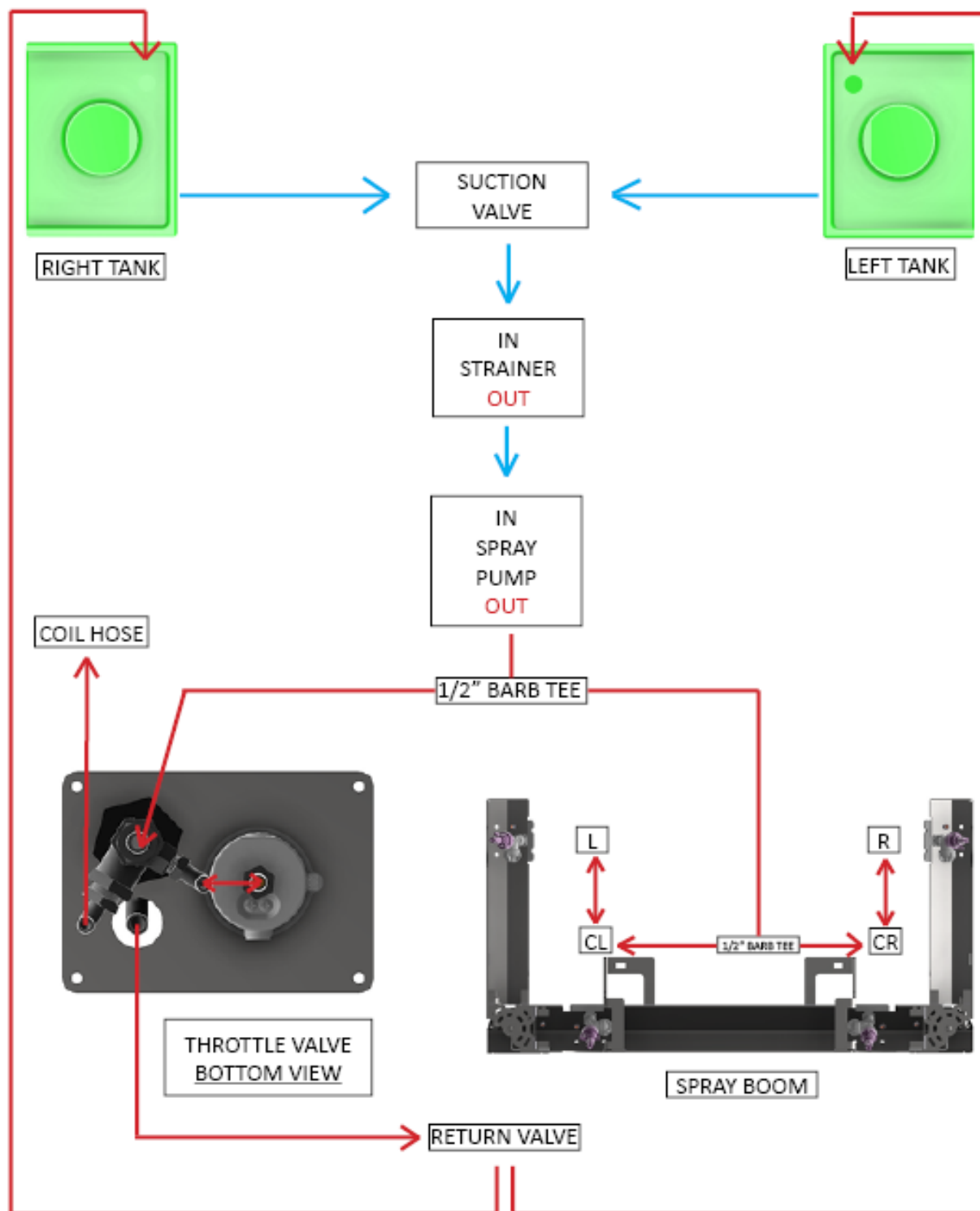

— SUCTION  
— RETURN

CARE & MAINTENANCE

HYDRAULIC SYSTEM

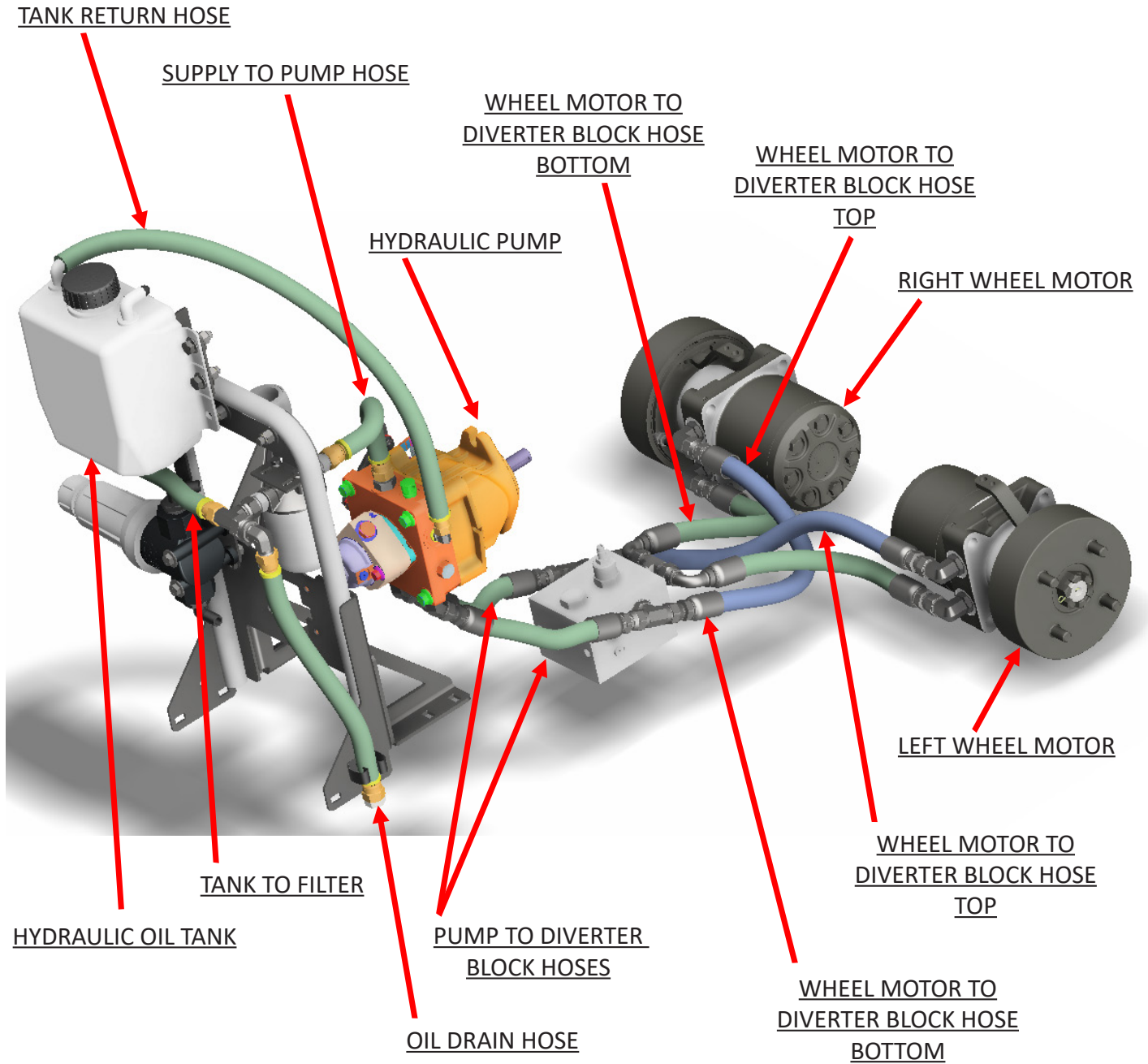



NOTES:



## Steel Green Manufacturing, LLC

### 1-Year Limited Warranty

- A. WHAT IS COVERED** – This Warranty applies to equipment having model numbers SG52, SG46, SG42, and SG36 (“Equipment”) manufactured by Steel Green Manufacturing, LLC, an Indiana limited liability company (“Steel Green”). This Warranty only applies to Equipment purchased directly from Steel Green or an authorized dealer or distributor of the Equipment (“Authorized Dealers”) in the United States. Except for Excluded Parts (as hereinafter defined), Steel Green agrees to repair or replace, at its option, any original component of the Equipment that is defective in material or workmanship (collectively “Warranty Service”). This Warranty begins on the date the product is delivered to the original purchaser and continues for a period of twelve (12) months thereafter (the “Warranty Term”).
- B. WHAT IS NOT COVERED** – This Warranty does not apply to the following categories of equipment: (1) used Equipment, unless there has been an Approved Transfer (as hereinafter defined); or (2) Equipment that has been altered or modified in ways not approved by Steel Green, including, but not limited to, setting injection pump fuel delivery above specifications stated in the owner’s manual. Furthermore, this Warranty does not apply to damage due to any of the following: (1) normal wear and tear; (2) the failure to perform reasonable and proper maintenance; (3) the failure to follow instructions and recommendations in the owner’s manual; (4) negligent or intentional misuse; (5) failure to properly store the Equipment; (6) vandalism; (7) the elements and inclement weather; or (8) collision or accident. “Excluded Parts” means the following parts, which are not covered by and are expressly excluded from this Warranty: (1) consumable parts, such as oil, filters, belts, brakes, and spark plugs; (2) tires; (3) batteries; and (4) the engine. The manufacturers of the Excluded Parts may provide a separate warranty. See manufacturers’ manuals for details.
- C. WHO IS COVERED** – This Warranty extends to the original purchaser of the Equipment who completes and returns the warranty registration card included with the Equipment to Steel Green and to any subsequent owner (collectively “you”), provided the subsequent owner notifies Steel Green of the change in ownership and Steel Green approves the transfer of this Warranty (“Approved Transfer”). An Approved Transfer does not extend the Warranty Term.
- D. HOW IS WARRANTY SERVICE OBTAINED** – To obtain Warranty Service, you must: (1) report the Equipment defect to Steel Green within the Warranty Term; and (2) deliver the Equipment for Warranty Service within a reasonable time thereafter. All Warranty Service must use new or remanufactured parts or components furnished or approved by Steel Green and must be performed by Steel Green, an Authorized Dealer, or a service center approved by Steel Green (“Authorized Service Center”), as directed by Steel Green. This Warranty only covers the costs of parts and labor associated with Warranty Service. You are responsible for delivering the Equipment for Warranty Service, at your sole cost and expense. Steel Green is not responsible for any costs or liability associated with any pickup, delivery, or other transportation required to obtain Warranty Service.
- E. ADDITIONAL LIMITATIONS AND EXCLUSIONS** – Except as expressly provided herein, Steel Green makes no warranties, representations, conditions or promises, express or implied, as to the quality, performance or freedom from defect of the Equipment covered by this Warranty. STEEL GREEN DOES NOT MAKE ANY STATUTORY OR IMPLIED WARRANTIES OR CONDITIONS OF MERCHANTABILITY OR FITNESS FOR A PARTICULAR PURPOSE, AND SUCH WARRANTIES ARE EXPRESSLY DISCLAIMED. TO THE EXTENT THEY ARE LEGALLY REQUIRED, ANY IMPLIED WARRANTIES OR CONDITIONS SHALL BE LIMITED IN DURATION TO THE WARRANTY TERM.



STEEL GREEN'S ONLY LIABILITY WITH RESPECT TO THIS WARRANTY AND YOUR EXCLUSIVE REMEDY SHALL BE FOR THE REPAIR OR REPLACEMENT OF PARTS AS SET FORTH HEREIN. NO CLAIM FOR BREACH OF WARRANTY SHALL ENTITLE YOU TO CANCELLATION OR RESCISSION OF THE PURCHASE OF THE EQUIPMENT.

IN NO EVENT WILL ANY AUTHORIZED DEALER, ANY AUTHORIZED SERVICE CENTER, STEEL GREEN OR ANY COMPANY AFFILIATED WITH STEEL GREEN BE LIABLE FOR INCIDENTAL OR CONSEQUENTIAL DAMAGES. Examples of such damages include, but are not limited to: (1) the loss or damage to person or property other than that covered by this Warranty; (2) attorneys' fees; (3) claims for lost revenue or lost profits; and (4) rental costs of similar equipment to the Equipment.

SOME STATES DO NOT ALLOW THE EXCLUSION OR LIMITATION OF INCIDENTAL OR CONSEQUENTIAL DAMAGES, OR LIMITATIONS ON THE DURATION OF AN IMPLIED WARRANTY, SO THE ABOVE LIMITATIONS AND EXCLUSIONS MAY NOT APPLY TO YOU. THIS WARRANTY GIVES YOU SPECIFIC LEGAL RIGHTS, BUT YOU MAY ALSO HAVE OTHER RIGHTS, WHICH VARY FROM STATE TO STATE.

- F. NO OTHER WARRANTIES** – NO OTHER PERSON OR ENTITY, INCLUDING ANY AUTHORIZED DEALER, HAS AUTHORITY TO MAKE ANY WARRANTY, REPRESENTATION, CONDITION OR PROMISE ON BEHALF OF STEEL GREEN, OR TO MODIFY THE TERMS OR LIMITATIONS OF THIS WARRANTY IN ANY WAY, WHETHER ORALLY OR IN WRITING. STEEL GREEN MAKES NO OTHER WARRANTY RELATED TO THE EQUIPMENT OR ANY OTHER ITEM UNLESS IT DELIVERS TO YOU A SEPARATE WRITTEN WARRANTY.
- G. CONTACT** – To obtain a replacement warranty registration card or report a defect in any Equipment, to find the nearest Authorized Dealer or Authorized Service Center or report your dissatisfaction with their assistance, or to otherwise obtain information regarding this Warranty, please contact Steel Green.

Steel Green Manufacturing LLC  
Attn: Customer Service  
824 S State Road 39  
Lebanon, Indiana 46025  
(765) 481-2890  
sales@steelgreenmfg.com  
Steelgreenmfg.com



# STEELGREEN MANUFACTURING™

## WARRANTY REGISTRATION FORM

Fill out this form completely and return to **Steel Green Manufacturing.**

**Email:** sales@steelgreenmfg.com

**Mail:** 824 S State Road 39, Lebanon, IN 46052

## CONTACT INFORMATION

Company Name: \_\_\_\_\_

Contact Name: \_\_\_\_\_

Street: \_\_\_\_\_

City: \_\_\_\_\_ State: \_\_\_\_\_ ZIP Code: \_\_\_\_\_

Phone: \_\_\_\_\_ Email: \_\_\_\_\_

## MACHINE INFORMATION

Serial Number: \_\_\_\_\_ Date of Purchase: \_\_\_\_\_



Dealer Name: \_\_\_\_\_

Street: \_\_\_\_\_

City: \_\_\_\_\_ State: \_\_\_\_\_ ZIP Code: \_\_\_\_\_

Phone: \_\_\_\_\_ Salesperson: \_\_\_\_\_



steelgreenmfg.com (765) 481-2890    @SteelGreenMFG

