

STEELGREEN MANUFACTURING™



SG SERIES

MODELS: SG36, SG42, SG46, & SG52

ZERO-TURN SPREADER/SPRAYER

OPERATOR & SERVICE MANUAL

For additional information, please visit us at www.steelgreenmfg.com



MADE IN THE USA

TABLE OF CONTENTS

GENERAL INFORMATION	3
SPECIFICATIONS	4
SAFE OPERATION	5
CONTROLS AND OPERATION	6
DASH PANEL	6
STRIKER SET-UP	6
OPERATION	7
SPREADER	9
SPREADER CALIBRATION CHART	10
HOPPER DRAIN INSTRUCTIONS	11
SPRAY SYSTEM	12
STANDARD VOLUME SPRAY CHART	16
CARE & MAINTENANCE	17
DRAWINGS & DIAGRAMS	24
NOTES	29
WARRANTY	33



GENERAL INFORMATION

Thank you for purchasing a Steel Green machine! Please read and understand this manual before operating this piece of equipment. This manual will assist you in areas of operation, safety, and maintenance. Any unresolved question can be directed to Steel Green Mfg. We at Steel Green are excited to hear feedback from our customer base so we can continue to provide you with the most productive and efficient equipment possible

NOTICE

This manual and all information and illustrations were accurate at the time of publication. Steel Green Mfg. reserves the right to make changes without notice.

IMPORTANT: READ SAFETY RULES AND INSTRUCTIONS CAREFULLY.

WARNING

Steel Green units are equipped with an internal combustion engine and should not be used on or near any unimproved forest-covered, brush-covered or grass-covered land unless the engine's exhaust system is equipped with a spark arrester meeting applicable local or state laws (if any). If a spark arrester is used, it should be maintained in effective working order by the operator. In the State of California, the above is required by law (Section 4442 of the California Public Resources Code). Other states may have similar laws. Federal laws apply on federal lands. A spark arrester for the muffler is available through your nearest engine authorized service dealer or contact the service department .

Serial Number: _____

Date Purchased: _____

Dealer Name: _____

Dealer Phone Number: _____

SPECIFICATIONS

DIMENSIONS:

MODEL SG36

MODEL SG46

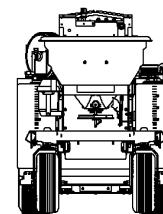
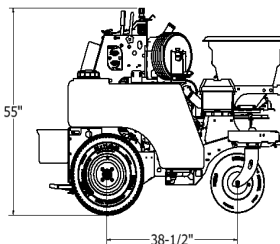
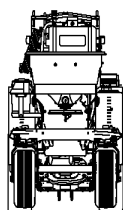
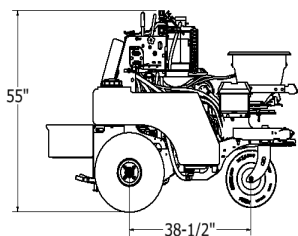
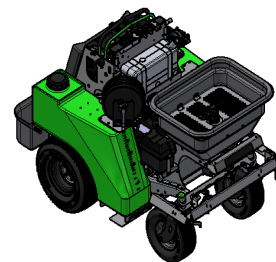
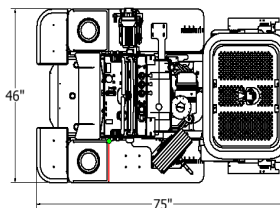
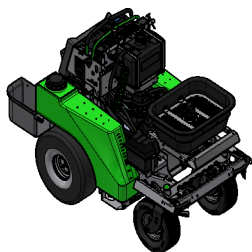
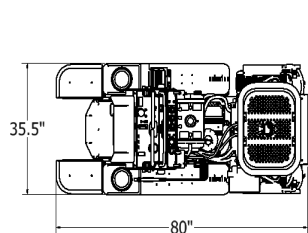

MODEL SG52

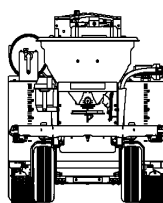
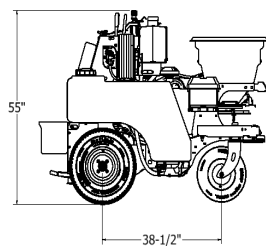
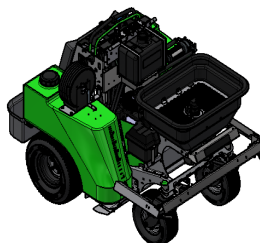
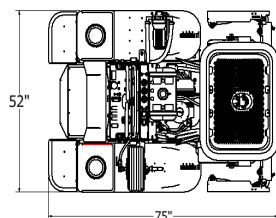

DESCRIPTION	<i>SG36</i>	<i>SG46</i>	<i>SG52</i>
WEIGHT	935	950	970
FRONT TIRE	16 X 6.50-8		
REAR TIRE	21 X 7.00-10	22 X 11.00-10	
SPRAY CAPACITY	30 GAL.	50 GAL.	60 GAL.
SPRAY WIDTH	2',4',6' OR 8'		2',6',8' OR 10'
HOPPER CAPACITY	125 lbs.	225 lbs.	
VARIABLE SPREAD WIDTH	Up to 25'		
FUEL CAPACITY	5 GAL.		
TRANSPORT SPEED	Up to 10 mph		
RATE PRODUCTION	120,000 sq. ft. per fill based on 1/4 gal. spray nozzles.	240,000 sq. ft. per fill based on 1/4 gal. spray nozzles.	

SAFE OPERATION

 **CAUTION**

THE FOLLOWING IMPORTANT SAFETY INSTRUCTIONS WHICH, IF NOT FOLLOWED, COULD ENDANGER THE PERSONAL SAFETY AND/OR PROPERTY OF YOURSELF AND OTHERS. READ AND FOLLOW ALL INSTRUCTIONS IN THIS MANUAL BEFORE ATTEMPTING TO OPERATE YOUR UNIT. FAILURE TO COMPLY WITH THESE INSTRUCTIONS MAY RESULT IN PERSONAL INJURY.

 **GENERAL OPERATION:**

- Do not operate the machine while under the influence of alcohol or drugs.
- Only allow responsible adults, who have practiced driving a Steel Green machine and are familiar with the instructions to operate the machine. Local restrictions may restrict the age of the operator.

 **RE-FUELING:**

- ALWAYS STOP THE ENGINE and allow it to cool before refueling. NEVER remove the gas cap to add fuel while the engine is running, and never fill the gas tank on an engine that has been running and is still hot – gas spilled on a hot engine can ignite.
- Never smoke while refueling.
- Do not overfill fuel tank.
- Follow warning label on fuel tank.

 **SLOPE OPERATION:**

- Cease operation if stability is questionable, or if you are unsure of the ability to continue safely.
- Keep alert for hidden hazards on the terrain.
- Stay away from drop-offs, ditches and embankments.
- Never operate on slope angles greater than 10° with a Steel Green machine in its basic configuration. Basic configuration is defined as a Steel Green machine with a hopper & no attachments. (A 10° slope is a slope that rises 1 m (3.5 ft) over a horizontal distance of 6.1 m (20 ft).)
- When using attachments, never operate a Steel-Green machine on slope angles greater than 10°. The addition of an extra tank, or other attachments. Attachments will increase the risk of a rollover. (A 10° slope is a slope that rises 1 m (3.5 ft) over a horizontal distance of 6.1 m (20 ft).)

CONTROLS & OPERATION

DASH PANEL

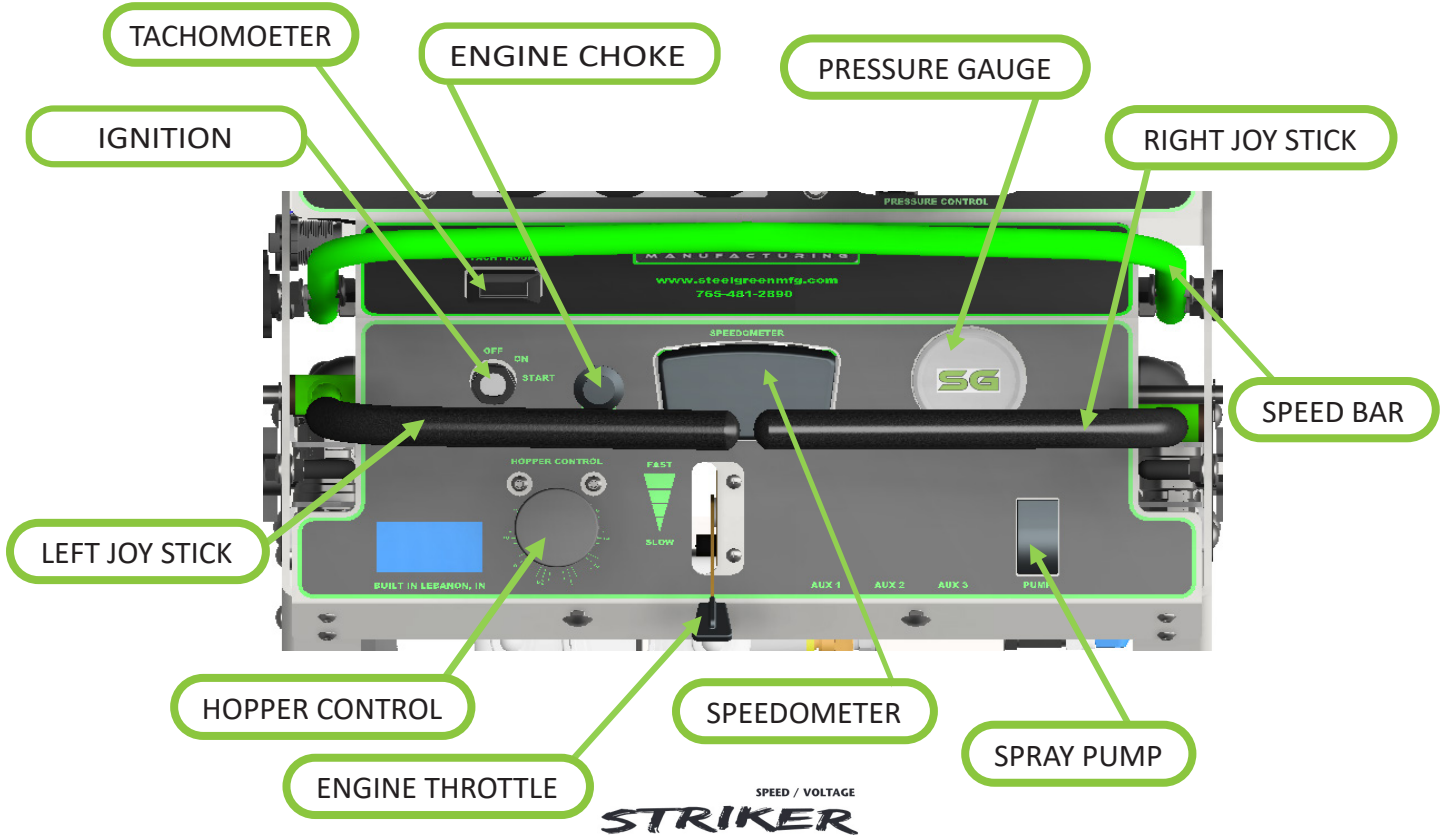

Setup Mode



Overview:

Description: Setup mode is crucial for Striker to operate correctly.

SETTINGS ORDER	VALUE	DEFAULT
A. Distance Units	KM/H or M/H	M/H
B. Tire Size	Millimeters	2109mm
C. Clock	12Hr or 24Hr	12Hr
	Time-of-Day	12:00:00
D. Temperature	°F or °C	°F
E. LED Alerts	Temperature High Alert	000°
	Temperature Danger Alert	000°
	Voltage Low Alert	0V
	Voltage Danger Alert	0V
F. Maintenance	Oil Countdown	0000 M/H
	Care Countdown	0000 M/H
G. AVG SPD	Screen 2 or 3	Screen 3
H. Distance	Resolution	Res 2

Enter Setup Mode:

HOLD DOWN ALL THREE BUTTONS FOR 3 SECONDS.



All segments on the screen will turn black. Release to continue.

Setup Mode

Setup Distance Units:

Striker defaults to M/H.



TO CYCLE BETWEEN M/H AND KM/H, PRESS THE LEFT BUTTON.



TO CONFIRM, PRESS THE CENTER BUTTON.

Striker will move on to the next setting.



Setup Wheel Size:

See "Measure Wheel Size" on page 16 for more information.
SG52, 46, & 42 with 22 X 11 X 10 tire: Enter - 1755



SG36 with 21 X 7 X 10 tire: Enter - 1705

MODIFY DIGIT: LEFT BUTTON

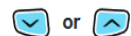

NEXT DIGIT: RIGHT BUTTON

TO CONFIRM, PRESS THE CENTER BUTTON.

Striker will move on to the next setting.



NOTICE

Red & Amber blinking lights indicate battery voltage is below 12 volts.

CONTROLS & OPERATION

MACHINE OPERATION:

- To drive the machine, step up on the foot board and rest against the chest pad.

PARKING BRAKE OPERATION:

- Disengage the parking brake.

CHEST PAD

FOOT BOARD

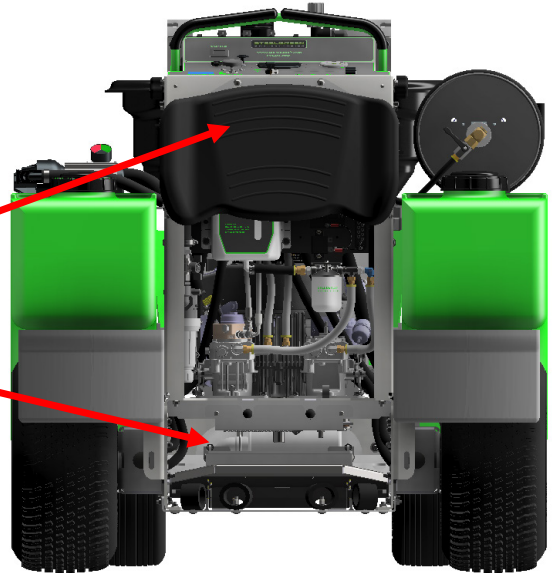

NOTICE

- To engage the parking brake, push the pedal down.
- To release the parking brake, pull the pedl up.

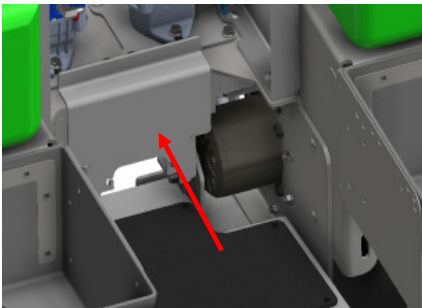

BRAKE DISENGAGED

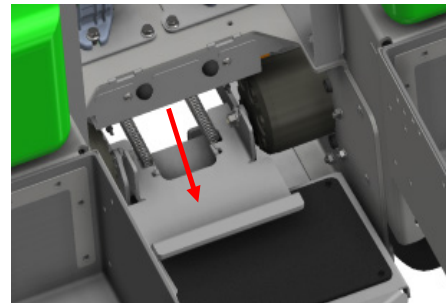

BRAKE ENGAGED

- Move the throttle lever about half throttle.
- Pull the choke out.
- Turn the key to start the machine.
- Push the choke back in once the machine is running.



CONTROLS & OPERATION

JOY STICKS:

- The left joy stick maneuvers the left tire forward and reverse.
- The right joy stick maneuvers the right tire forward and reverse.

DRIVING THE MACHINE:

- Move both joy sticks forward to drive forward.
- Move both joy sticks back to drive in reverse.
- To maneuver a left turn move the right joy stick forward and pull the left one back.
- To maneuver a right turn move the left joy stick forward and pull the right one back.

LEFT TURN

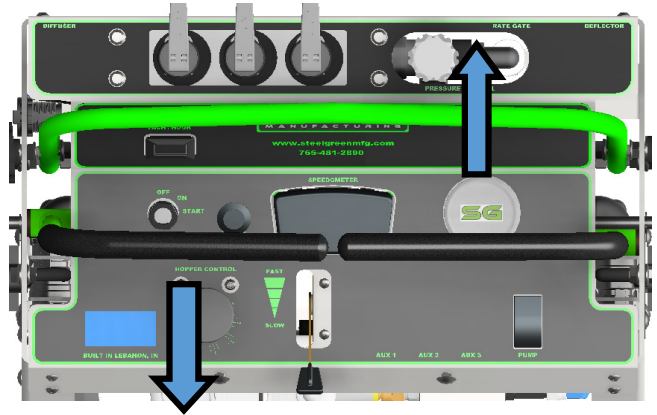

RIGHT TURN

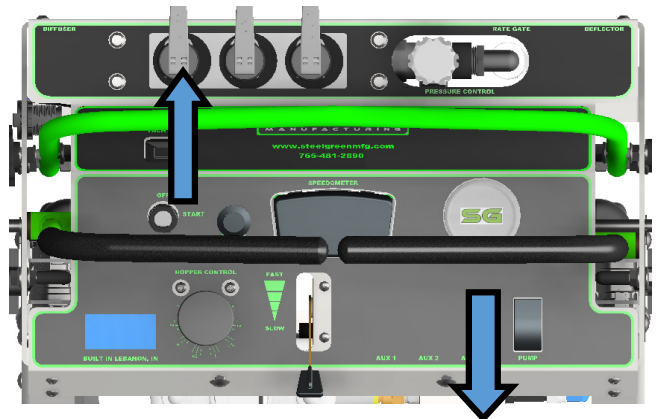

SPEED BAR:

- The speed bar is used to set the maximum speed for spray applications.
- Adjust the speed bar by loosening the black knobs on both sides.
- Move both the joy sticks and speed bar together to set the desired max. speed and tighten the knobs.

SPEED BAR

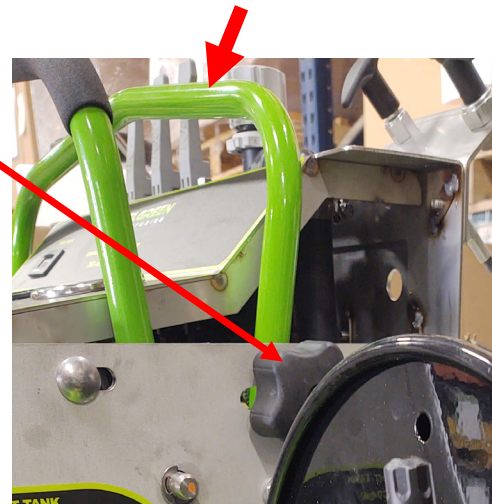

CONTROLS & OPERATION

SPREADER:

CAUTION

- *To avoid injury to the hand, ensure the engine is turned OFF before adjusting.*
- *Wear appropriate clothing & safety equipment when applying & handling chemicals.*

- Earthway balances the spread pattern by shifting the product placement on the spinner. Placing the product on the impeller close to the shaft or the center will cause the spread pattern to be heavier to the right as it rides the impeller for a longer period. If the product is placed on the outer edge of the impeller, the spread pattern will be heavier to the left as the spinner turns clockwise.
- Start with the Accuway control cable all the way forward or in.
- Begin to spread the product. As you are spreading, you should be able to see the spread pattern in front of you. Generally, all spreaders will tend to throw fertilizer heavy to the right. As you continue to spread, pull the Accuway control towards you very slowly in small increments. This will bring the spread pattern dead center in front of you.
- Once you have the spread pattern “dead center,” lock the Accuway cable in place. There should be no reason to reset the Accuway for that product unless you see the spread pattern has changed due to bumping the lever. If it has changed slightly, simply readjust the pattern as you are spreading.

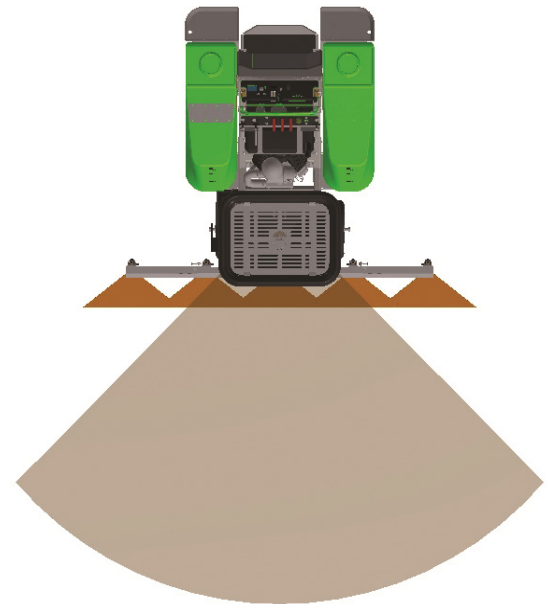

**THROW FERTILIZER
TO CENTER OF TIRE TRACKS**

CONTROLS & OPERATION

HALF-RATE GRANULAR CALIBRATION CHART:

		SPREAD WIDTH (Feet)									
		6	8	10	12	14	16	18	20	22	24
SPEED		BUCKET CATCH TIME (Seconds)									
		8 mph	7.5 mph	7 mph	6.5 mph	6 mph	5.5 mph	5 mph	4.5 mph	4 mph	3.5 mph
	8 mph	28.5	21.4	17.1	14.2	12.2	10.7	9.5	8.5	7.8	7.1
	7.5 mph	30.3	22.7	18.2	15.2	13	11.4	10.1	9.1	8.3	7.6
	7 mph	32.4	24.3	19.4	16.2	13.9	12.1	10.8	9.7	8.8	8.1
	6.5 mph	35	26.2	21	17.5	15	13.1	11.7	10.5	9.5	8.7
	6 mph	37.9	28.4	22.7	18.9	16.2	14.2	12.6	11.4	10.3	9.5
	5.5 mph	41.4	31	24.8	20.7	17.7	15.5	13.8	12.4	11.3	10.3
	5 mph	45.7	34.2	27.4	22.8	19.6	17.1	15.2	13.7	12.5	11.4
	4.5 mph	50.5	37.9	30.3	25.3	21.6	18.9	16.8	15.2	13.8	12.6
	4 mph	56.5	42.4	33.9	28.2	24.2	21.2	18.8	16.9	15.4	14.1
	3.5 mph	65	48.7	39	32.5	27.8	24.4	21.7	19.5	17.7	16.2
	3 mph	75.8	56.8	45.5	37.9	32.5	28.4	25.3	22.7	20.7	18.9
		1,000 sq. ft. ÷ 1/2 spread width ÷ speed in fps = calibration time.									

NOTICE

To perform a granular calibration you will need a tape measure, bucket, and a scale.

- First - you will need to weigh the empty bucket and zero your scale (or note the weight of the bucket to subtract from your later measurement).
- Second - remove your spinner and place the bucket under the hopper. Place your white dial on setting number 5 (this is just a starting point). Using the above chart find the time you will need to open your hopper based on your desired speed and spread width.
- Third - open your hopper for the appropriate amount of time and then weigh the bucket (remember to subtract the weight of the empty bucket). Adjust the dial knob up or down and repeat until you have your desired lbs. per 1 thousand square feet (example if you want 4lbs per 1k sq. ft. you should have 4lbs of product in the bucket).
- Forth - stretch a tape measure out to your desired width on the ground in front of the machine and briefly open your hopper and adjust your spread width to match the width of your tape measure.

Your hopper is now calibrated. When applying product be sure to throw back to the center of your tire tracks from your previous pass. If needed use the Accuway diffuser to adjust your pattern so that the heaviest amount of product is directly in front of the machine.

CONTROLS & OPERATION

HOPPER DRAIN INSTRUCTIONS:

STEP 1: Squeeze and rotate the spring to disconnect it from the rod, then pull it out of the spinner.

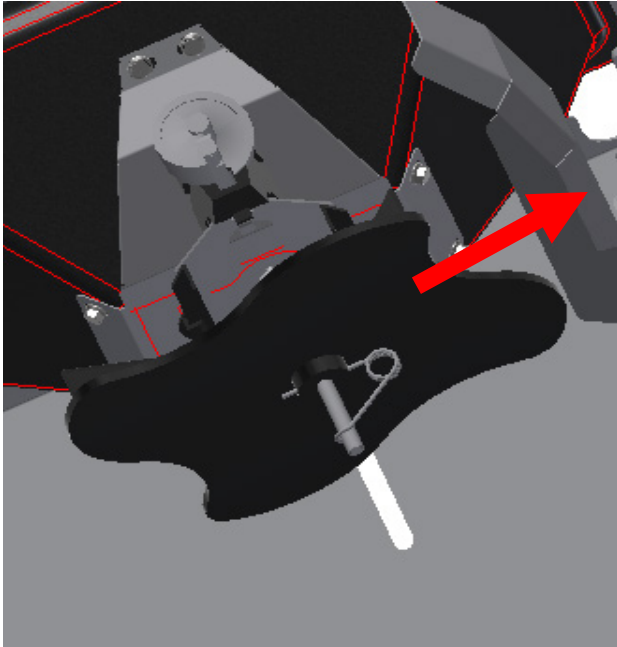

STEP 2: Slide the spinner off of the rod.

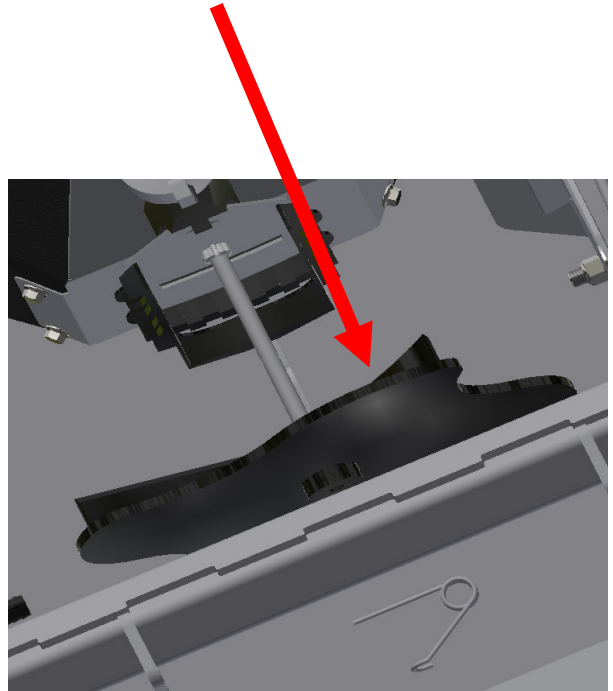

NOTICE

It may be necessary to loosen the bolt & move the rod up to allow enough room to remove the spinner.

STEP 3: Place a bucket under the hopper trap, open the trap door to drain the hopper.

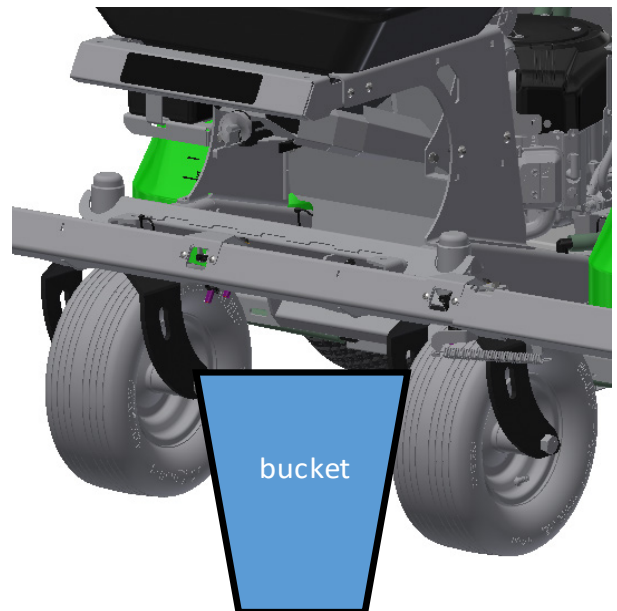
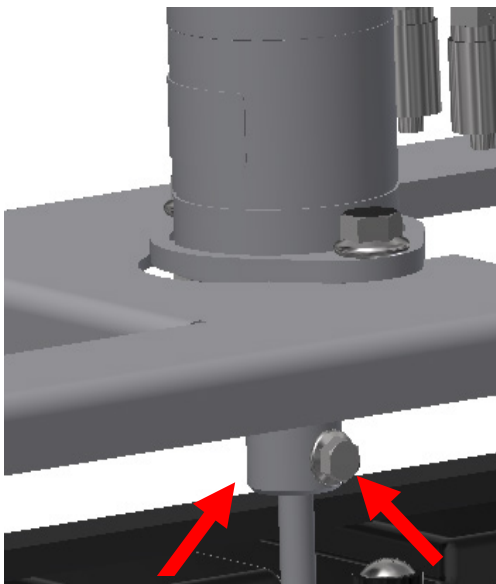

CONTROLS & OPERATION

SPRAY SYSTEM:

STEP 1: Select tanks or hose reel.

LIQUID TANKS:

- Each SG Series model is equipped with 2 Liquid Tanks. The tanks can be operated in tandem or separately.
- The left tank is controlled by 2 valves located on the left side of the upright. upper valve controls the suction, and Lower valve controls the return.
- The right tank is controlled by 2 valves located on the right side of the upright. upper valve controls the suction, and lower valve controls the return.
- For the spray system to operate properly, at least one return valve and one suction valve must be open. If the operator desires to pull from both tanks simultaneously, all 4 valves must be open.
- To pull from the either the left of right-side tanks, the corresponding valves must be open.

RIGHT TANK

LEFT TANK

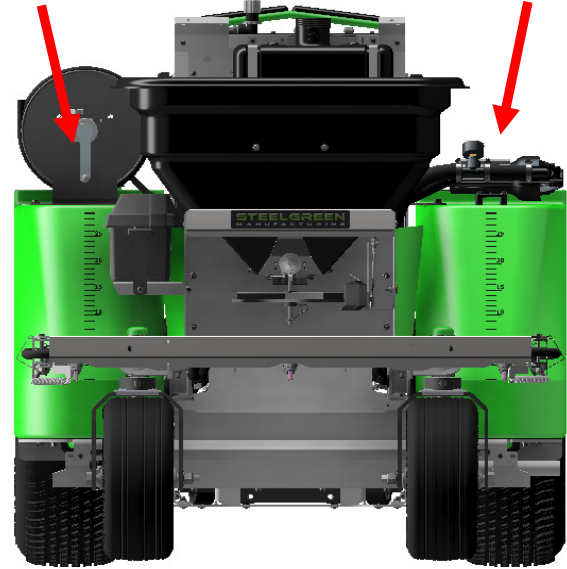

HOSE REEL:

- Each SG Series model is also equipped with either a 75' hose reel (SG52, SG46, SG42) or a 15' Coil Hose (SG36). This is meant to assist with spot spraying and or areas that are not able to be reached by the machine.
- To operate, turn on pump switch, make sure the lever valves are turned off.
- Use the proper pressure dictated in the Spray Calibration chart.

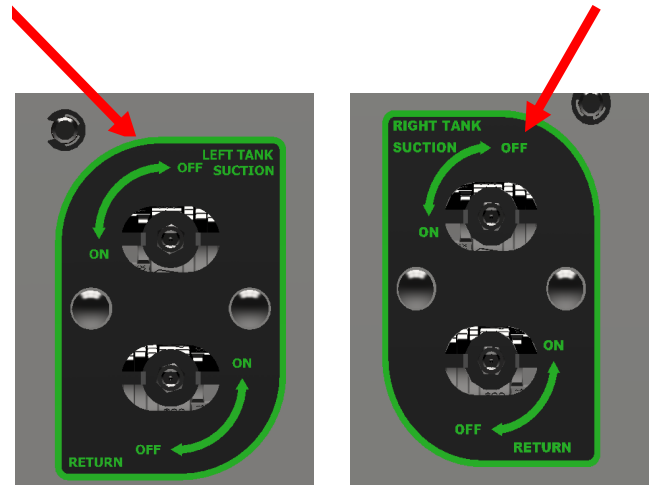

CONTROLS & OPERATION

SPRAY SYSTEM:

- The hose reel or Coil Hose is turned on by a chrome valve.
- To apply press the handle together and mimic the spray pattern from the boom.

NOTICE

Make sure the hose reel or coil hose valve is turned off while not in use. Otherwise back pressure may be created & will cause the nozzle tips to drip.

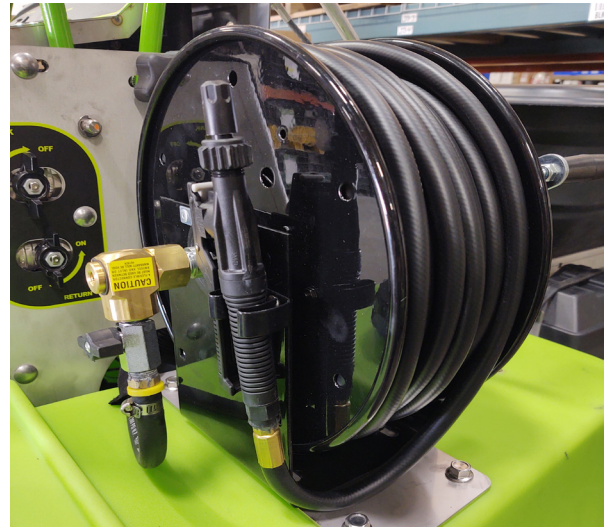

STEP 2: Turn the spray pump on.

- The spray pump is turned on/off by one of two ways. A constant rocker switch is located on the dash panel. This pump will constantly run when the switch is pushed in the on position.
- A momentary spot spray switch is located on the left side of the operator's foot plate. This switch will only turn the pump on while depressed. Once pressure is lifted from the switch, the pump will shut off.

NOTICE

If the constant rocker switch is in the "on" position, the momentary switch will not function.

DASH



FOOTBOARD



CONTROLS & OPERATION

SPRAY SYSTEM:

STEP 3: Adjust the spray pressure.

- Spray pressure is controlled by the pressure regulator located to the right of the boom control valves.
- Pressure is increased by turning the pressure regulator clockwise (right) and decreased by turning counterclockwise (left).
- Spray pressure is measured by the pressure gauge.



NOTICE

- Use the Spray Calibration Chart to determine the desired spray pressure.
- The pressure will decrease when the Lever valves are opened.
- To create higher by-pass agitation, turn the Pressure Regulator fully clockwise. This will remove all restriction.

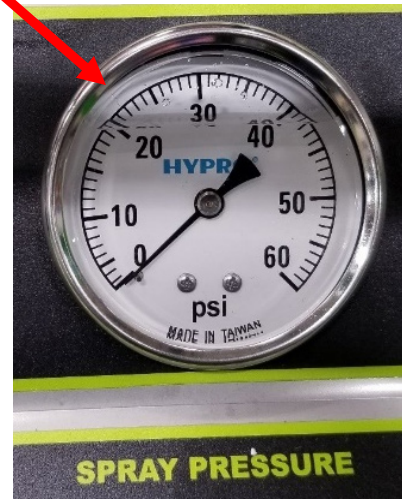

CONTROLS & OPERATION

SPRAY SYSTEM:

STEP 4: Open the valves to begin spraying.

The spray boom consists of 3-sections: Left Wing, Center Section, & Right Wing (see below).

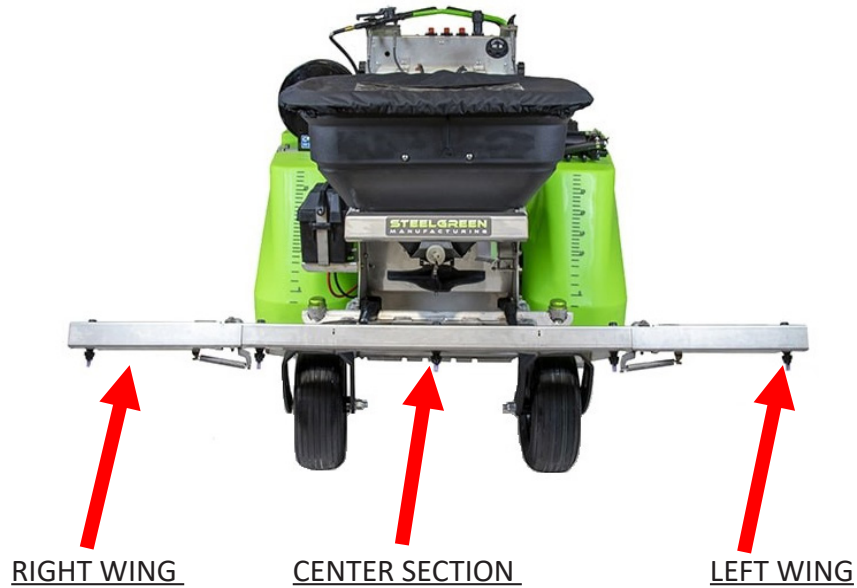

NOTICE

Orientation is from the riders view, standing on the machine (layout is the same for all SG series)

SPRAYER CONTROLS:



Each section of the boom is controlled by a dedicated Lever Valve located on the spray manifold.

- The 3 lever valves can be opened all at once or individually depending on the desired spray width. The middle valve controls the middle boom which holds 3 (SG52) or 2 (SG46, SG42, SG36) nozzles. The left and right valves control the left and right boom wings.
- Each boom wing holds 1 nozzle.
- The lever valve is open in the “UP” position and closed in the “Down” position.

CONTROLS & OPERATION

TIP PART NO. (STRAINER MESH SIZE)	PSI	DROP SIZE	CAPACITY ONE TIP IN GPM	CAPACITY ONE TIP IN OZ/MIN	APPLICATION RATE FOR 20" SPRAY TIP SPACING														
					GALLONS PER ACRE (GPA)				GALLONS PER 1,000 SQ FT										
					4 MPH	5 MPH	6 MPH	8 MPH	3 MPH	4 MPH	5 MPH	6 MPH	7 MPH	8 MPH					
AIC11002 (50)	30	XC	0.17	22	12.6	10.1	8.4	6.3	0.39	0.29	0.23	0.19	0.17	0.14					
	40	XC	0.20	26	14.9	11.9	9.9	7.4	0.45	0.34	0.27	0.23	0.19	0.17					
	50	VC	0.22	28	16.3	13.1	10.9	8.2	0.50	0.37	0.30	0.25	0.21	0.19					
AIC110025 (50)	30	XC	0.22	28	16.3	13.1	10.9	8.2	0.50	0.37	0.30	0.25	0.21	0.19					
	40	XC	0.25	32	18.6	14.9	12.4	9.3	0.57	0.43	0.34	0.28	0.24	0.21					
	50	VC	0.28	36	21	16.6	13.9	10.4	0.63	0.48	0.38	0.32	0.27	0.24					
AIC11003 (50)	30	XC	0.26	33	19.3	15.4	12.9	9.7	0.59	0.44	0.35	0.29	0.25	0.22					
	40	XC	0.30	38	22	17.8	14.9	11.1	0.68	0.51	0.41	0.34	0.29	0.26					
	50	VC	0.34	44	25	20	16.8	12.6	0.77	0.58	0.46	0.39	0.33	0.29					
AIC11004 (50)	30	XC	0.35	45	26	21	17.3	13.0	0.79	0.60	0.48	0.40	0.34	0.30					
	40	XC	0.40	51	30	24	19.8	14.9	0.91	0.68	0.54	0.45	0.39	0.34					
	50	VC	0.45	58	33	27	22	16.7	1.0	0.77	0.61	0.51	0.44	0.38					
AIC11005 (50)	30	XC	0.43	55	32	26	21	16.0	0.97	0.73	0.58	0.49	0.42	0.37					
	40	XC	0.50	64	37	30	25	18.6	1.1	0.85	0.68	0.57	0.49	0.43					
	50	VC	0.56	72	42	33	28	21	1.3	0.95	0.76	0.63	0.54	0.48					
AIC11006 (50)	30	XC	0.52	67	39	31	26	19.3	1.2	0.88	0.71	0.59	0.51	0.44					
	40	XC	0.60	77	45	36	30	22	1.4	1.0	0.82	0.68	0.58	0.51					
	50	VC	0.67	86	50	40	33	25	1.5	1.1	0.91	0.76	0.65	0.57					
AIC11008 (50)	30	XC	0.69	88	51	41	34	26	1.6	1.2	0.94	0.78	0.67	0.59					
	40	XC	0.80	102	59	48	40	30	1.8	1.4	1.1	0.91	0.78	0.68					
	50	XC	0.89	114	66	53	44	33	2.0	1.5	1.2	1.0	0.86	0.76					
HIGH VOLUME SPRAY CHART																			
AIC11010	30	UC	0.87	111	65	52	43	32	2.0	1.5	1.2	0.99	0.85	0.74					
	40	XC	1.00	128	74	59	50	37	2.3	1.7	1.4	1.1	0.97	0.85					
	50	XC	1.12	143	83	67	55	42	2.5	1.9	1.5	1.3	1.1	0.95					
AIC11015	30	UC	1.30	166	97	77	67	48	2.9	2.2	1.8	1.5	1.3	1.1					
	40	XC	1.50	192	111	89	74	56	3.4	2.6	2.0	1.7	1.5	1.3					
	50	XC	1.68	215	125	100	83	62	3.8	2.9	2.3	1.9	1.6	1.4					

NOTE: Always double-check your application rates. Droplet size classification shown is based on ISO 25358. Droplet size classification standard is subject to change. Tabulations are based on spraying water at 70°F.

Mixing of liquid or dry product should be in accordance to manufacturers' labels. This machine is designed for low volume spraying, and the mix will be more concentrated.

This machine is factory set to put down 1/3 gallon of liquid per thousand square feet (at 5 mph and 40 PSI). For instance, some products call for 1.1 to 1.5 ounces per thousand square feet. It is recommended to use 1.3 ounces of product per thousand square feet (median value of 1.1 to 1.5).

If you were filling a 30-gallon tank, your equation would look like:
 (Tank Capacity ÷ Spray Rate) x Chemical Rate = Amount of product in tank
 Example: (30 gal ÷ .34 gal/l k) x 1.3 oz = 114.7 oz

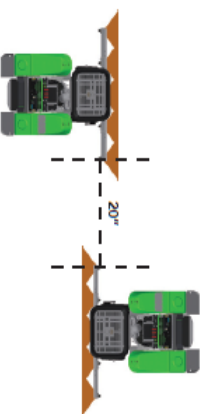

CARE & MAINTENANCE

WARNING

- Do not operate the engine in a confined space where carbon monoxide and other fumes can accumulate.
- Never lubricate, service, or adjust the machine or spreader while it is moving or running.
- Keep hands, feet, clothing, hair, and loose items away from any moving parts.

CAUTION

- Understand service and maintenance procedure before performing any work on this machine or spreader.
- Disconnect the battery before making any repairs.
- Keep all parts in good condition & operating properly.
- Fix damages immediately. Replace all worn or damaged parts.
- Check all hardware at frequent intervals to ensure they are tight.

MAINTENANCE TIPS

- Always avoid letting product sit in the tanks and pump for an extended period of time.
- Blowing off unit is preferred over washing. But if washing unit dry it off as best as possible.
- Refer to engine owner's manual for all other specs.

HOPPER CLEANING:

- Use appropriate footwear, eye protection, and clothing when cleaning the spreader.
- The key to years of trouble-free service is to keep your spreader clean and dry.
- Never allow material to remain in hopper for extended periods of time.
- Empty material from hopper at the end of each day. See page 12 for hopper drain instructions.
- Use a hose or wipe excess material off of the spreader at the end of each day.
- Open and close the gate as you rinse to avoid buildup of material.
- Quickly towel dry the spreader.

WINTERIZATION:

Proper winterization of the spray system helps to prevent damage to the system due to wintertime freezing. Follow these easy steps:

- 1 Drain all of the remaining liquid from the tanks and spray system.
- 2 Fill the tanks with enough RV antifreeze to fill the entire system.
- 3 Turn on the liquid pump and open all boom valves until solution is visible out of spray nozzles. Close boom valves.
- 4 Open valve for hose reel and begin spraying solution thru the nozzle.
- 5 Put the recommended amount of fuel stabilizer and follow the label for instructions.

CARE & MAINTENANCE

SUGGESTED SERVICE	ACTION	DAILY	WEEKLY	BI-WEEKLY	MONTHLY	YEARLY	HOURS	
Front Caster Wheels	Grease				X			
Front Caster Yoke	Grease				X			
Front Tire Pressure	22 PSI		X					
Front Tire Bearing	Preload				X			
Rear Tire Pressure	18 PSI		X					
Rear Lug Nut	Torque 75 lbs.				X			
Rear Hub Castle Nut	Check the cotter pin				X			
Frame Hardware	Check all bolts & fastners				X			
Idler Pulley Arm	Grease				X			
Belt Wear	Cracks,Tears,Missing Material				X			
Hopper Cables	Lubricate w/Silicone spray		X					
Accuway Cable								
Deflector Shield Cable								
Hopper Bottom Bushing	Change if needed				X	Replace		
Hopper Spinner				X				
CLEAN SPINNER DAILY IF NEEDED								
Engine Oil	Check	X						
	Change							
Engine Air Filter	Check/Change if needed		X			Replace	100 Hrs.	
Engine Air Pre-Filter								
Engine Fuel Filter						Replace		
Engine Spark Plugs								
Hydraulic Oil	Change						500 HRS.	
Hydraulic Oil Filter								
Hydraulic Oil Level	Check	X						
Hydro System Fittings	Check for leaks		X					
Chemical Leaks	Check		X					
Spray Nozzle Tips								
Spray Nozzle Tip Screens								
Spray Gun Tip								
Spray Nozzle Gasket								
Spray System Hoses					X			
In-Line Filter					X			
In-Line Filter Gasket					X			
Spray Gun Hose Reel\Coil Hose						X		
SG MACHINES BLOW FERT OFF DAILY								

The suggested maintenance schedule above is recommended for normal use, maintenance will vary for heavier use. SteelGreenMfg. reserves the right to determine usage.

CARE & MAINTENANCE

GREASE POINTS:

There are 5 grease points on a SG machine:

- 1 on each front tire.
- 1 on each of the caster tubes.
- 1 on the idler arm.

IDLER ARM GREASE POINT

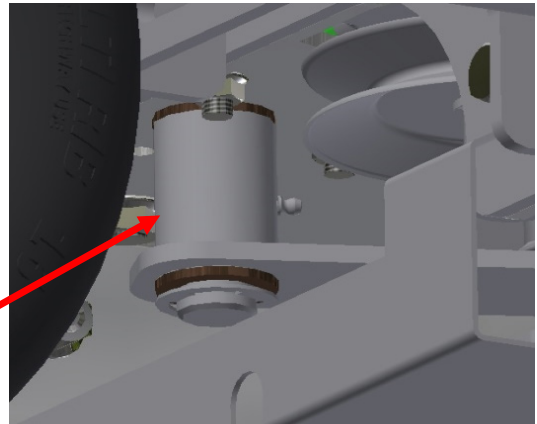

CASTER TUBE GREASE POINT
(BOTH SIDES)

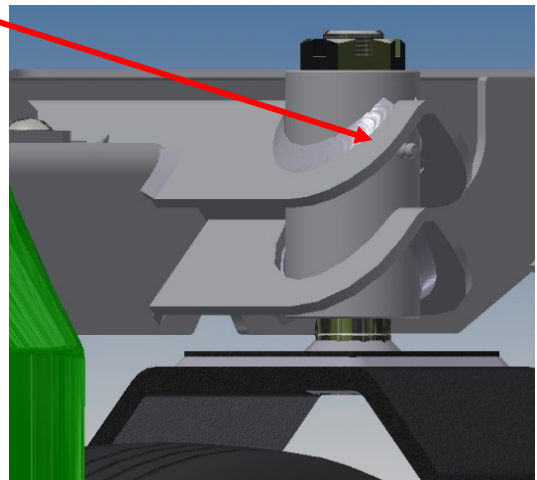

FRONT TIRE GREASE POINT
(BOTH FRONT TIRES)



NEW WHEEL WITH SEALED BEARINGS



CARE & MAINTENANCE

ENGINE OIL CHANGE:

STEP 1: Loosen and remove the engine oil “dip stick”.

NOTICE

Change engine oil & filter every 100 hours with 5w50 full synthetic oil, API service classification SN, Resource conserving; ILSAC GF-5.

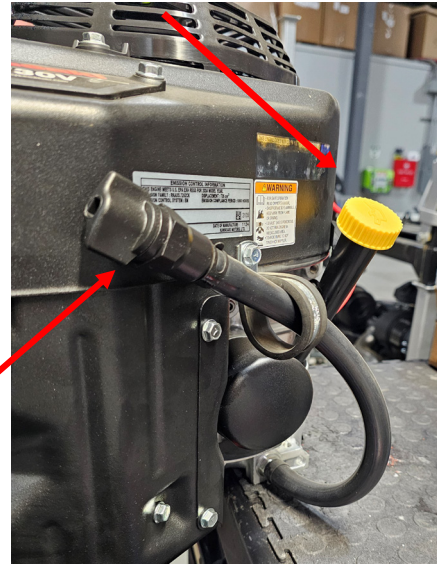

STEP 2:

- Remove the engine oil drain hose from the loop clamp.

NOTICE

For Briggs & Honda engines, remove the drain hose from the clip.

- Place the hose over a proper container, remove the plug to drain the engine oil.
- Once the oil has been drained, reinstall the plug and reattach the hose.



CARE & MAINTENANCE

STEP 3: Remove and replace the engine oil filter.

NOTICE

SG36 unit for easier access to the engine oil filter, remove the left rear tire.

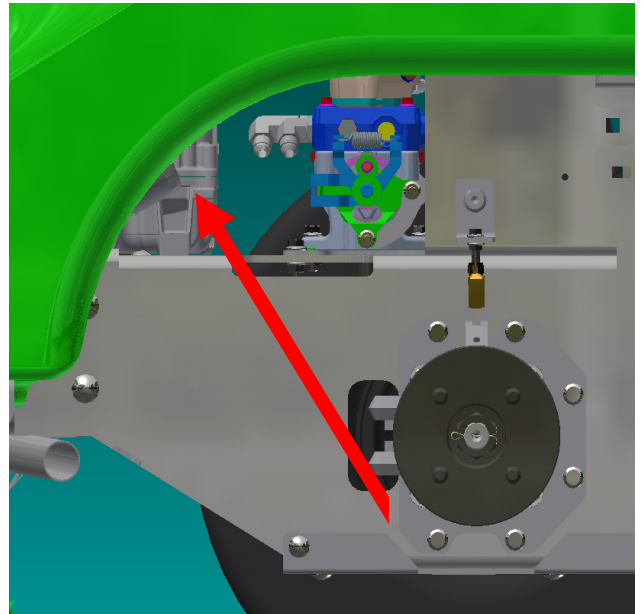
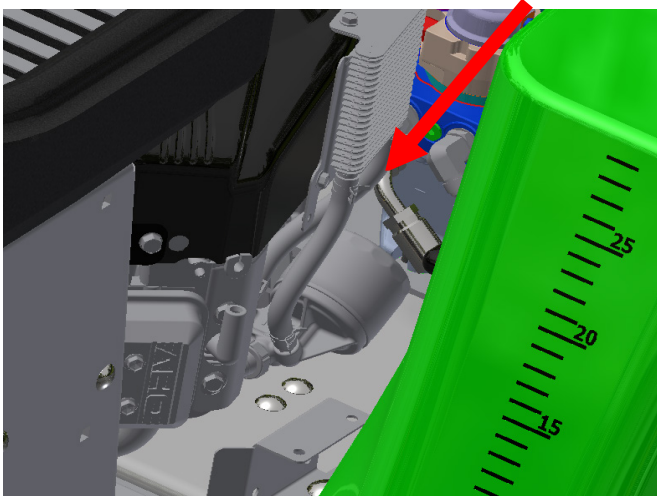

STEP 4: Refill the engine oil to the proper level (1.75Qts. MAX.) with 5w50 full synthetic.

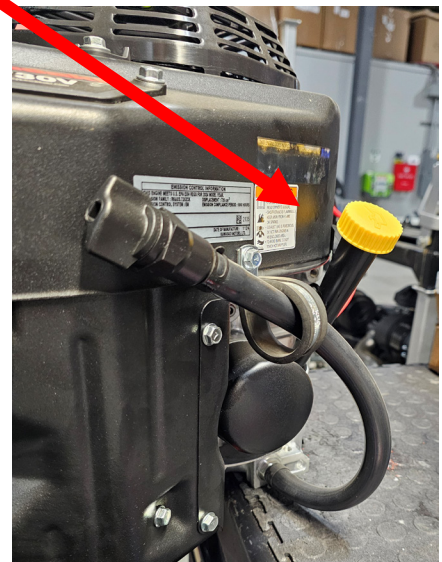

CARE & MAINTENANCE

HYDRAULIC OIL CHANGE:

NOTICE

Change hydraulic oil and filter every 500 hours with 5w50 full synthetic oil. API service classification SN, Resource conserving; ILSAC GF-5.

STEP 1: Remove the knee pad to access the hydraulic oil reservoir.

STEP 2:

- Loosen and remove the cap from the hydraulic oil reservoir.
- Disconnect the rear hoses from the hydraulic pumps, place the hoses over a proper container draining the hydraulic oil.
- Once the oil has been drained, reconnect the hoses to the pumps.

NOTICE

To drain the most oil out as possible, you can also remove the rear tires and disconnect the hoses from the wheel motors to drain the oil at the lowest point.

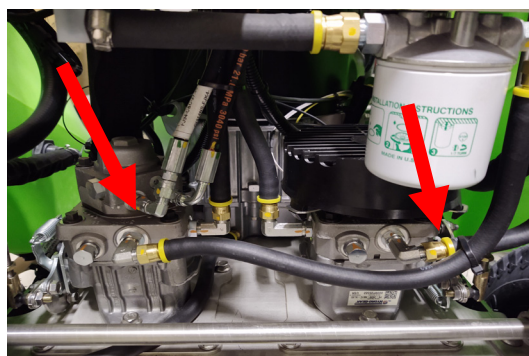
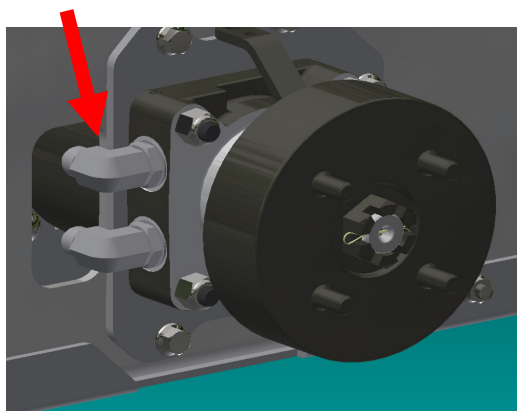
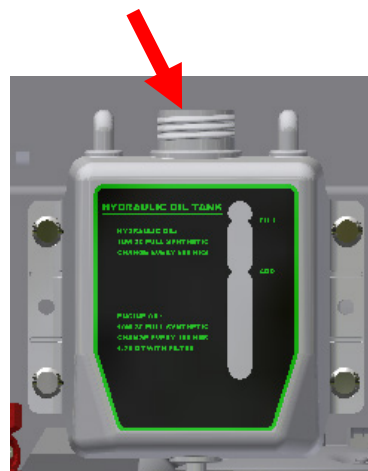
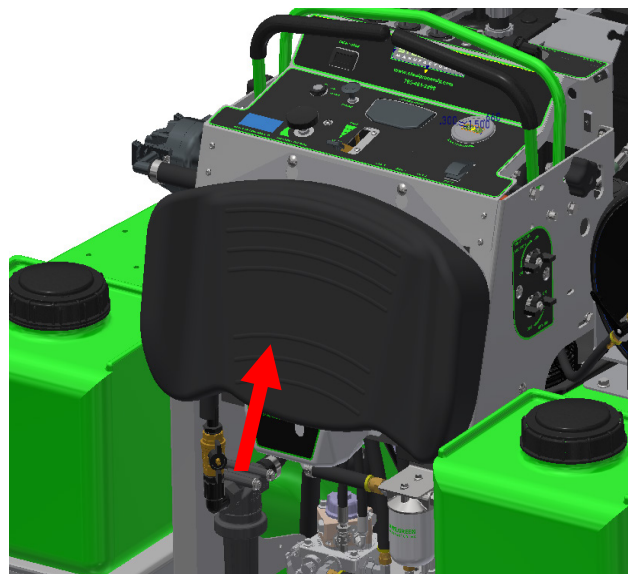

CARE & MAINTENANCE

STEP 3: Remove and replace the hydraulic oil filter.

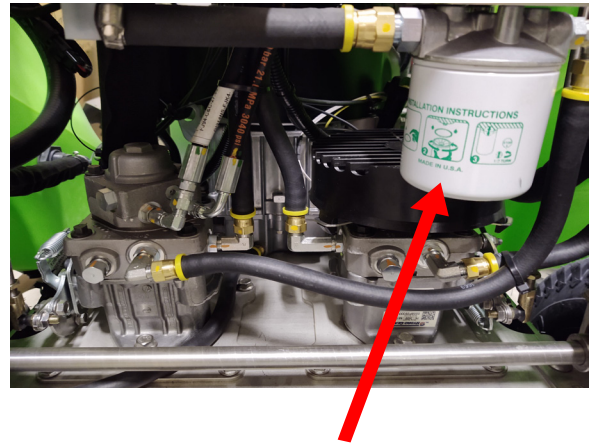

STEP 4:

- Refill the hydraulic oil to the full line. with 5w50 full synthetic.
- Jack up the rear of the machine so the rear tires are off of the ground.
- Start and run the machine in forward and reverse to cycle the hydraulic oil back through the system, you will see the oil level drop in the reservoir.
- Once the oil level has dropped, refill the reservoir to the full line and reinstall the cap.

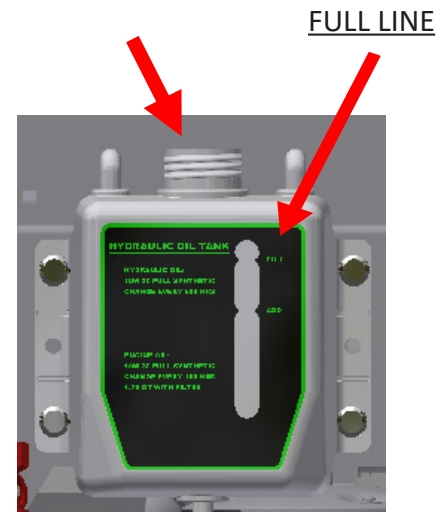

DRAWINGS & DIAGRAMS

DRIVE BELT:

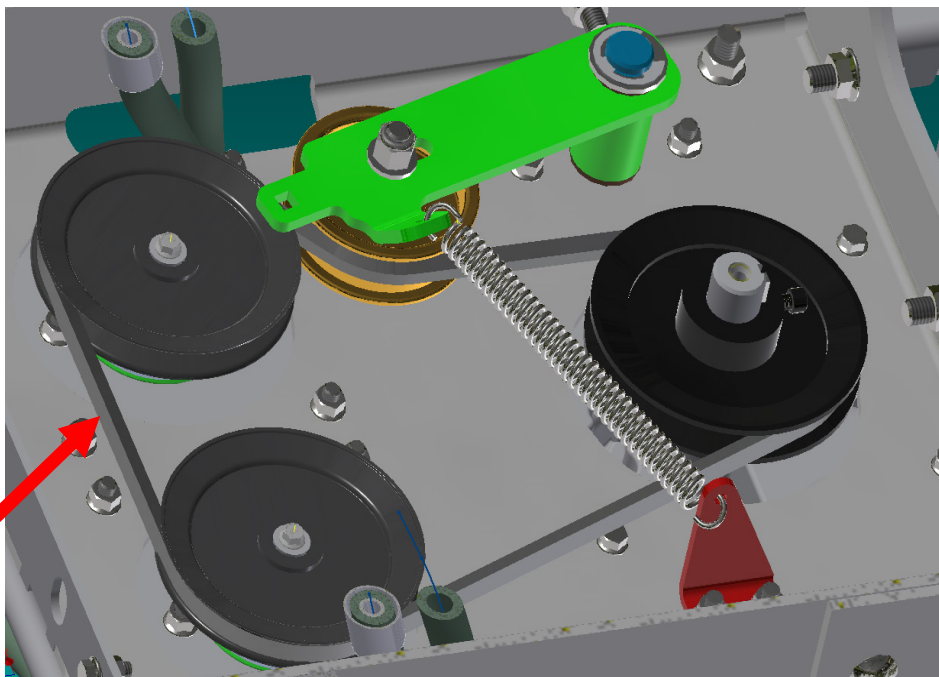

DRIVE BELTS:

A48R SG 36/42

A50R SG 46/52

NOTICE

Please visit steelgreenmfg.com for drive belt replacement instructions & instruction manuals.

DRAWINGS & DIAGRAMS

HYDRAULIC SYSTEM:

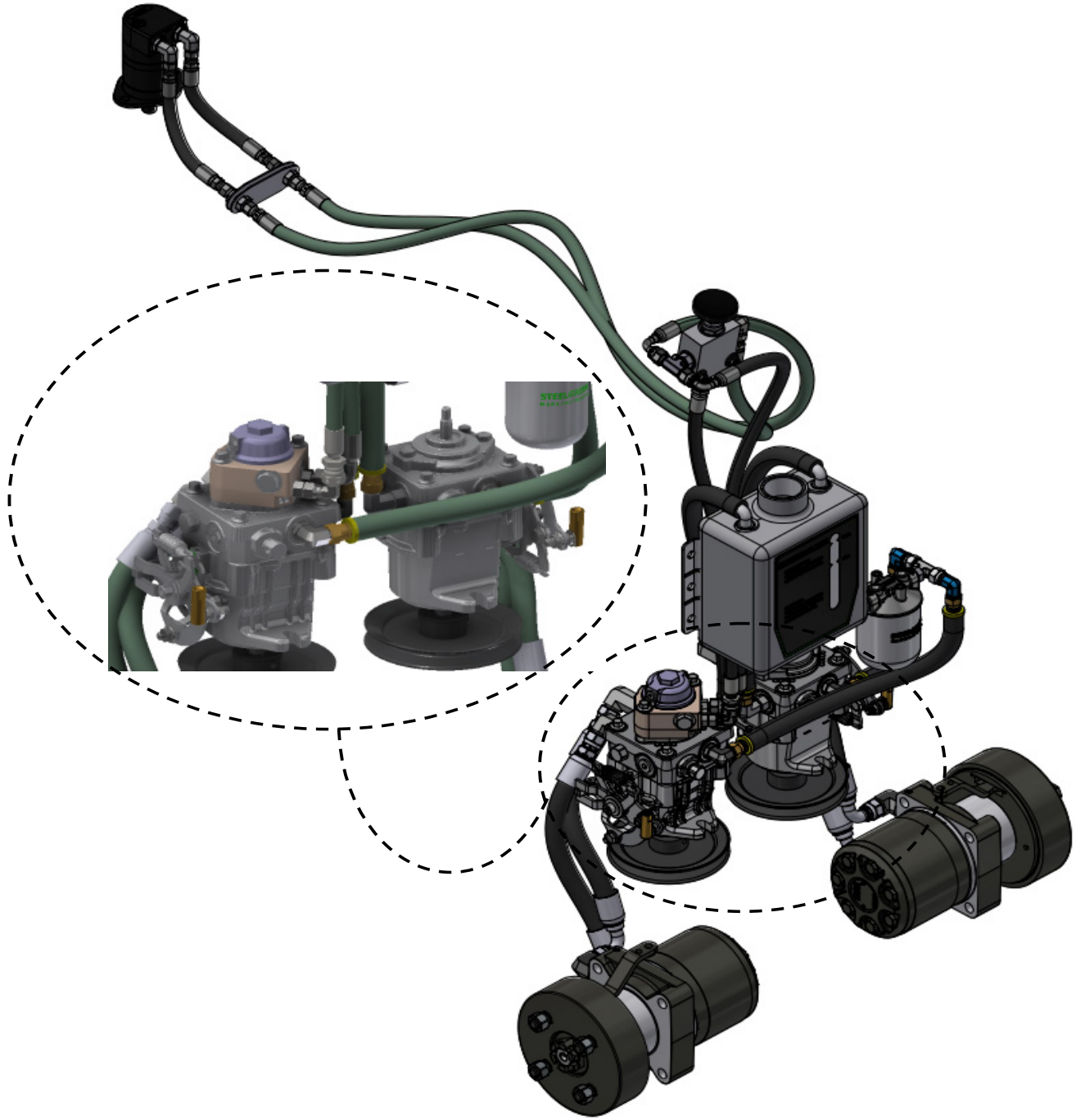

DRAWINGS & DIAGRAMS

STANDARD HYDRAULIC PLUMBING:

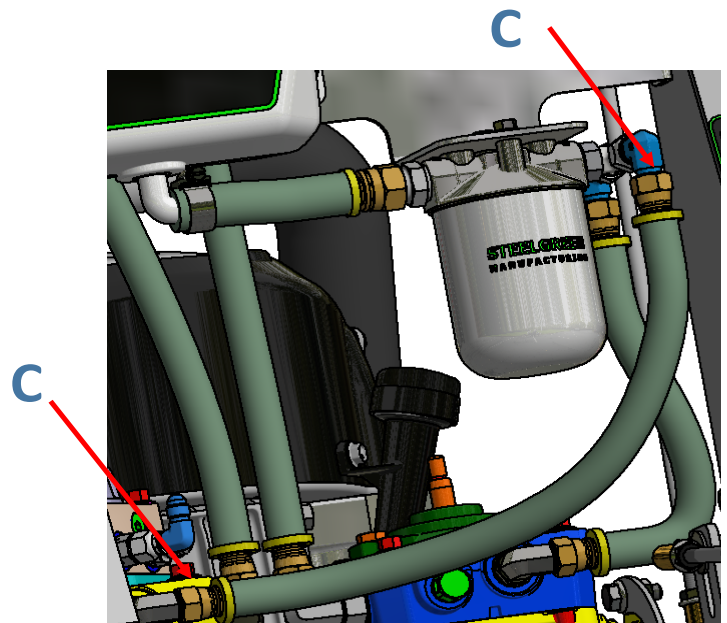
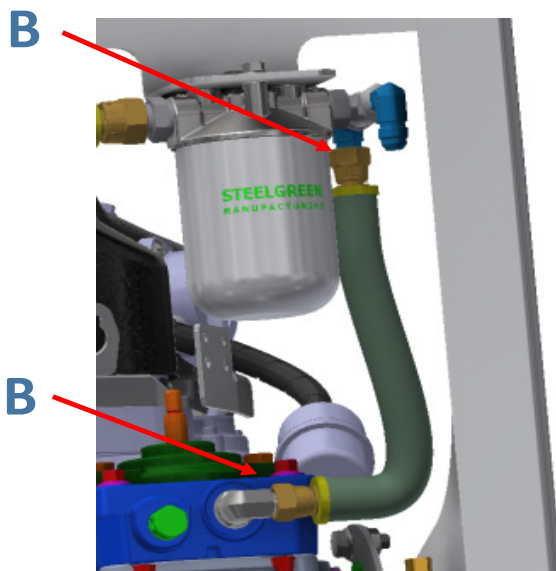
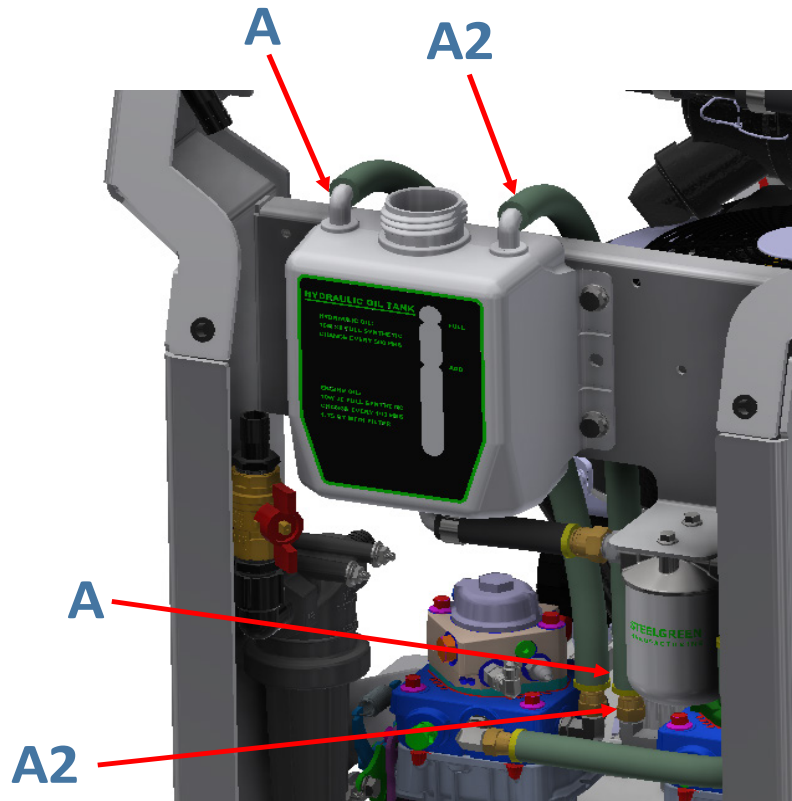

DRAWINGS & DIAGRAMS

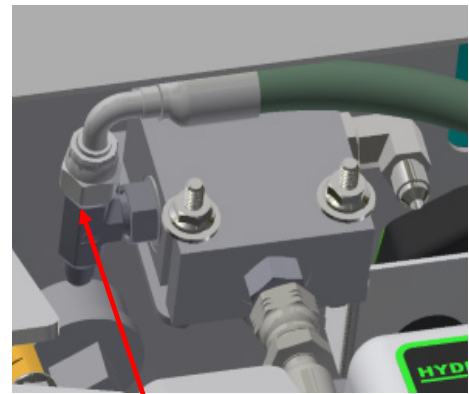
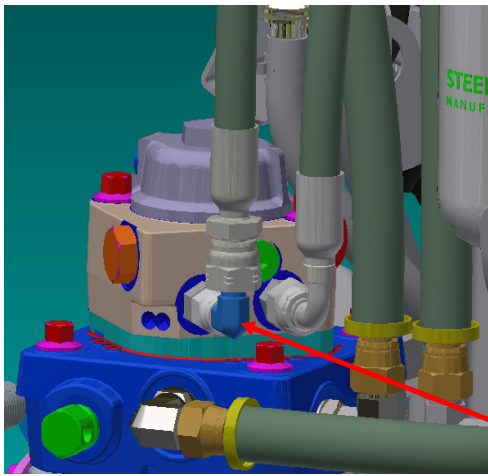
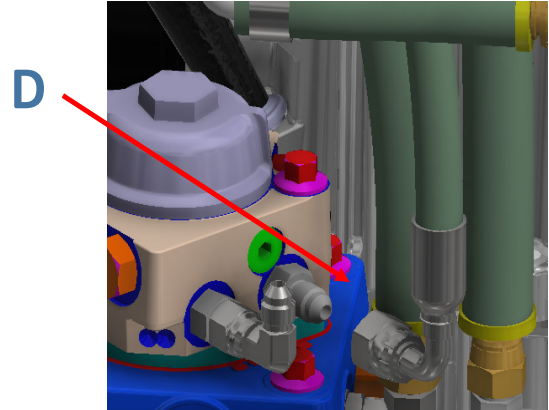
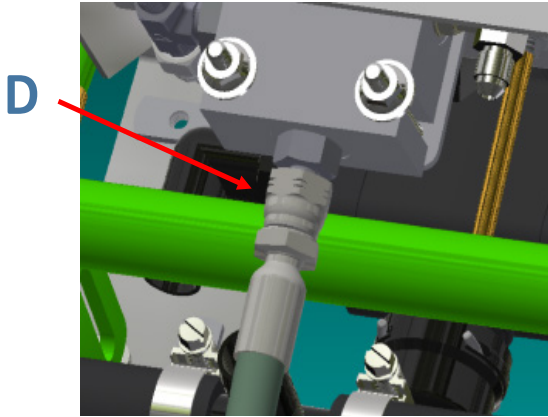

HOPPER HOSE, (STRAIGHT FITTING)

HOPPER HOSE, (ELBOW FITTING)

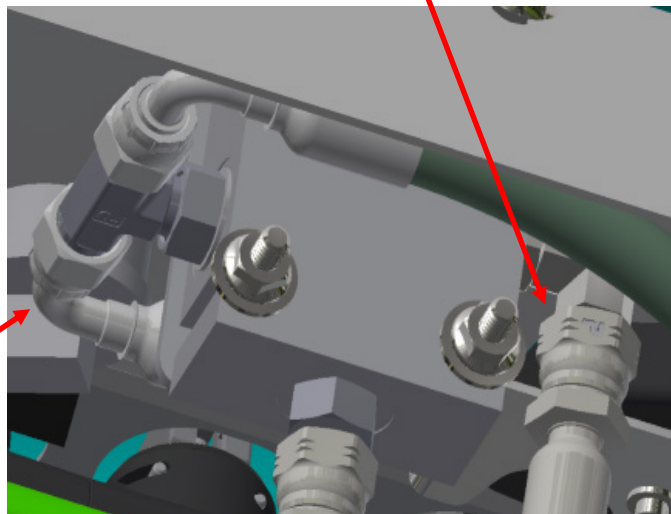

DRAWINGS & DIAGRAMS

STANDARD SPRAY SYSTEM PLUMBING:

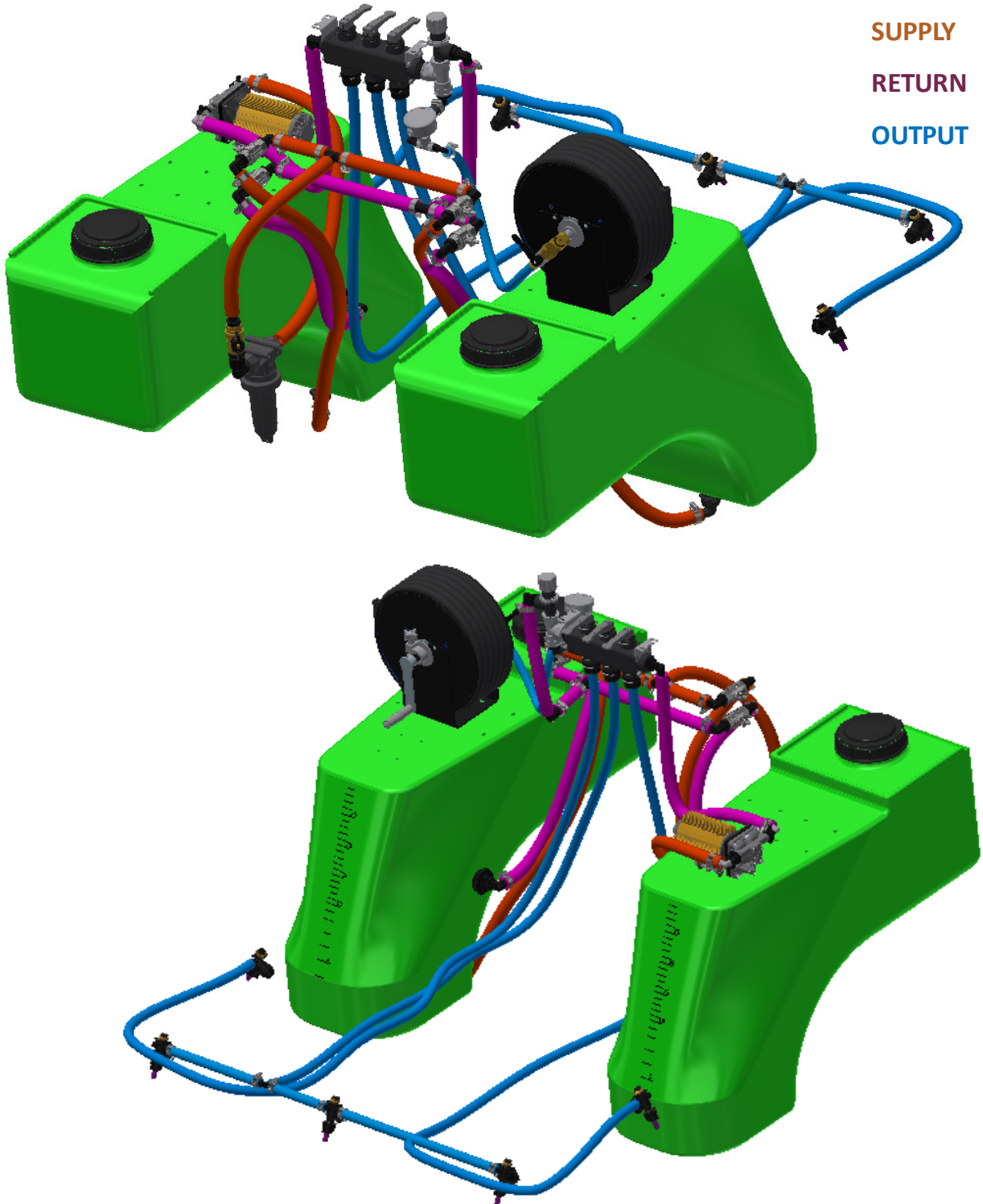



NOTES:



NOTES:



NOTES:



NOTES:



Steel Green Manufacturing, LLC

1-Year Limited Warranty

- A. WHAT IS COVERED** – This Warranty applies to equipment having model numbers SG52, SG46, SG42, and SG36 (“Equipment”) manufactured by Steel Green Manufacturing, LLC, an Indiana limited liability company (“Steel Green”). This Warranty only applies to Equipment purchased directly from Steel Green or an authorized dealer or distributor of the Equipment (“Authorized Dealers”) in the United States. Except for Excluded Parts (as hereinafter defined), Steel Green agrees to repair or replace, at its option, any original component of the Equipment that is defective in material or workmanship (collectively “Warranty Service”). This Warranty begins on the date the product is delivered to the original purchaser and continues for a period of twelve (12) months thereafter (the “Warranty Term”).
- B. WHAT IS NOT COVERED** – This Warranty does not apply to the following categories of equipment: (1) used Equipment, unless there has been an Approved Transfer (as hereinafter defined); or (2) Equipment that has been altered or modified in ways not approved by Steel Green, including, but not limited to, setting injection pump fuel delivery above specifications stated in the owner’s manual. Furthermore, this Warranty does not apply to damage due to any of the following: (1) normal wear and tear; (2) the failure to perform reasonable and proper maintenance; (3) the failure to follow instructions and recommendations in the owner’s manual; (4) negligent or intentional misuse; (5) failure to properly store the Equipment; (6) vandalism; (7) the elements and inclement weather; or (8) collision or accident. “Excluded Parts” means the following parts, which are not covered by and are expressly excluded from this Warranty: (1) consumable parts, such as oil, filters, belts, brakes, and spark plugs; (2) tires; (3) batteries; and (4) the engine. The manufacturers of the Excluded Parts may provide a separate warranty. See manufacturers’ manuals for details.
- C. WHO IS COVERED** – This Warranty extends to the original purchaser of the Equipment who completes and returns the warranty registration card included with the Equipment to Steel Green and to any subsequent owner (collectively “you”), provided the subsequent owner notifies Steel Green of the change in ownership and Steel Green approves the transfer of this Warranty (“Approved Transfer”). An Approved Transfer does not extend the Warranty Term.
- D. HOW IS WARRANTY SERVICE OBTAINED** – To obtain Warranty Service, you must: (1) report the Equipment defect to Steel Green within the Warranty Term; and (2) deliver the Equipment for Warranty Service within a reasonable time thereafter. All Warranty Service must use new or remanufactured parts or components furnished or approved by Steel Green and must be performed by Steel Green, an Authorized Dealer, or a service center approved by Steel Green (“Authorized Service Center”), as directed by Steel Green. This Warranty only covers the costs of parts and labor associated with Warranty Service. You are responsible for delivering the Equipment for Warranty Service, at your sole cost and expense. Steel Green is not responsible for any costs or liability associated with any pickup, delivery, or other transportation required to obtain Warranty Service.
- E. ADDITIONAL LIMITATIONS AND EXCLUSIONS** – Except as expressly provided herein, Steel Green makes no warranties, representations, conditions or promises, express or implied, as to the quality, performance or freedom from defect of the Equipment covered by this Warranty. STEEL GREEN DOES NOT MAKE ANY STATUTORY OR IMPLIED WARRANTIES OR CONDITIONS OF MERCHANTABILITY OR FITNESS FOR A PARTICULAR PURPOSE, AND SUCH WARRANTIES ARE EXPRESSLY DISCLAIMED. TO THE EXTENT THEY ARE LEGALLY REQUIRED, ANY IMPLIED WARRANTIES OR CONDITIONS SHALL BE LIMITED IN DURATION TO THE WARRANTY TERM.



STEEL GREEN'S ONLY LIABILITY WITH RESPECT TO THIS WARRANTY AND YOUR EXCLUSIVE REMEDY SHALL BE FOR THE REPAIR OR REPLACEMENT OF PARTS AS SET FORTH HEREIN. NO CLAIM FOR BREACH OF WARRANTY SHALL ENTITLE YOU TO CANCELLATION OR RESCISSION OF THE PURCHASE OF THE EQUIPMENT.

IN NO EVENT WILL ANY AUTHORIZED DEALER, ANY AUTHORIZED SERVICE CENTER, STEEL GREEN OR ANY COMPANY AFFILIATED WITH STEEL GREEN BE LIABLE FOR INCIDENTAL OR CONSEQUENTIAL DAMAGES. Examples of such damages include, but are not limited to: (1) the loss or damage to person or property other than that covered by this Warranty; (2) attorneys' fees; (3) claims for lost revenue or lost profits; and (4) rental costs of similar equipment to the Equipment.

SOME STATES DO NOT ALLOW THE EXCLUSION OR LIMITATION OF INCIDENTAL OR CONSEQUENTIAL DAMAGES, OR LIMITATIONS ON THE DURATION OF AN IMPLIED WARRANTY, SO THE ABOVE LIMITATIONS AND EXCLUSIONS MAY NOT APPLY TO YOU. THIS WARRANTY GIVES YOU SPECIFIC LEGAL RIGHTS, BUT YOU MAY ALSO HAVE OTHER RIGHTS, WHICH VARY FROM STATE TO STATE.

- F. NO OTHER WARRANTIES** – NO OTHER PERSON OR ENTITY, INCLUDING ANY AUTHORIZED DEALER, HAS AUTHORITY TO MAKE ANY WARRANTY, REPRESENTATION, CONDITION OR PROMISE ON BEHALF OF STEEL GREEN, OR TO MODIFY THE TERMS OR LIMITATIONS OF THIS WARRANTY IN ANY WAY, WHETHER ORALLY OR IN WRITING. STEEL GREEN MAKES NO OTHER WARRANTY RELATED TO THE EQUIPMENT OR ANY OTHER ITEM UNLESS IT DELIVERS TO YOU A SEPARATE WRITTEN WARRANTY.
- G. CONTACT** – To obtain a replacement warranty registration card or report a defect in any Equipment, to find the nearest Authorized Dealer or Authorized Service Center or report your dissatisfaction with their assistance, or to otherwise obtain information regarding this Warranty, please contact Steel Green.

Steel Green Manufacturing LLC
Attn: Customer Service
824 S State Road 39
Lebanon, Indiana 46025
(765) 481-2890
sales@steelgreenmfg.com
Steelgreenmfg.com



WARRANTY REGISTRATION FORM

Fill out form completely and return to **Steel Green Manufacturing**
Email: sales@steelgreenmfg.com
Mail: 824 S State Road 39, Lebanon, IN 46052



CONTACT INFORMATION

Company Name: _____
 Contact Name: _____
 Street: _____
 City: _____ State: _____ ZIP Code: _____
 Phone: _____ Email: _____

MACHINE INFORMATION

Serial Number: _____ Date of Purchase: _____
 Dealer Name: _____
 Street: _____
 City: _____ State: _____ ZIP Code: _____
 Phone: _____ Salesperson: _____



steelgreenmfg.com (765) 481-2890    @SteelGreenMFG

